



Andrew Haslam

In conjunction with

legal*i* insider

eDisclosure Systems – Buyers Guide

2019 Edition

Always check the Buyer's Guide section of the Legal IT Insider website to make sure you have the latest version of this document.

Check [here](#).

Document Reference :
eDisclosure Systems - Buyers Guide 2019 V7_0.docx

Issue : 7.0

Dated 23 Apr 2019

COPYRIGHT AND CONFIDENTIALITY

First published in February 2013 by Allvision Computing.

With the exceptions shown below, Andrew Haslam owns the copyright and other intellectual property rights in the content of the Guide. You are permitted to print and download any part of the Guide for your own use and/or for other third parties use, free of charge, provided that: the content of the Guide is not modified in any way; our copyright notice is retained on all copies; you acknowledge Andrew Haslam, and it appears on as the source of the Guide; and you inform third parties that the terms of this copyright notice and the disclaimer contained in the Guide apply to them and that they must comply with it.

All rights are otherwise reserved. For the avoidance of doubt you are not permitted to incorporate the Guide or any part of it in any other work or publication, whether in hard copy, electronic, or any other form, without the prior written permission of Andrew Haslam except as permitted by law.

Applications for written permission should be sent by email to

andrew.haslam@allvision.co.uk

Full acknowledgement of the authors and source must be given.

Andrew Haslam reserves the right to modify the terms of this copyright notice at any time.

The copyright of all material in Chapter 8 remains with the respective suppliers.

The copyright of the cartoons in Chapters 3 and 5 remains with the respective authors/organisations. If you enjoy the "Queen's Counsel" strips you can buy a book of them [here](#).

© Andrew Haslam 2019

DISCLAIMER

This Buying Guide is intended merely as a guide or review for readers when considering what products or services they may be interested in purchasing. Andrew Haslam does not make, and nothing in this Buying Guide is intended to constitute, any warranties, guarantees, representations or assurances about the accuracy of the information or content contained in this Buying Guide. Furthermore, Andrew Haslam does not make, and nothing in this Buying Guide is intended to constitute, any warranties, guarantees, representations or assurances about the nature or performance of the products or services appearing in the Buying Guide. Andrew Haslam is not affiliated with nor does he endorse the use of any particular product or service.

Any opinions expressed in this Guide are those of Andrew Haslam and do not reflect the opinions or policies of Squire Patton Boggs.

TRADEMARKS / LOGOS

All Trademarks and Logos are the sole property of their organisations and their use here does not imply auditing or endorsement by any organisation or any of their member firms.

COMMENTS ON PREVIOUS EDITIONS

Litigation Support Managers

"This is amazing and I know it will become the "must have bible" for the industry."

"This looks really useful – I have been under pressure to produce something along these lines myself."

"This looks really interesting and useful... I do think it will be a very useful resource."

"I like your initiative and is something which I know would be of industry wide interest..."

"I've printed the Guide out in A5 format and I carry it with me wherever I go, it's so useful."

Suppliers

"The more I have an opportunity to study your report – the more I am impressed with the breadth and depth of the content. Thanks again for sharing the report. This is an excellent tool I have already shared with the executive team at...."

"Congratulations on compiling this. It looks like it was quite an undertaking – but the result is great document."

"I have just got back from holiday and saw the publication – excellent work."

"What Andrew has put together is nothing short of remarkable and IMO puts Gartner to shame."

"I have to tell you that I'm deeply impressed by the Buyer's Guide you have put together! I'm working now for about 7 years in the eDiscovery/Forensics field and I couldn't agree more with what you have written. I will put your document on the mandatory reading list for our new joiners."

"I joined the eDisclosure industry 3 months ago with no knowledge of the subject, your Buyer's Guide has been the single most useful document I have found to educate myself. Thank you."

FOREWORD (2019)

Welcome to the seventh edition of the Buyer's Guide to eDisclosure Systems. By the time this document is published, we will be several months into the two year pilot of the changes to the [Civil Procedure Rules](#) for eDisclosure, with their emphasis on increased use of technology. It is hoped that this Guide will assist people in the assessment and selection of suitable technology, as the marketplace continues to consolidate, and also offers new entrants with associated newer functionality.

The eDisclosure Pilot has at its heart the Disclosure Review Document (DRD), which details the various steps and requirements users need to meet, including requiring parties to agree how they will transfer information between them in the disclosure process. During 2018/19, the author was part of a working group from the UK ILTA Special Interest Group for Litigation Support, that has produced a free to use "best practice" exchange protocol, along with accompanying guidelines. You can download the documents from the ILTA site [here](#).

Foreword to Edition 6 (2018)

Welcome to the sixth edition of the Buyer's Guide to eDisclosure Systems. 2018 starts with a pilot of proposed changes to the Civil Procedure Rules for eDisclosure. Those changes have an emphasis on the informed use of technology to support the collection, processing and review of electronic information. It is hoped this publication will assist practitioners in making those informed decisions.

The eDisclosure marketplace continues to consolidate as companies merge, and we are starting to see a slow but steady increase in the number of law firms investing in managed services partnerships with selected suppliers. If you are starting on that journey, or just "dipping your toes" into the world of eDisclosure, this Guide will help you along the way.

Foreword to Edition 5 (2017)

Welcome to the fifth edition of the Buyer's Guide to eDisclosure Systems. 2016 saw continued change in both the UK eDisclosure and the wider world of eDiscovery. The composition of this edition is markedly different to the first volume produced back at the start of 2013.

Last year also saw many momentous changes outside of the insular world of eDisclosure suppliers, one of them being in the employment status of the Author. During 2016 Andrew hung up his consultancy boots, bought his own watch, and took on a permanent role as the UK eDisclosure Project Manager at Squire Patton Boggs LLP. Squire Patton Boggs have agreed that Andrew can continue to produce the Guide, with the clear understanding that it is a personal undertaking and is not endorsed by them in any way.

Foreword to Edition 4 (2016)

Welcome to edition 4 of the Buyer's Guide to eDisclosure Systems, a document that gets bigger (and hopefully better) each year.

The 2015 theme for the UK eDisclosure marketplace has been one of consolidation, with a number of firms being acquired throughout the year, see inside for all the details of who is still around and what they are now called.

During 2015, Andrew was asked to participate in the development of an eDisclosure/Discovery competency standard for the LTC4 consortium, which was formally launched at this year's LegalTech. You can find out more details about the LTC4 initiative and how you can use the standard [here](#).

This version incorporates all the additional and modified vendor information that has been gathered over the past 12 months and welcomes 13 new suppliers to the fold,

balanced by 11 who have left / been acquired as well as 2 name changes. We now have companies from 9 countries in the Guide.

Foreword to Edition 3 (2015)

Welcome to edition 3 of the Buyer's Guide to litigation support systems. The previous version was downloaded some 1,800 times over the year, hopefully this one will be as successful.

This version incorporates all the additional and modified vendor information that has been gathered over the past 12 months and welcomes 27 new suppliers to the fold.

Foreword to Edition 2 (2014)

The first edition of this "bible" was enthusiastically received around the litigation support community, with plaudits being offered from across the world. As a result of that document, in the first half of 2013, the Author was asked to join a working party tasked with providing a "Jackson Compliant" protocol for use within the Technology and Construction Court (TCC). The outputs from that effort can be found [here](#).

As a by-product of the work done for the TCC protocol, the initial chapters to the Guide have been reworked to make them even more of an introduction to eDisclosure in general, and the requirements upon lawyers in particular. It is hoped they prove of use to readers.

Document Authorisation and Version Control

DOCUMENT AUTHORISATION AND VERSION CONTROL

DOCUMENT TITLE	eDisclosure Systems – Buyers Guide 2019
----------------	---

REFERENCE	ISSUE	DATE
Buyer's Guide	Issue 7.0	Apr 19

	NAME	SIGNATURE	DATE
Author	Andrew Haslam		23/04/19

Date	Version	Comment
07/12/12	1.0	Initial draft, prepared for first round of review
25/02/13	1.1	Updated with feedback, copy published on website on 14 March 2013.
28/03/13	1.2	Minor typographical edits, updates to some vendor entries and inclusion of new suppliers and their technology. Copy published on website in April 2013.
26/02/14	2.0	2014 edition, includes all vendor feedback since version 1.2. Text updated to show review of LegalTech 2014, and impact of Jackson changes. Major changes to introductory chapters reflecting input from TCC protocol working party. Copy passed to publisher and placed on website in February 2014.
28/02/15	3.0	2015 edition, includes all vendor feedback since version 2.0. Text updated to show review of LegalTech 2015. Shows results of CAR survey. Copy passed to publisher and placed on website in March 2015
31/03/15	3.1	Minor updates to suppliers details. Copy passed to publisher and placed on website in April 2015.
29/02/16	4.0	2016 edition, includes all vendor feedback since version 3.1. Text updated to show review of LegalTech 2016. Copy passed to publisher and placed on website in March 2016.
31/03/16	4.1	Minor updates to suppliers details. Copy passed to publisher and placed on website in April 2016.
18/04/17	5.0	2017 edition, includes all vendor feedback since version 4.1. Text updated to show review of LegalTech 2017. Removal of annexes on training and CAR survey. Copy passed to publisher and placed on website in April 2017.
31/05/17	5.1	Minor updates to supplier details. Copy passed to publisher and placed on website in June 2017.
29/03/18	6.0	2018 edition, includes all vendor feedback since version 5.1. Text updated to show review of LegalTech 2018. Copy passed to publisher and placed on website in April 2018.
18/05/18	6.1	Minor updates. Copy passed to publisher and placed on website in May 2018.
xx/04/19	7.0	2019 edition, includes all vendor feedback since version 6.1. Copy passed to publisher and placed on website in April 2018.

Contents

CONTENTS

1.	EXECUTIVE SUMMARY	1
2.	GUIDE STRUCTURE	2
3.	eDisclosure – An Introduction	7
3.1	Definition	7
3.2	EDRM Model	8
3.2.1	Description	9
3.2.2	Legal Implications	9
3.2.3	Who can help	9
3.3	Information Governance	9
3.3.1	Description	9
3.3.2	Legal Implications	9
3.3.3	Who can help	9
3.4	Identification	9
3.4.1	Description	9
3.4.2	Legal Implications	9
3.4.3	Who can help	10
3.5	Preservation	10
3.5.1	Description	10
3.5.2	Legal Implications	10
3.5.3	Who can help	10
3.6	Collection	11
3.6.1	Description	11
3.6.2	Legal Implications	11
3.6.3	Who can help	11
3.7	Processing	12
3.7.1	Description	12
3.7.2	Legal Implications	12
3.7.3	Who can help	12
3.8	Review	13
3.8.1	Description	13
3.8.2	Legal Implications	13
3.8.3	Who can help	13
3.9	Analysis	14
3.9.1	Description	14
3.9.2	Legal Implications	14
3.9.3	Who can help	15
3.10	Production	15
3.10.1	Description	15
3.10.2	Legal Implications	15
3.10.3	Who can help	15
3.11	Presentation	16
3.11.1	Description	16
3.11.2	Legal Implications	16
3.11.3	Who can help	16
3.12	EDRM Summary	16
3.13	CARRM Model	16
3.13.1	EDRM's Computer Assisted Review Reference Model	17
3.13.2	Set Goals	17
3.13.3	Set Protocol	17
3.13.4	Educate Reviewer	17
3.13.5	Code Documents	18
3.13.6	Predict Results	18
3.13.7	Test Results	18

Contents

	3.13.8 Evaluate Results	18
	3.13.9 Achieve Goals	18
	3.13.10 CAR is evolving	18
	3.14 Cooperation in England and Wales	18
	3.15 Overall Summary	19
4.	Technology Areas	20
4.1	Litigation Readiness / RIM / Email Archiving	20
4.1.1	Litigation Readiness	20
4.1.2	RIM / Document Retention Policy/GDPR	20
4.1.3	Email Archiving	21
4.2	Collection – Forensic & Generic	21
4.3	Scanning	21
4.4	Objective & Subjective Coding	22
4.5	Litigation Support Tools	23
4.5.1	Early Case/Data Assessment	23
4.5.2	Litigation Support Systems	23
4.5.3	Multi-Purpose Tools	23
4.6	Presentation Systems	24
5.	Market Survey	25
5.1	Changing Legal Environment	25
5.2	Market review	26
5.2.1	Historical Market Review - Overall	26
5.2.2	Historical Market Review – Litigation Support Products	28
5.2.3	Historical Market Review – ECA Products	28
5.2.4	Historical Market Review – Predictive Coding Products	29
5.3	Vendor Analysis	30
5.3.1	Background / Gartner Report	30
5.3.2	Consultancy Firms	30
5.3.3	Software Specific Organisations	31
5.3.4	Solutions/Bureau Organisations	31
5.3.5	Outsourcing Organisations	31
5.3.6	External Review Teams	32
5.3.7	Managed Review Facilities/Teams	32
5.4	Current Issues / "What's Hot"	33
5.4.1	Clustering	33
5.4.2	Email Threading	33
5.4.3	Automatic Translation	33
5.4.4	Audio / Video Files	33
5.4.5	Computer/Technology Assisted Review	34
5.4.6	Collection of data from Social Media environments	35
5.4.7	Small Quantities of ESI	35
5.4.8	Charging Model	35
5.4.9	Redaction tools for "Native" Formats	35
5.4.10	Email family groups with non-relevant children	36
5.5	Potential Problems	37
5.5.1	Email Groups	37
5.5.2	Re-unitisation of Images of Paper Documents	37
5.5.3	High level allocation of alias for Names Normalisation	37
5.5.4	Data Collection by Client or Law Firm's IT Department	38
5.5.5	Issues of working in "Native" formats	38
5.6	Vendor list	40
5.7	Software list	41
5.7.1	Software – By Supplier	42
5.7.2	Software – By EDRM Function	44
5.8	Relativity "Plugins"	45

Contents

6.	Procurement Approach	48
6.1	Supplier's Pricing / Client Tactics	48
6.1.1	Involve the supplier as soon as possible	48
6.1.2	Tell them as much as possible about the case	48
6.1.3	Understand the supplier's constraints	49
6.1.4	Don't keep asking for the "best of three" quotes	49
6.1.5	Ask for flexibility in pricing	49
6.1.6	Be prepared to do some work in comparing pricing	50
6.2	Overall Requirement/Approach	50
6.2.1	Requirements scoping	50
6.2.2	Match potential vendors to requirement	51
6.2.3	Assess vendor capability	51
6.2.4	Short list	51
6.2.5	Demonstration with real data	51
6.2.6	Establish call off contracts	52
6.3	Scanning	52
6.3.1	Overall Considerations	52
6.3.2	Example Requirements	52
6.3.3	Possible Quotation Format	53
6.4	Unitisation and Coding Services	55
6.4.1	Overall Considerations	55
6.4.2	Example Requirements	55
6.5	Data Collection	56
6.5.1	Overall Considerations	56
6.5.2	Example Requirements	56
6.6	Litigation Support Services	57
6.6.1	Overall Considerations	57
6.6.2	Example Requirements	57
6.7	Processing small volumes of ESI	58
6.7.1	Overall Considerations	58
6.7.2	Example Requirements	58
6.8	Schematic of Generic Requirements	60
6.9	Summary	61
7.	Additional Resources	62
7.1	Legal IT Insider	62
7.2	The e-Disclosure Information Project	62
7.3	The BONG! Emails (Jonathan Maas)	62
7.4	Clive Freedman (eDisclosure web site)	62
7.5	Civil Evidence for Practitioners	62
7.6	Electronic Disclosure – Law and Practice	62
7.7	The 2018 eDiscovery Buyers Guide (US Focus)	63
7.8	The TCC eDisclosure Protocol	63
7.9	The ILTA eDisclosure data exchange Protocol	63
7.10	The TCC Legal/EDRM Timeline	64
8.	Supplier & Software Details	66
8.1	Suppliers	66
8.1.1	7Safe, a PA Group Company	67
8.1.2	AccessData (US)	70
8.1.3	AlixPartners	72
8.1.4	Altlaw	74
8.1.5	Alvarez & Marsal	78
8.1.6	Anexsys	80
8.1.7	Ankura	82
8.1.8	Aon's Cyber Solutions (formerly Stroz Friedberg)	85
8.1.9	ayfie Group AS	88

Contents

8.1.10	BCL Legal	89
8.1.12	BDO LLP	90
8.1.13	blu Eye GmbH (A blu Group company)	93
8.1.14	Brainspace	96
8.1.15	Bundledocs (Ireland)	97
8.1.16	Casepoint (US)	98
8.1.17	Causasoft LLC (Switzerland)	100
8.1.18	Cellebrite	101
8.1.19	Cenza Technologies	102
8.1.20	CloudNine (US)	103
8.1.21	Codex Global	108
8.1.22	Consilio	109
8.1.23	Control Risks	111
8.1.24	Critical Data Services	114
8.1.25	CYFOR	115
8.1.26	Data Analysis Services (DAS)	119
8.1.27	Deloitte LLP	120
8.1.28	DISCO (CS Disco, Inc)	122
8.1.29	EDRM	123
8.1.30	edt	126
8.1.31	eMag Solutions	127
8.1.32	Epiq Systems	128
8.1.33	Ernst & Young	132
8.1.34	Everlaw	134
8.1.35	Exigent Group Limited	135
8.1.36	Exterro UK Limited	139
8.1.37	FRP Advisory	140
8.1.38	FTI Technology (A practice of FTI Consulting)	141
8.1.39	Grant Thornton UK LLP	144
8.1.41	HaystackID (US)	147
8.1.42	Heureka Software, LLC (US)	149
8.1.43	Hillogic (Australia / UK)	150
8.1.44	IBM United Kingdom Limited	151
8.1.45	Iconic Translation Machines	152
8.1.46	i-Lit Limited & i-Lit Paralegals Ltd	154
8.1.47	Innovative Development LLC (IDLLC UK Ltd) LLC	155
8.1.48	Integreon	156
8.1.49	Intelligent Voice	158
8.1.50	Inventus	161
8.1.51	IT Group UK Ltd (Part of Blackrock Expert Services)	163
8.1.52	JND eDiscovery (US)	166
8.1.53	KNOVOS (Capital Novus)	170
8.1.54	KPMG LLP	171
8.1.55	KLDiscovery UK	173
8.1.57	LDM Global	175
8.1.58	Legastat	177
8.1.59	Lighthouse	179
8.1.60	LINEAL	180
8.1.61	LitSavant Ltd	183
8.1.62	London Legal Discovery	184
8.1.63	Maas Consulting Group	186
8.1.64	MedBrief	188
8.1.65	Media Discovery	189
8.1.66	Media Resources	190
8.1.67	Millnet Document Services	191

Contents

8.1.68	Milyli (US)	193
8.1.69	Morae Global	195
8.1.70	Netmaster Solutions Ltd / CaseLines	198
8.1.71	NightOwl Discovery (Ireland)	200
8.1.72	Nuix Technology Ltd	202
8.1.73	Omnis	204
8.1.74	OpenText Discovery	205
8.1.75	Opus 2 International	207
8.1.76	Planet Data Solutions (US)	208
8.1.77	PwC LLP	209
8.1.78	QuisLex	211
8.1.79	Relativity	213
8.1.80	Reveal Data Corporation (Ireland)	214
8.1.82	Ricoh (US)	215
8.1.83	Servient	217
8.1.84	Sky Discovery	219
8.1.85	Smith & Williamson LLP	221
8.1.86	Special Counsel	223
8.1.87	Swiss FTS (Switzerland)	225
8.1.88	SFTS Engineering (Switzerland)	227
8.1.89	The Oliver Group	228
8.1.90	TransPerfect Legal Solutions	229
8.1.91	TSD Services Ltd (Bulgaria)	232
8.1.92	Venio (US)	234
8.1.93	Veritas	235
8.1.94	Vound Software (Intella) (US)	237
8.1.95	XBundle Ltd	238
8.1.96	Yerra Solutions - an Elevate Business (Switzerland)	239
8.1.97	ZyLAB UK Ltd (Dutch)	241
8.1.98	Zylpha	243
8.2	Software	244
8.2.1	AccessData Software Suite	245
8.2.2	Anexsys Review Tool Kit (RTK) Suite	246
8.2.3	Aon Software Suite	249
8.2.4	ayfie Software Suite	250
8.2.5	Bundledocs	252
8.2.6	CaseLines (from Netmaster Solutions)	253
8.2.7	Case Logistix	255
8.2.8	CasePoint	256
8.2.9	Catalyst	258
8.2.10	CloudNine	260
8.2.11	Concordance FYI	263
8.2.12	Consilio Product Suite (Global RPM®)	264
8.2.13	Digital Reef (A TransPerfect Company)	266
8.2.14	DISCO Software	270
8.2.15	DocBuster	274
8.2.17	edt Toolbox	275
8.2.18	Enterprise Vault	281
8.2.19	Enterprise Vault.cloud	282
8.2.20	Epiq Software (DMX and TMX)	283
8.2.21	Equivio Relevance	286
8.2.22	Everlaw	289
8.2.23	Exego (Planet Data Software)	293
8.2.24	ExhibitManager	294
8.2.25	Exterro Software Suite	298

Contents

8.2.26	eZSuite (KNOVOS)	299
8.2.27	FRA Software Suite	300
8.2.29	In Control (Reveal Data Systems)	306
8.2.30	Index Engines	308
8.2.31	Integreon Tools	309
8.2.32	Intella Suite (Vound Software)	311
8.2.33	Intelligent Voice®	318
8.2.34	Inventus software suite	324
8.2.36	KLDiscovery Software Suite	325
8.2.37	KOFAX Capture	331
8.2.38	Law PreDiscovery	332
8.2.39	Lighthouse Technology Solutions	333
8.2.40	LitSavant Conformity Engine	334
8.2.41	LegalCraft® Transcend	337
8.2.42	Magnum	338
8.2.43	MedBrief	339
8.2.44	Millnet DocBuster	340
8.2.45	Milyli Relativity product suite	341
8.2.46	Mindseye TunnelVision	359
8.2.47	MM/PC	360
8.2.48	Morae Software Suite	361
8.2.49	Nexidia	363
8.2.50	NightOwl Discovery Software Suite	365
8.2.51	Nuix (Including Nuix Ringtail)	369
8.2.52	OpenText Discovery Suite (Encase & Axcelerate)	376
8.2.53	Relativity	380
8.2.54	Reveal Software	383
8.2.55	Servient	384
8.2.56	Sightline (From Consilio)	389
8.2.57	SPEKTOR Suite	390
8.2.58	StoredIQ for Legal (IBM)	392
8.2.60	TransCEND (a TransPerfect Legal Solutions Company)	398
8.2.61	TSD Relativity Product Suite	400
8.2.62	UFED Series	404
8.2.63	Venio	406
8.2.64	Veritas	412
8.2.65	Viewpoint	416
8.2.66	XBundle Software	421
8.2.67	ZyLAB Systems	423
8.2.68	Zylpha Solutions	427
	ANNEX A - TECHNICAL GLOSSARY	428
	ANNEX B – Blank Vendor Form	435
	Vendor Information	435
	Software Information	435

1. EXECUTIVE SUMMARY

Welcome to the Andrew Haslam / Legal IT Insider buyer's guide to litigation support (or eDisclosure/Discovery) systems. As with previous editions, this version has been released in Spring to ensure that the latest information from the LegalTech exhibition in New York has been incorporated.

The target audience for the Guide are those individuals who understand they have a requirement, but do not know how to proceed with the next steps. It is assumed that people within organisations that have a litigation support function, will turn to them in the first instance for advice, but might use this document as a primer on what is available.

Possible readers of the Guide are end users of these systems, be they lawyers, barristers, in-house counsel, or IT departments. The Guide does not purport to identify the "best" software or supplier in the marketplace, but instead aims to supply information to allow users to arrive a shortlist of potential vendors, with a procurement exercise being the next logical step.

The Guide is based on Andrew Haslam's general experience in the marketplace, also drawing from a number of vendor procurement exercises. The information on firms and software tools has been provided by the organisations themselves, albeit moderated by the author.

The remainder of the Guide contains a background to the marketplace, looking in more detail at the scope of the document and potential users, and an overview of the EDRM model. A Chapter on the technology areas provides a more detailed examination of the processes that underpin the EDRM schematic, followed by an in-depth survey of the marketplace, the vendors, current issues and potential problems.

A procurement Chapter provides the "meat" of the document with example requirements for scanning, coding, data collection and litigation support services. There is a reference Chapter for additional links to other useful sites and then the specific details of suppliers and software.

Andrew is currently employed as the UK eDisclosure Project Manager for Squire Patton Boggs (UK) LLP, all opinion within the Guide is Andrew's personal viewpoint and does not represent any views, opinions or strategies of Squire Patton Boggs.

2. GUIDE STRUCTURE

All of the numbers shown under the Where column are hyperlinked. Hover the mouse over the number and use Ctrl + Left Mouse Click to jump to that Section.

Topic	Where
What is eDisclosure (and what is it not.)	3.1
The EDRM model, which is explained both in overview and detail, shows what legal involvement is required at each stage, and where you might get help from. The model covers the following stages:	3.2
• Information Management.	3.3
• Identification of what data you might need.	3.4
• Preservation of that information.	3.5
• Collecting the data without “polluting” it.	3.6
• Processing the data to cull it down to potentially relevant material.	3.7
• Reviewing it.	3.8
• Conducting analysis on the reviewed information	3.9
• Producing, either at the disclosure stage or for trial.	3.10
• Presenting the information in court.	3.11
A short resume of the EDRM model, and how it works.	3.12
A description of Computer Assisted review (for advanced readers).	3.13
Why cooperation is needed and why it isn't collaboration.	3.13.10
A final summary of the Chapter.	3.15

The remainder of the Guide gives more information on eDisclosure, issues you might encounter and how to procure the right systems for your needs from the correct type of vendor.

Chapter 2 – Guide Structure

Topic	Where
An examination of the different technology areas to give context to the Chapters that follow.	4
Three subjects about which readers need to be aware, but which are not examined in detail in this Guide: <ul style="list-style-type: none"> • Litigation Readiness. • Records Information Management / GDPR • Email archiving. 	4.1
Collecting data, both generic and in an evidentially sound manner.	4.2
Scanning (because cases still involve paper)	4.3
Objective and Subjective coding, what are they?	4.4
Litigation support tools, a brief overview of the area.	4.5
Court room presentation systems.	4.6

Topic	Where
Having given context in terms of the relevant technology areas, a number of specific aspects of the marketplace are examined.	5
First, a brief background to the changing legal environment, is provided.	5.1
A historical perspective of the marketplace grouped by different types of available tools is given, including: <ul style="list-style-type: none"> • A general overview of the technology. • Early Data Assessment (tools for getting a handle on the mass of data. • Litigation Support Products (the things that do the review and analysis bit). • Predictive coding or other terms for Computer Assisted Review. 	5.2
A review of the marketplace is provided in terms of describing the different types of service providers (which for these purposes covers both software and hardware) that are out there, grouped by vendor type: <ul style="list-style-type: none"> • A bit of background to the marketplace. • Consultancy firms, the “supermodels” and the rest. • Software specific organisations (firms that own their own software) • Solutions / Bureau organisations (firms that use someone else’s software). • Outsourcing, a brief mention to provide full coverage. 	5.3

Chapter 2 – Guide Structure

Topic	Where
<p>Then the Guide goes on to explore the current practical “hot topics” in this area, about which you should be aware:</p> <ul style="list-style-type: none"> • Clustering, that is automatically grouping similar documents together by software means. • Email threading, so that you can just read the “top” email of the thread. • Automatic language translation, not for the court but for quick and dirty review work. • Digital audio files, can be reviewed as if they were text, that is you can jump straight to a word in the middle of an hour’s recording. • Computer Assisted Review. • Collecting data from social media. • I just want to read the emails, and not spend a fortune putting the stuff into a review system. • Charging models; How much? • Redaction for native formats. • Emails with non-relevant attachments. 	5.4
<p>The Guide then identifies a number of key issues you should raise with any service provider:</p> <ul style="list-style-type: none"> • Adding Privilege to just one attachment to an email. Because some products don’t let you do this. • Re-unitisation of images of paper documents. Because paper is still with us, but some products don’t like it. • Names normalisation, how to tame all the different versions of your email address. • Data collection by either the client or your IT department. Don’t Do It. • Some issues when working in Native mode. The “buried treasure” of track changes in Word, speaker notes in PowerPoint and comments in Excel cells. 	5.5
<p>A list of the main UK vendors sorted by:</p> <ul style="list-style-type: none"> • Consultancy firms (both large and medium) • Software specific organisations • Solutions / Bureau organisations • Forensic Firms 	5.6
<p>Followed by a list of the main software products sorted by reference to main stages of the EDRM, ie. Software for:</p> <ul style="list-style-type: none"> • Collection. • Processing. 	5.7

Chapter 2 – Guide Structure

<ul style="list-style-type: none"> • Review. • Analytics. 	
And a list of all the "Plugins" you can get for Relativity.	5.8

Topic	Where
All you every wanted to know about procurement but were too afraid to ask.	6
Vendor pricing, how they arrive at their cost model and how to get the best deal.	6.1
Advice on the overall approach, which is to arrive at the point of having potential vendors demonstrating their software to you preferably with your data.	6.2
“Cut and paste” sections for each of the following areas, that you can just drop into your procurement document, or use a demonstration checklist. <ul style="list-style-type: none"> • Scanning, because paper is still with us. • Unitisation and coding. • Data collection, because neither you nor the client should be doing this. • Litigation support systems, the heart of the Chapter, with lots of detail. • Processing small volumes of ESI, AKA, how I can just read the emails in the case without spending any money. 	6.3 6.4 6.5 6.6 6.7
A very nice picture that shows how all of this hangs together.	6.8
A final summary of the best bits in this Chapter.	6.9

Topic	Where
Other resources. A list of other websites that might help you gain greater understanding about the topic of eDisclosure. Includes a link to the TeCSA page holding information on the TCC protocol and a copy of the TCC Legal/EDRM Timeline (complete with hyperlinks to the relevant parts of CPR). Also a link to the ILTA webpage for the exchange protocol.	7

Topic	Where
The "Yellow pages" listing of (mainly) UK vendors and software.	
Vendor Information	8.1
Software Information	8.2

Topic	Annex
A glossary of all the technical terms used throughout the Guide.	A
A blank copy of the form used by suppliers to provide details of themselves	B

Chapter 2 – Guide Structure

and the software products they use.	
-------------------------------------	--

Throughout the Guide the following boxes will be used to draw your attention to specific points.



NOTE: Brief Description

Used to draw attention to specific elements of the text.



BEST PRACTICE: Brief Description

Details a point of best practice that users are advised to follow.



WARNING: Brief Description

Warns users of any potential issues.

3. EDISCLOSURE – AN INTRODUCTION

The purpose of this Chapter is to take the reader through the process of eDisclosure, starting with a definition of what it means, and what it does not mean, and then progressing (by means of an industry standard model) through the various stages of the procedure. At the end, there is a more advanced section on the specific area of Computer Assisted Review or CAR, but this can be skipped until required.

3.1 Definition

A simplistic definition is that eDisclosure is all about the disclosure of electronic material. However we need to dig a little deeper into that statement of the obvious.

There are two parts to the definition; the words "disclosure" and "electronic material". Let's explore the second one in a little more detail. Electronic information refers to the "stuff" that is within emails, Word documents, Excel spreadsheets and PowerPoint slide shows. This is the level that most readers will need to interact with for eDisclosure. The term also includes databases, social media (Facebook, LinkedIn, Twitter), digital audio such as recorded conversations in deal rooms, support centres et al, images, mobile phones, tablet devices (i.e. iPads and their ilk) and a host of other increasingly more exotic types/locations. All of this is known as Electronically Stored Information or ESI.

The definition of eDisclosure then becomes the process of identifying, collecting, processing, analysing, reviewing and presenting ESI for legal proceedings.

Because so much of the software in this area comes from the United States, it is as well to recognise the synonym eDiscovery, which is the American term for eDisclosure.

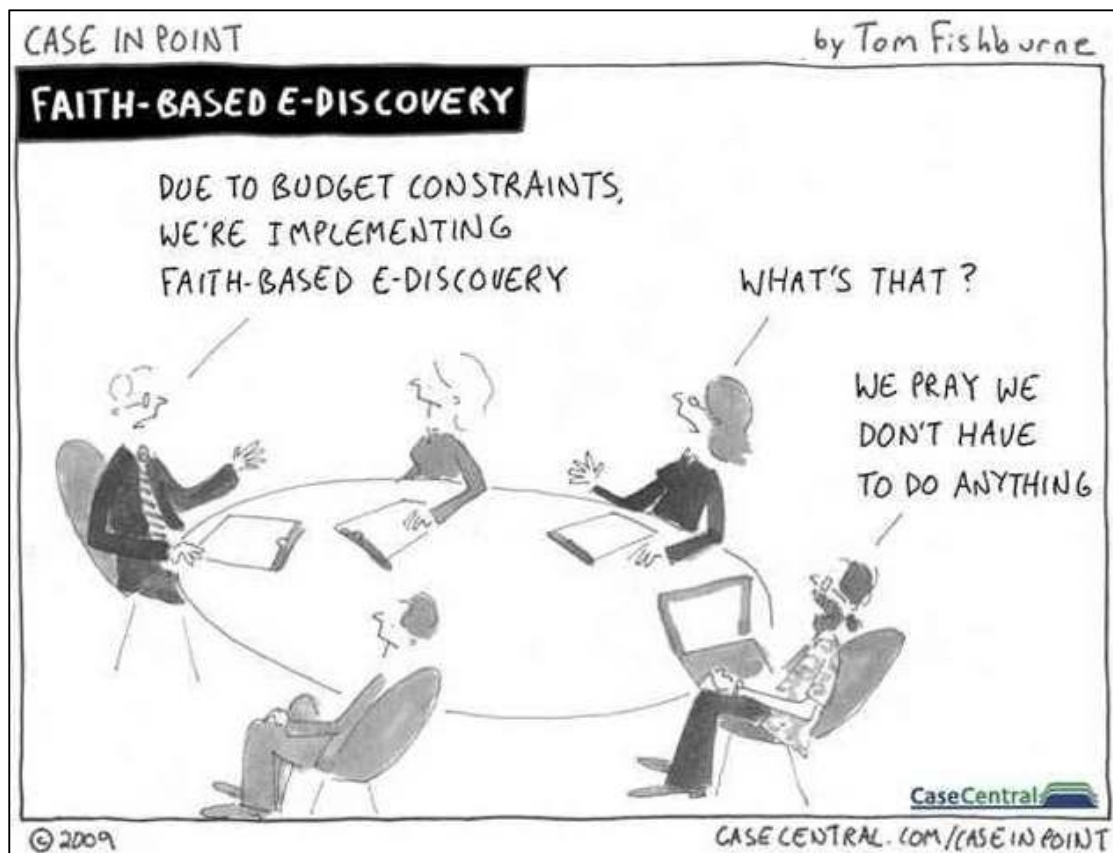

For the sake of completeness, eDisclosure is NOT the process of agreeing the electronic media by which information will be transferred. When disclosure was all about transferring images of pieces of paper between legal entities, there used to be

discussions on format might be used for the images, and which kinds of physical media could be used to hold the images and their data, be it "floppy disks", tapes or a memory stick. This discussion used to be incorrectly labelled as "eDisclosure", and is mentioned here to dispel any legacy misunderstandings.

3.2 EDRM Model

As you would expect for a technical process, there is an official model showing the various steps involved in the whole procedure. This is known as the Electronic Discovery Reference Model (EDRM). The model is discussed in great detail at www.edrm.net, but for the purposes of this report the standard graphic used to give an overview of the approach is shown below.

If you want to see how the various stages of the EDRM process relate to the procedural requirements contained in the CPR and the related Practice Direction, and what this means in terms of the action that you should be taking in the context of eDisclosure and when, you should refer to the eDisclosure Timeline in section 7.10.

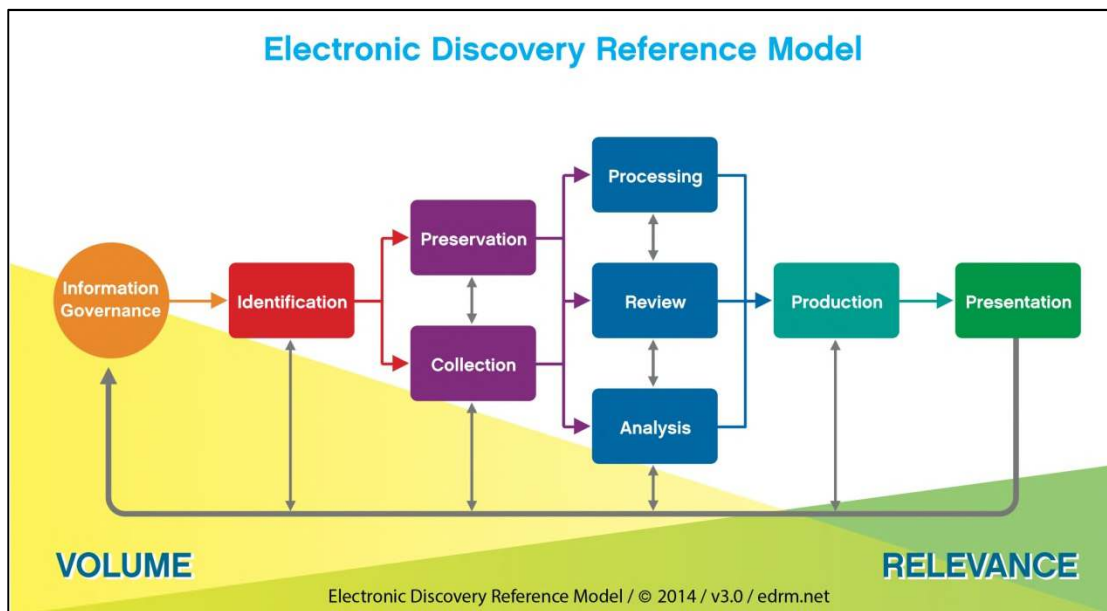

NOTE: Circular Processes

Some of the lines used to link the boxes have arrowheads at each end. This implies (and very often means) that the workflow "loops" around and that having done one box, you need to go back and repeat some previous processes.

The background in the graphic shows the volume of data decreasing as the various stages are completed, with a corresponding rise in the identification of relevant material. The various processes involved in eDisclosure are shown as discrete boxes with workflows between them. The main use of the model for this review is to provide a "shorthand" to explain the functionality that different software products provide.

For example a company specialising in area of Records Information Management, email archiving and the ability to "freeze" documents within a client environment in order to meet the requirements of disclosure (the US "Legal Hold" concept), might state that they "work in the left hand side of the EDRM model". A forensic firm might focus on the purple Preservation and Collection areas, whereas a litigation support software firm might have literature showing them focused on the blue boxes of Processing, Review and Analysis.

The following sections go through each of the "boxes" of the model and look at three things:

3.2.1 Description

The official description of the individual process/procedure.

3.2.2 Legal Implications

What you as a lawyer might become involved in within this particular process.

3.2.3 Who can help

A brief overview of the types of services and/or software products you might need to support you in this process. Wherever possible software products are named, though these are non-exclusive lists.

3.3 Information Governance

3.3.1 Description

Getting your electronic house in order to mitigate risk & expenses should eDiscovery become an issue, from initial creation of electronically stored information through its final disposition.

3.3.2 Legal Implications

This is an area also known as Litigation Readiness and is normally conducted by the client. You might be called upon to assist in terms of providing advice on data retention requirements for a specific industry.

3.3.3 Who can help

Normally the preserve of the larger consultancy firms working with their clients.

 **NOTE: There's a BD opportunity here**

Why not approach your clients (possibly with a technology partner by your side) and engage them in conversations about becoming litigation ready. You supply the detailed legal and business specific knowledge and the client is better prepared for the "evil day" of litigation.

3.4 Identification

3.4.1 Description

Locating potential sources of ESI & determining its scope, breadth & depth.

3.4.2 Legal Implications

This is the initial stage where the client comes to you and explains their problem. Using a combination of your legal knowledge and their understanding of the organisation they work for, you should start to get an idea of where the ESI might be located. You might want to incorporate a rough outline of the scope in your initial client care letter, you

might be happy with going on what the client tells you (it is their data after all), or you might want to delve a little deeper into what data silo's exist.

This is very much a "horses for courses" area. A good rule of thumb is; do you know enough about the client and their technology to run a "sanity check" over what they are telling you?" If not, you might want to get some professional help to try and uncover the "nasties", before they bite you downstream.

3.4.3 Who can help

Some eDisclosure suppliers specialise in producing something called a "data map". This is NOT a technical document showing all the servers and other bits and pieces that makes up the client's IT infrastructure. Rather it is a written description (possibly with a diagram or two) of where the various data sources are. For example; *"Most of the information is stored on the email servers, but some is on the back-up tapes, and there is a company the main firm took over last year that has got its own IT infrastructure which will need to be examined."*



BEST PRACTICE: Build a "Data Map" as soon as possible

Should be a single piece of A4 that describes where the data is stored and any issues surrounding it. Print it out and have it on the front of the Matter file. The overall concept of a "Data Map" is embodied in Section 2 of the DRD.

3.5 Preservation

3.5.1 Description

Ensuring that ESI is protected against inappropriate alteration or destruction.

3.5.2 Legal Implications

Once you have determined the possible scope of the areas you might (or definitely will) be collecting data from, you need to ensure that the client doesn't delete or damage the ESI in those locations. Again this might be something for your initial engagement letter and you might need technical help. You might cover things like; stopping the re-use of back-up tapes (it can be cheaper to buy a whole new sets of tapes that over-write important evidence), or removing the limits on email in-boxes that cause emails over 60 days old to be deleted, or putting a hold on the re-use of the PC, that was used by the employee who is now suing your client.

3.5.3 Who can help

There are very expensive, mainly US based tools that will enforce the American concept of "legal hold". If your client has got this kind of software in place, they are probably involved in serial litigation and you won't be reading this kind of Guide.

The key area that causes problems is when there is a "disconnect" between the client and their IT department. You might want to make sure that someone from the client's IT department is involved in the initial meetings/conversations so that they can understand what you are asking the client to do. If you are not comfortable with your level of technical knowledge you might want to take along support from a vendor so they can talk "Geek to Geek".



WARNING: Forget the Client's IT staff at your peril

Make sure the Client's IT people understand what data you are preserving, so that they don't inadvertently destroy it as part of their normal business practice.

3.6 Collection

3.6.1 Description

Gathering ESI for further use in the e-discovery process (processing, review, etc.).

3.6.2 Legal Implications

As a rough guide, there are two kinds of data collection, those that require a forensic process (complete with chain of evidence documentation) which is normally in cases of fraud, and the rest, where you just need to collect the data in a competent manner. The first group is a specialist area, and if you are involved in this kind of proceedings, you probably have got a "tame" forensic investigator that you can use, if not you need to find one. The forensic data capture might also involve things like retrieving data from mobile phones, making forensic copies of PC's or other computer equipment, and all other kinds of highly specific activities.

For the more general data collection requirement, there are issues here, more fully explored in subsequent chapters. Suffice it to say, that it is best to have a qualified individual or service provider collect the information and there are pitfalls involved in letting the client do it for themselves. However, in some cases this might be OK.

There are two schools of thought on the scope of data collection. One is that you collect very broadly (so you only disturb the client once) and use the downstream processing to winnow out what you need. The other is that you do a focused collection and run the risk of having to come back and widen the scope. Each is valid, and they are non-exclusive, in that you can start focused and (if the case progresses/warrants it) come back later and do a wider collection for downstream culling.

This is where an understanding of the case, and where the information is stored is invaluable, as you can then make informed decisions. With, of course the price of the different options and how it affects the downstream processing very much to the forefront of people's minds.



WARNING: Badly collected data can lose you the case

Leave data collection to the experts. If the client offers to do to save money, be very careful and make sure they understand the implications if they get it wrong. It is NOT just a case of copying things from one place to another.

3.6.3 Who can help

The forensic data collection organisations are a specific grouping of service providers. Make sure that you get a forensics company and not just a litigation support service provider that has sent someone on a data collection course. They tend to use products such as Guidance EnCase or Access Data's FTK toolkit to carry out the collection process, indeed these products are often used by the other group as well, just without the formalised chain of evidence documentation. The key thing is that people in this first group are used to appearing in court as an expert witness to explain how they obtained the specific piece of information.

The second type of data collection can be handled by a number of vendors, though in practice using the specialist organisations and dispensing with the formal side of things is a sound tactic.

3.7 Processing

3.7.1 Description

Reducing the volume of ESI and converting it, if necessary, to forms more suitable for review & analysis.

3.7.2 Legal Implications

The "shorthand" term for this stage is Early Case Assessment (ECA), or more accurately Early Data Assessment. This is where the range of options open to you increases quite dramatically. In the main the processing goes through two stages; first the data is "cleansed" in that unwanted types of information are automatically removed, this process can also involve the identification of duplicate versions of emails etc. Second, the data is loaded into a tool that allows the user to identify the information they want to take forward into the next stage.

The capabilities of the tools at this stage are quite bewildering, but in the main, you are trying to identify the information that you will want for your case, so an understanding of the key people involved in the matter (normally called data "Custodians" in techie speak) is good, as well as the date range that covers when key events happened. You might have an idea of the kinds of terms or keywords that would be useful to search on, but there are other much more powerful technologies at your fingertips that will surpass the results of keywords.

The key to getting maximum benefit from this stage is for you to team up with a sympathetic vendor and let them drive the technical process, whilst you supply the background and legal requirements of the matter.



BEST PRACTICE: Build a partnership with a service provider

Let the service provider drive the processing software; you should focus on giving them the salient points of the case issues, so that you can identify and cull out unwanted data.

3.7.3 Who can help

The choice of software here is split into two groups. On the one hand there are products specifically designed to work in this area. These range from software that third party suppliers use such as Veritas eDiscovery Platform, IPRO's eCapture tool, or Nuix, through to tools specifically designed by suppliers for this area, like the snappily named MM/PC tool from eMag. There are a number of these specialist tools, and the mention of those above is not to elevate them above the rest, purely to show examples of the genre.

Secondly, there are products from the next stages of the process (Review & Analysis), that incorporate functionality for this step as well. Products such as Ringtail, come to mind, as does Relativity's Relativity Processor software, and Opentext (used to be

called Recommend) offerings. Again, these are mentioned as examples and not as an exclusive list.

In the first few editions of the Guide, the Early Data Assessment modules of the "All in One" products did not match the functionality provided by dedicated tools. This is no longer the case, which is good news in one way as it adds to the choices available to you, and bad news in another, as it adds complexity to the selection process in this area.

 **NOTE: Controlling costs starts here**

Getting a good deal on processing costs is as important as having the latest technology. There is no escape from this, you have to put in some effort in building a relationship with a service provider in order to understand your option.

3.8 Review

3.8.1 Description

Evaluating ESI for relevance & privilege.

3.8.2 Legal Implications

For many, this and the next stage form the hub of the eDisclosure process. The products mentioned here will be the environment in which you and your legal team will conduct most (if not all) of your on-line interaction with the data. The first half of the equation is the ability to review ESI and assign values for: Relevance, Privilege, Trade Secret, Personal Data, and as many case-specific topics as you can shake a stick at. By the time you are in this stage, you will (hopefully) know what the issues are that you will be fighting the case on, and the various criteria you will apply to determine relevance et al. Your role will probably be to oversee the team that is carrying out this review work, though in smaller cases you might be doing the work yourself.

For large scale review exercises; you might have to recruit contract legal staff to do the work under supervision or farm the work out to one of the London based managed review facilities. You might have a "near shore" option of a cheaper office outside of London, or you might be involved with an off-shore Legal Processing Operation such as Integreon (India) or Exigent (South Africa). In essence you will direct the team (whatever the size and geographical location) and provide overall Quality Assurance back to the Client.

3.8.3 Who can help

The short answer to this one, is a lot of service providers. There is a lot more analysis of the firms and their products in the Chapters after this, but the broad split is between organisations that have their own software, and specialist software products that are supplied by different types of third party vendors be they consultancies (of different sizes) or more generic companies (that come from different backgrounds). There is a bewildering mix of software functionality and supplier personnel that combine to give you a multitude of options.

The key is that you should go through a procurement exercise before you are deep in the middle of a case, and thus make the decision in a rational cost effective manner,

and not as a result of a frantic phone call to the first service provider you can find on a Friday afternoon.

That is what the rest of this Guide is about.

 **NOTE: What works for one firm, doesn't for another.**

The "right" software for law firms, varies according to the people on the legal staff, the kind of law they specialise in, the functionality of the software and the "chemistry" with the people from the service provider.

3.9 Analysis

3.9.1 Description

Evaluating ESI for content & context, including key patterns, topics, people & discussion.

3.9.2 Legal Implications

This stage is so interwoven with the previous one, that though they are separated for technical reasons, in practical terms they will often take place within the same piece of software (albeit in some cases with the assistance of specialist plug-in modules).

The trick here is to understand what you need to do in order to meet the legal requirements of the case, and then how the technology can help you. By legal requirements I mean the issues of the matter as bounded by the court, cost and time. There is a scale of software tools available, and which ones you use are defined by the case, not by the product.

I find a useful analogy is the way in which it is possible to capture TV programs so they can be watched when we like. At the bottom end of the scale are VHS / Betamax video recorders, which are good for looking at something from start to end, but that's about it. So if you want to do a linear review in which you look at virtually every bit of ESI from "document" one to one million, then there are products that are the equivalent of a VHS player that will help you do just that.

If, however, you have a more complex viewing requirement and want the equivalent of Sky HD+ box that allows you to record three shows at once, pause live TV, access the past 7 days of shows and download movies from on-line services, you want the litigation support products with more functionality.

The elephant in this particular room that everyone is avoiding is the concept of Computer Assisted Review or CAR. At this stage all we will do is acknowledge its existence, note that it has a formal definition in a Section or to, and hold that thought until we get to the following Chapters which give you an idea of all the different technologies that are available.

 **BEST PRACTICE: Understand the "what", not the "how".**

No-one (particularly the Judiciary) will expect you to be able to explain the workings of the software. If you build an approach that samples the output to show it is working, then you have the basis for agreeing/arguing with your opponent at the first CMC.

3.9.3 Who can help

Same as before. Lots of service providers can help. The trick is to select one who can become a trusted partner, before it all starts getting too hectic.

3.10 Production

3.10.1 Description

Delivering ESI to others in appropriate forms & using appropriate delivery mechanisms.

3.10.2 Legal Implications

You will want (have) to agree with the other side the scope of what you are delivering. The technical details of what is being handed over can be left to the service providers with the following exception.

It is assumed that the majority of the cases that readers of this Guide are involved in will focus on emails and their attachments, which will mainly be MS Office outputs in terms of Word, Excel and PowerPoint, with some PDF's thrown in. The battleground here can be the format of those ESI items. Word, Excel, PowerPoint exist in what is called "Native" mode inside their programs, that is you can modify and change the contents of the document, spreadsheet or presentation. Those Native documents have something called metadata associated with them, things like the original creator of the document, the date it was last printed etc. For Excel and PowerPoint, unless the ESI is handed over in Native mode, it isn't much use to the other side, so they will (quite rightly) insist upon it being handed over in that form. Word can cause all kinds of headaches, in that it can contain "Track Changes" which in turn may or may not hold privilege information etc. An option (reached by agreement with the other side) might be to create text searchable PDF's and only hand those over.

If the opposition suggests only giving you "TIFF" images of the ESI, you should reject it.

It is sufficient for this level of explanation to know that there are issues in the production of ESI and be aware of them and your preferred approach long before you start engaging with the other side.



WARNING: Don't "degrade" information

Neither you nor the other side should be taking 100% searchable ESI and turning it into images of printed pages. Those kind of games are contrary to Paragraph 34 of PD 31B and could result in an adverse order for costs. If your matter falls within the scope of CPR PD 51U (the eDisclosure Pilot) then the default mode for data exchange is "Native".

3.10.3 Who can help

Whoever is supporting your litigation software should take care of the technical aspects of exchanging information. You should work with them in understanding the implications of the options that the opposition give to you. A useful best practice protocol and guidelines is available for free [here](#).

3.11 Presentation

 **NOTE: Used to be only for the specialist few**

It is rare that you get to use presentation systems such as those deployed in the Leveson enquiry. Of more likelihood is a request for a set of linked PDF's and that is something the service providers will happily do for you. Since 2013 and the advent of the Magnum product from Opus 2, you are more likely to find technology in the court room.

3.11.1 Description

Displaying ESI before audiences (at depositions, hearings, trials, etc.), especially in native & near-native forms, to elicit further information, validate existing facts or positions, or persuade an audience.

3.11.2 Legal Implications

This used to be a very US centric part of the model, and not something the majority of users of this Guide would come across. However, the advent in 2013 of the Magnum system from Opus 2, and in 2014 CaseLines from NetMaster Solutions Ltd, mean that if your case does make it all the way to court, you might well be using an computer system to help you. At a lessor level the ability to create a linked "bundle" of PDF documents is something more firms are becoming aware of, and using where appropriate. 2017 saw the arrival of the XBundle software suite in this area. 2018 ushered in both the TMX trial presentation product from Epiq, aiming to provide competition for Opus 2 and the marketing of the eponymous Bundledocs for the PDF linking solutions.

3.11.3 Who can help

In England and Wales this is still a specialist area and readers will be able to find the suppliers very easily.

3.12 EDRM Summary

At the start of the process it is about you establishing the scope of the case, identifying the real issues, and then designing and driving the data collection and culling in an informed manner. You should NOT have to get involved in actual processing of data.

Once you are into the Review and Analysis stages, there is a very large range of options. The best advice is to carry out a procurement exercise, were you try as much as possible to compare Apples with Apples. That is what the rest of this Guide is about.

3.13 CARRM Model

 **NOTE: For Advanced Readers only**

This Section is only for those individuals who are contemplating the use of Computer Assisted Review or CAR. First time readers can probably skip this bit and come back to it when they need to.

In December 2012, the EDRM team published a draft model and definitions for the area of Predictive Coding, otherwise known as Technology Assisted Review (TAR) or, as they (and a lot of other people) prefer to call it, Computer Assisted Review (CAR).

The model shown below is followed by the text from the EDRM site.

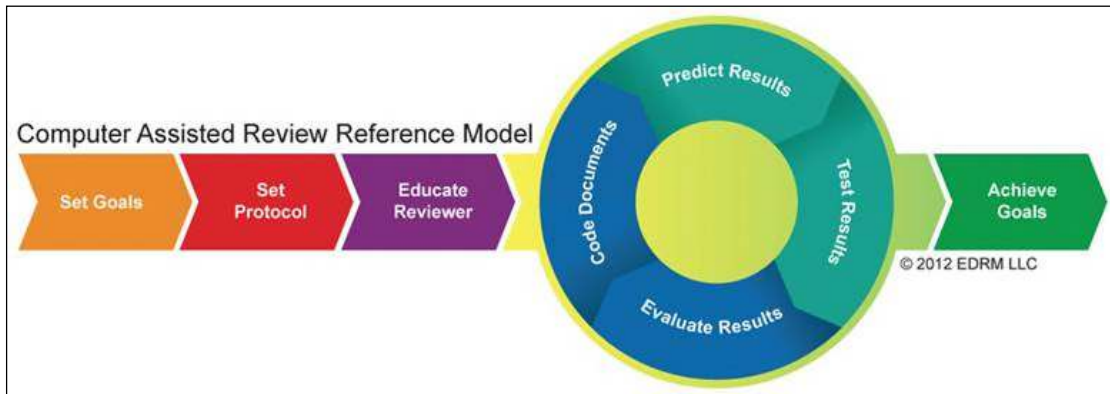

3.13.1 EDRM's Computer Assisted Review Reference Model

Computer Assisted Review (CAR) is a process of having computer software electronically classify documents based on input from expert reviewers, in an effort to expedite the organization and prioritization of the document collection. The computer classification may include broad topics pertaining to discovery responsiveness, privilege, and other designated issues. CAR may dramatically reduce the time and cost of reviewing ESI, by reducing the amount of human review needed on documents classified as potentially non-material.

The EDRM Search team has prepared a draft Computer Assisted Review Reference Model (CARRM) to document the steps of the process. This model represents joint efforts of the best known providers in Computer Assisted Review – Autonomy, an HP Company; Daegis; Exterro; Falcon Discovery; FTI Consulting; kCura; KPMG LLP; Kroll Ontrack; NightOwl Discovery; and Recomind – as well as leaders from Bowman & Brooke LLP; DLA Piper LLP (US); Littler Mendelson, PC; and Quarles & Brady LLP.

The Major Steps in the CARRM Process are described below

3.13.2 Set Goals

The process of deciding the outcome of the Computer Assisted Review process for a specific case. Some of the outcomes may be:

- Reduction and culling of not-relevant documents;
- Prioritization of the most substantive documents; and
- Quality control of the human reviewers.

3.13.3 Set Protocol

The process of building the human coding rules that take into account the use of CAR technology. CAR technology must be taught about the document collection by having the human reviewers submit documents to be used as examples of a particular category, e.g. Relevant documents. Creating a coding protocol that can properly incorporate the fact pattern of the case and the training requirements of the CAR system takes place at this stage. An example of a protocol determination is to decide how to treat the coding of family documents during the CAR training process.

3.13.4 Educate Reviewer

The process of transferring the review protocol information to the human reviewers prior to the start of the CAR Review.

3.13.5 Code Documents

The process of human reviewers applying subjective coding decisions to documents in an effort to adequately train the CAR system to “understand” the boundaries of a category, e.g. Relevancy.

3.13.6 Predict Results

The process of the CAR system applying the information “learned” from the human reviewers and classifying a selected document corpus with pre-determined labels.

3.13.7 Test Results

The process of human reviewers using a validation process, typically statistical sampling, in an effort to create a meaningful metric of CAR performance. The metrics can take many forms, they may include estimates in defect counts in the classified population, or use information retrieval metrics like Precision, Recall and F1.

3.13.8 Evaluate Results

The process of the review team deciding if the CAR system has achieved the goals of anticipated by the review team.

3.13.9 Achieve Goals

The process of ending the CAR workflow and moving to the next phase in the review lifecycle, e.g. Privilege Review.

WARNING: Driving a CAR needs skill.

CAR technology is very powerful, but needs to be understood. A degree of mathematical skills is required to both use the tool fully and explain the methodology to the other side. If you don't have those skills, consider adding them to your legal team, possibly from the supplier of the product you are using.

TAR / CAR is mandated in the eDisclosure pilot for any matter where the review scope is over 50,000 documents. You need to bear this in mind when selecting a supplier.

3.13.10 CAR is evolving

Some suppliers are now talking about TAR/CAR 2.0, implying that there has been an evolution in the approach to this process. More detail on this at 5.4.5.

3.14 Cooperation in England and Wales

Though not part of the EDRM model, this part of the Guide would not be complete without emphasising the focus on cooperation for the eDisclosure process within England and Wales. Practice Direction 31B requires that "the parties and their legal representatives must, before the first case management conference, discuss the use of technology in the management of Electronic Documents and the conduct of proceedings". PD 51U takes the emphasis on cooperation a lot further in the approach embodied in the joint drafting of the Disclosure Review Document (DRD).

Consider a meeting with the other side where both parties have; their legal representation, the client(s), the client's IT representative(s) and the litigation support providers. Use this to agree the various processes you will undertake and how the information will be shared. There is still plenty of room for argument on all the other issues of the case, but in this area you are expected to present a united front to the Judge.

If you can't agree then you can apply for directions from the court, but this could be a risky business with no one liking the outcome. Far better to have discussed and agreed up front, and the earlier in the process the better. In some cases engaging an experienced neutral mediator to facilitate the parties in reaching a consensus may be a more satisfactory way of resolving disputes which may arise.



BEST PRACTICE: Cooperation is not collaboration.

Working with the other side to smooth the path of eDisclosure is essential. You can still put your arguments and fight your case, just don't waste time and effort being obstructive. It will almost certainly add to the costs.

3.15 Overall Summary

By this stage a reader should be comfortable with the definition of eDisclosure and the various stages it encompasses. They should also be familiar (at a high level) of what involvement they as a lawyer might have with each part of the process and what tools and service providers are available to help them.

To summarise the current position, most of the significant "players" in the litigation software world have similar capabilities, albeit they might be grouped as ECA on one hand, or litigation support on the other. The main products are truly Unicode compliant, have near duplicate facilities, "cluster" data into concepts without intervention from users, as well delivering a rich search environment and the ability to easily manipulate the results of enquiries.

The differences are evident in which area of the EDRM the product addresses. The ECA tools are far more focused on processing large volumes of emails and their attachments, with emphasis on various techniques to try and identify the potentially relevant data. Litigation support software has more focus on the review of documents for relevance and privilege, and the preparation of a case around identified themes, leading to a disclosure exchange and downstream courtroom production. Confusion arises because the various products are continuing to mature by absorbing functionality from competitors. Thus ECA tools drift into the right of the EDRM and litigation support products to the left.

Now we add to this complex mix the whole concept of Computer Assisted Review (CAR) which can be presented as a "Black box technology that supplants lawyers, so be afraid, be very afraid", when nothing is further from the truth.

Where this leaves readers trying to assess which product they should choose, is that they have to evaluate what piece of software works best for them, and their circumstances. Unlike scanning, coding and (to some extent) forensic support services, it is not possible to select a supplier on price and functionality alone. Firms need to evaluate the software by means of demonstrations (preferably with their own data) and then (optionally) trialling rival products against each other to gain an understanding of what suits their individual unique requirements and work mix.

The remainder of this Guide aims to provide information to enable readers to achieve those aims.



NOTE: What's Next?

The rest of the Guide take you through all the things you need to know in order to procure Litigation Support services and software. If you are not at that stage yet, then you can stop now, though there is some good detail on pitfalls and technical issues in Chapter 5 you might want to skim through.

4. TECHNOLOGY AREAS

The aim of this Chapter is to provide a brief outline of the various areas of technology in order to provide context for the rest of the Guide. It is not intended to provide a comprehensive description of each area, more a taste of the requirements and an overview of the main issues to be aware of.

The Chapter first looks at those areas that are outside the main scope of the guide and then goes through the remainder in a roughly chronological sequence within the timeframe of a project.

Though the Guide mainly focuses on eDisclosure, there is mention of scanning as many cases still involve paper alongside the ESI material, so the topic is covered for completeness.

 **NOTE: Do I really need to read this?**

This gives more context and detail on the different tools that you have at your disposal. If you think you have a good enough understanding already, skip to Chapter 5.

4.1 Litigation Readiness / RIM / Email Archiving

This Section examines those technology areas which (as at this version of the guide) are outside of scope. It is included to provide background information on these areas, and might in subsequent issues also provide a springboard for the addition of more information on solutions within these topics.

4.1.1 Litigation Readiness

A common analogy is that, if litigation support and eDisclosure are the ambulance at the bottom of the cliff, then litigation readiness is the fence at the top that stops you falling over. Litigation readiness is inexorably bound up with a sound Records Management policy, and this in itself is a good efficient business practice. Indeed for some firms in the financial sectors, the demands of Sarbanes Oxley, the Financial Services Act, Basel 2 and MiFID, make a sound records management strategy an essential element of their business. Increasingly, the way in which a business handles electronic data has a value in its own right and that value is being assessed in Merger and Acquisition situations. The demands of the Bribery Act only increase the pressure for organisations to have a good grasp on the control and management of their ESI.

As well as the regulatory and compliance drivers, there are increased risks for firms involved in global transactions and a poor or badly prepared response to litigation can result in significant brand tarnishment, or even the destruction of the company. On a more pragmatic level, there is a good business case for controlling the spiralling costs of eDisclosure, and let us not forget, a key element of the rules changes in both the US and England, was the requirement for lawyers to specifically address the challenges of eDisclosure. That initiative was re-addressed with PD 51U in 2018.

For more information on this topic see the whitepaper stored [here](#).

4.1.2 RIM / Document Retention Policy/GDPR

As just mentioned, one of the other main elements in this area is that of policy as encapsulated by Records Information Management as a topic title, and Document Retention Policy as a specific concept. Of course what is really meant by a retention policy, is when can you delete or destroy records. That being said, a rational policy that at least removes all the superfluous duplicate copies of emails and other ESI items, does pay dividends once litigation is underway and you have to collect and process all of those individual files.

The main priority in this area is to ensure you are doing the best you can to conform to the relevant legislation, so I would advise users to approach their normal provider of legal advice for guidance.

A brief mention of GDPR. The UK made GDPR law in May 2018. At the time of writing, the situation around BREXIT is still confused, so the adequacy of the UK data protection standard as measured against the EU is unknown. There is an increasing awareness of how the level of data management required to comply with GDPR, also overlaps with litigation readiness and overall good practice.

As rule of thumb, if your matter is within the jurisdiction on England and Wales you should aim to store your data with a supplier who's servers are based in the UK. If you have EU data, you might have to consider storing the data in an EU location, depending on the outcome of BREXIT.

 **NOTE: Another BD opportunity**

Did I just hear someone say they wanted proactive legal advice on industry specific areas so I can show how much I know about your business and how I might help when it comes to litigation?.

4.1.3 Email Archiving

In a way, this is a Ronseal title, in that it does what it says on the tin, that is, these are systems that archive email. At a very high level the choices on offer mainly fall between having an in-house system, or using an external "cloud" based provider. Again at a high level, the first generation of offerings seem to be based around the in-house option, with more sophisticated functions and pricing coming for the second generation of cloud based products.

4.2 Collection – Forensic & Generic

Once the data you need has been identified, the next step is to collect the information. This is normally the preserve of vendors who provide specific services. Alternatives that normally should be avoided, are either using your own IT department to carry out the work, or letting the client's IT personnel do the collection. See Section 5.5.4 for more on the issues surrounding these choices.

The skills required to provide forensic services are very specialised, and take time to acquire. Therefore the firms operating in this area tend to be relatively small, even when the team itself is part of a large organisation such as the forensic groups of the big consultancy firms. It has been known for clients to form working relationships with specific individuals in the forensic world and remain "loyal" to that individual even when they change the organisation they work for.

The requirements tend to split into two areas, the provision of forensic services and the collection of ESI in a competent manner, which might have to conform to evidentiary standards. As a rule of thumb, forensic services are normally needed when fraud is suspected and information has to be retrieved from mainstream computer systems and/or more obscure places such as mobile phones, tablet devices and on-line social network sites.

See Section 6.5 for draft requirements within this area.

4.3 Scanning

By and large, scanning is a commodity item with most suppliers providing similar services. Prices are normally based on scanning black and white A4 pages that have printing on one side, and creating TIFF images at 200 or 300 Dots Per Inch (DPI).

Exceptions to either the colour or size of the document cause the price to increase. It is normal to get the vendor to use a process called Optical Character Recognition (OCR) to derive a text version of the images. Even the best OCR process will contain spelling mistakes, with a 99.9% accuracy rate equating to 4-5 miss-spellings on a single sheet of A4.

The main issue to watch out for in scanning is that of unitisation, in this specific area we are focused on how the images that result from a document are then "bound" together to form the set of "pages" representing the document. An issue can arise whereby the supplier carrying out the scanning obtains the images, but these are passed to a second supplier for coding purposes. The individuals in the second supplier look at the images and derive the unitisation of the documents from their interpretation of where document breaks occur, without being able to reference the original documents and thus seeing how they were stapled or attached via paperclips etc. together.

Scanning vendors have two approaches to this issue. The majority use their operators to "manually" unitise the images of the pages in the files. The more sophisticated minority have pre-prepared slip sheets that they insert within pages to show things like document start and end, paper clips, attached post-it notes etc. Their scanning software recognises all these coding forms (and strips out the images of the slip sheets) and is able to re-constitute the electronic version of the file so that it exactly matches the unitisation of the paper version.

For smaller scanning requirement, this issue is immaterial. However for larger projects (say over 20 or so lever arch files) it can cause significant problems unless addressed.

Finally it is normal practice to uniquely identify each images in some manner so that it can be referred to. The usual methodology used to be to apply BATES numbers to the document following a pre-arranged format, with a BATES number per page, though in some systems/projects this approach is now changing. As systems increasingly accept PDF's of whole documents rather than scans on individual pages, the need to individually number each page has started to recede, with document numbers being used to identify specific records.

See Section 6.3 for draft requirements within this area.

4.4 Objective & Subjective Coding

It is normal process add coding to the review system to sit alongside the images (Tiffs or PDF's) of paper documents. The coding can be either Objective or Subjective coding, with most paper documents having a minimum of Objective coding. Objective coding is that information that can be derived from the document, usually this is seven fields:

- Document Date (With an additional field to show if the date had been estimated in any way).
- Document Title.
- Document Type.
- From.
- To.
- Copyee.

Subjective coding is information that is added by a suitably qualified individual on matters such as relevance, Privilege, Trade Secret, Personal data, etc.

There is debate about the need to add Objective coding to ESI. Email does not require any additional coding as it contains the date, title and addressees within itself. Sometimes coding is added to Word documents as it can be very difficult to identify the objective information from the metadata of a Word file. However, given the volumes of ESI, such coding (even when carried out overseas by an LPO) can add significant amounts to the cost.

The issue to be aware of is that there are many different dates held within the metadata of ESI items, such as date created, date last printed, date last saved, etc. Normal practice is to use the "date last saved" as the date of the document / spreadsheet / presentation / PDF, but this might well NOT be the date shown within the item. There is no easy answer here, just a requirement to be aware of the limitations of the reliance on metadata for dating items.

4.5 Litigation Support Tools

This Section looks at the software in this area across three broad areas. A more detailed market analysis is shown in Section 5.2. whilst Section 6.6 has draft requirements within this area.

4.5.1 Early Case/Data Assessment

Once material has been collected, it is normally passed through some form of initial assessment/culling. The tools in this area allow users to "slice and dice" the information in many ways, from removing unwanted file types, grouping by date and custodian of the information, through to more sophisticated clustering of the data using semantic analysis. This last option is where the software groups "similar" items together. The computer determines what is "similar" by conducting a linguistic analysis on the content of the ESI items as well as comparing date, time and other objective data. The power of this approach is twofold. First, it groups superfluous material so that can easily be bulk coded as irrelevant. Second, the computer had no preconceptions about issues or keywords and can sometimes produce unexpected results in its grouping that a human reviewer would not have spotted.

4.5.2 Litigation Support Systems

The systems in this area are focused on the review of "documents" in preparation for initial disclosure to the other side, and (if the case progresses that far) a trial bundle. They have facilities for tagging documents for user defined issues, as well as powerful search tools and auditable production processes. The more recent tools have built in workflow that enables large scale reviews to be controlled in a much easier manner and "logic" checks that improve the Quality Control side of things. There are a range of tools on offer within this sector of the market, from reasonably "cheap and cheerful" up to top end products. That being said, most (if not all) now share common functionality and will enable users to deliver their end product, the key here is to match user requirement with the offered functionality and only buy enough to get the job done rather than over-specify the need.

4.5.3 Multi-Purpose Tools

There has been an increasing trend over the past few years for both the ECA and litigation support products to "drift" into each other's areas in terms of their functionality. Which is to be expected in a maturing marketplace. However there are also starting to appear offerings that span the whole of the two areas combined. These come in two flavours. First a single product that from the start has been designed to cover the entire spectrum, and second products that started as discrete offerings (sometimes from different companies) but by a process of acquisition and re-development now share a code base and have seamless integration between each part.

The issues here are about how well such an overarching aim can be met by a single set of software developers. The requirements of an ECA tool are quite different from that of a litigation support system and the interfaces and functionality for each area are very specific to those specific requirements. The danger here is the "Jack of all trades and Master of none" syndrome. However, as products encroach on each other's areas and as these multi-purpose tools evolve, it is probable that the successful tools of the future will span all the areas, the trick is to make sure you don't buy too soon.

4.6 Presentation Systems

The main focus in this area used to be the production of some form of court room bundle, rather than in-court presentation systems such as those deployed in major inquiries like the "Bloody Sunday", "Diana Inquest" or "Leveson" public events.

The main choice here used to be between the more traditional approach of a set of PDF files linked together into some form of eBible and more generic "cloud based" offerings. The suppliers of the eBibles tend to be those vendors with roots in scanning, whilst the preference in the cloud based solutions seems to be a choice between products from Epiq and Opus 2.

During 2013, the Magnum product from Opus 2 gained a significant amount of "traction" in the marketplace and should be explored by anyone who ends up taking a case into the courtroom.

During 2014, the CaseLines product from NetMaster solutions, was adopted by the UK Supreme court, on a trial basis, for the submission of all documents to the court. Since 1st January 2016, CaseLines has been in use at all the County Courts in England and Wales, providing a true paperless office environment. In 2018, CaseLines was adopted by the Dubai International Financial Centre (DIFC) Courts to become the first court in the Middle East to introduce a new secure cloud-based technology to allow court documents to be uploaded from anywhere in the world.

Arriving in late 2016/early 2017, was the XBundle software suite with two modules, Assemble and View, which is designed to compete in the area of creating and using electronic bundles.

Launched at LegalTech 2018 was Epiq's TMX application, a collaborative platform for case preparation and presentation. TMX is a secure, flexible, and highly scalable sharing platform that gives international clients the ability to build electronic bundles quickly and easily for court hearings and arbitrations, while delivering to the U.S.-based users, a single collaborative tool with which litigation teams can prepare case documents for depositions and trial.

5. MARKET SURVEY

This Chapter looks at the overall marketplace. It starts with a quick review on the changing UK legal environment and how that might impact upon the choice and use of technology. There then is a review of the various areas that make up the sector, followed by an analysis of the different types of vendors, and culminates in a look at the current "hot" topics for users of the guide to be aware of.

5.1 Changing Legal Environment



It is assumed that users of this guide are well acquainted with the Civil Procedure Rules (CPR) that are the formal rules for this area within the UK. Of main interest to this guide is Practice Direction 31B - Disclosure of Electronic Documents, which took effect on the 1st October 2010 and comes with an Electronic Documents questionnaire. Further information on these topics can be found in Chapter 6. The point of mentioning these changes to the rules is that they prompted an increasing awareness amongst practitioners of law that electronic information existed and had to be disclosed (the real meaning of electronic disclosure, as opposed to arguing about the media used to hand over material).

The other key driver in this area has been Lord Justice Jackson's review of Litigation Costs that was published in its final form in January 2010. The suggestions on how costs might be managed have mainly been implemented, with judicial training on costs management starting in January 2013, and the required legislation being enacted in April 2013. For the purpose of this Guide the key factor is that parties should arrive at the first Case Management Conference with a plan for eDisclosure that they have agreed with the other side. Fundamental to the changes is that Judges will have been trained to explore how the disclosure exercise will be carried out, and if the proposed approach uses technology in an appropriate manner. So the days of printing everything, or conducting a linear review with an army of legal staff, or arguing over arcane lists of broad keywords are numbered.

During 2019/20 there will be a 2 year pilot of proposed changes to the Civil Procedure Rules for disclosure. The most straightforward and factual article about the proposals is on Simmons & Simmons' [Elexica](#) site. It summarises the proposals and the main reasons for the changes, and has links to the [draft rule](#).

Lawyers need to "tool up" with technology and understand how to fully use the tools they have at their disposal. It is hoped the rest of this Guide will help them achieve this goal.

5.2 Market review

This Section of the Guide looks provides a historical review of the marketplace in two main areas. First a review of the overall evolution of the technology and second a more UK specific analysis of the changes in specific technological areas.

NOTE: What's this Section about?

Section 5.2 gives the background to the differences between the types of software providers. If you are happy accepting that some are "pears" and some are "apples" then go to Section 5.3. If you just want a list of the main software products go to Section 5.7.

5.2.1 Historical Market Review - Overall

The litigation support market is a maturing one, both in terms of the software products and the firms that provide them. The evolution of the software is best tracked by looking at a technology conference / exhibition called LegalTech that takes place in New York in January/February of each year. The author has been attending the exhibition for many years, and since 2008 produces an annual review of proceedings. The following summary is based on knowledge gained during those years as well as practical experience of different products. The summaries for the past 5 years only are shown below.

2015

Another year of consolidation in terms of the functionality of eDisclosure products with little to choose between the mainstream offerings. Some potentially disruptive events though. Microsoft bought the text analytics company Equivio, presumably to provide "good enough" eDiscovery functionality for Office 365. A number of suppliers embed Equivio within their software, as those licences run out it is assumed Microsoft will withdraw the product, leaving suppliers hunting around for alternatives.

Relativity continues its market leadership and for the first time availed itself of investment capital to build a "war chest" of some \$125M.

By the end of March, two UK litigation support suppliers should announce they have been bought by US companies to gain a foothold this side of the Atlantic.

The increased focus of products and sales continued to be within the Information Management / Governance area.

2016

As predicted, the previous year saw significant consolidation in the UK marketplace. There were two bursts of activity, with 12 days of mergers in March/April as Unified were bought by Inventus, Merrill eDisclosure by DTI and IRIS by Epiq (though that was mainly a US focused sale). In the summer, Consilio took investment capital from Shamrock and then used it to buy two early Christmas present in December as they snapped up Proven Legal Technology and Huron Legal. At the end of December Inventus themselves were acquired by RPX and early in January of this year Millnet joined forces with Advanced Discovery. Also during 2015 Veritas was spun out of Symantec, taking the Clearwell product with it which was relaunched as the Veritas eDiscovery Platform

The focus of 2016 will be increasingly on Cloud based Software as a Service (SaaS), with UK firms moving more rapidly than they might like towards a financial model where the majority of their income is derived from consultancy rather than processing and

hosting. There will inevitably be casualties along the way, so due diligence in any procurement exercise will be even more important than normal.

2017

2016 continued the consolidation of the marketplace, In March Mishcon announced a partnership with Unified to create an organisation dedicated to providing eDisclosure support to Mishcon's lawyers. Also in March, kCura liked the product Content Analyst so much that they bought the company, thus bringing control of their Computer Assisted review technology inhouse.

June saw Opentext acquire Recommind, whilst in July DTI absorbed Epiq to become the first \$1 Bn eDiscovery company. In August, Lighthouse was given \$23 M by CIT, mainly to fund expansion in the UK.

Also during the autumn, New Quest Capital partners took over Integreon, Stroz Friedberg were acquired by Aeon (to support their cybersecurity practice) and Kroll OnTrack become part of LDiscovery with their new name of KrollLDiscovery being unveiled at LegalTech.

The LegalTech show in February 2017 saw a dramatic focus on the use of Artificial Intelligence or machine learning in all areas of legal IT, with eDisclosure for once, ahead of the game with its use of CAR.

Also early in 2017, two mainly print based suppliers were taken over, K2 by Anexsys and City Docs by Apogee.

2018

This year's LegalTech saw a shift in emphasis in the supplier booths for the first time in many year's with a whole host of fledgling companies offering contract review using some form of AI/Machine learning. It will be interesting to see if any of this bleeds through into the eDisclosure world.

The pace of market consolidation slowed during 2017, though in September OpenText continued its acquisitions with the purchase of the forensic collection software company Guidance. Morae Legal and Clutch Group announced a merger, and Xact Data Discovery, Lighthouse and Advanced Discovery each acquired competitor e-discovery groups, and Inventus purchased Unified.

In a flurry of news in March 2018, Consilio and Advanced Discovery announced they were merging, to form the second largest eDiscovery company behind Epiq, whilst CloudNine bought all of the Lexis Nexis eDiscovery toolset; including Concordance and Law. It will be interesting to see how these mergers and acquisitions pan out during the rest of the year.

2019

The consolidation of the eDisclosure marketplace continued with a spate of US mergers, with the most interesting being the Jan 19 acquisition of Catalyst by OpenText in what might be a purchase to remove competition rather than continue the Catalyst product lines. In Sep 2018 Nuix bought the Ringtail software from FTI Consulting, thus giving them an "end to end" functionality capability across the EDRM model. In Oct 2018 Consilio acquired DiscoverReady further consolidating the US marketplace.

As far as the UK was concerned, the interesting news in the eDisclosure area, was the moves by both CS DISCO and Everlaw into the marketplace, mainly in competition with Relativity. Both now have UK offices, employees and clients. The depth and range of "not-Relativity" alternatives continues to develop.

5.2.2 Historical Market Review – Litigation Support Products



To understand the differences between software products, it is necessary to look a little at the history of their development and they grew to meet different challenges at different time.

Initially litigation support tools were about dealing with scanned images of paper as this was the requirement in the 90's. The tools, such as Concordance and Summation, were basic search and review environments with additional products providing the ability to look at the images. The software evolved rapidly and a new generation of vendors appeared, with Ringtail and Steelpoint (which became IntroSpect) as the leaders in this area by the time you come into 2000 / 2001. They were still based on handling large volumes of images and struggled initially as the explosion of electronically stored information (ESI) hit them. Products emerged such as Kroll Ontrack's Electronic Data Review (which became Ontrack Inview and in 2013 ediscovery.com Review), Epiq's DocuMatrix and a host of others, most of which withered, or were bought out over the years. In a reflection of the struggle going on now between more "traditional" litigation support tools and their ECA brethren, so the products initially based on images and those on ESI mimicked each other's abilities, bought out software upgrades and eventually became a more homogeneous and mature market place.

The more recent products coming to the market have learnt from existing offerings and taken the best of the functionality, but wrapped it in a far more accessible interface. This used to be the main differentiator between products, on the one hand you had Ontrack Inview, DocuMatrix and Ringtail, on the other were newer tools such as Relativity, cicayda and Viewpoint that had a far more "Outlook" type look and feel. Now, the interfaces are very similar, with a corresponding similarity in the function suite that is the "entry level" into the market.

5.2.3 Historical Market Review – ECA Products

The genesis of ECA was the explosion in volumes of disclosable material brought about by electronically stored information (ESI), a shorthand acronym for emails, Word, Excel, PowerPoint, PDF's and all the other data that organisations and individuals produce. The main concept underpinning ECA is that the software groups items of ESI together by virtue of data analytics of their contents and metadata. The initial product in this area was called Attenex (now an integrated component of FTI Consulting's Ringtail product), with the name itself meant to be "At ten times", an indication of the increase in review speed you could obtain by using the product. Over the years other products have appeared, elements of ECA have been grafted into the main litigation support products and the capabilities of the offerings have expanded, with the cost also dropping exponentially. When Attenex first appeared it had a charging model of £2,000 per GB, now ECA can be accomplished for tens of pounds per GB.

One of the other key players in this market used to be the UK based firm Autonomy. They (like Recommind) come to the arena of litigation support from a background of enterprise searching and knowledge management. Recommind realised they almost had a litigation support tool in their product and added functionality to make it work. Autonomy first bought IntroSpect to give themselves a litigation support product and re-built it around their IDOL search engine. Then they purchased iManage to give themselves a document management offering. In terms of market focus, Autonomy (more so than Recommind) was pushing for domination in the corporate environment where the three overlapping areas of Litigation Readiness (IntroSpect), Knowledge management (IDOL) and document management (iManage) exist. However the events of Autumn 2012, when HP accused Autonomy of false accounting during the takeover of Autonomy by HP means that this entire product range was under a cloud for some time. As at the date of this version of the guide, that cloud has lifted and HP are once again strongly selling Autonomy, though mainly into the Information Governance area, rather than litigation support.

The most significant current thing in the ECA world, is that it seems to have firmly breached the corporate firewall. By this I mean that the software runs inside a corporate environment and, when required, can by issue legal holds and then incorporate these into a focused search on "held" material to identify the data that needed to be processed further. Though the whole Legal Hold concept didn't really apply in the UK, there will be some clients in litigious marketplaces that this would be of interest to. Also the UK Bribery Act is providing an impetus for organisations to look again as to how they manage their electronic information. In this area, products from eDiscovery tools, and Recommind are mentioned as ones to watch.

For the moment, the focus for the UK is on the ECA tools that mainly operate outside the end client's environment. In practice this has tended to mean one of three products, Veritas eDiscovery Platform, Nuix or Digital Reef, with (up to now) only the first two really having success. It seems that lawyers prefer Veritas eDiscovery Platform to Nuix because of its interface and seemingly better functionality, Technology departments chose the speed and performance of Nuix, over what they consider to be its slightly flashier competitor. The Recommind product range incorporates both ECA and standard litigation support tools, as does Relativity with its Processor and Review offerings, Lateral Data's Viewpoint and Venio with Venio.

5.2.4 Historical Market Review – Predictive Coding Products

The phrase "Predictive Coding" is shorthand for any process that uses computing power and software algorithms to try and carry out coding of electronic documents. On one level the machine can carry out objective coding and scan the document for the data it can "recognise" to give you the From, To, Title, Date kind of material. So far so good. Next you get the programs that will "search" the document and highlight the terms that it thinks means the document should be relevant and even highly subjective calls such as Privilege.

However there are caveats. The software will only really work on fully electronic material, so you cannot get the same results on the OCR of images of scanned documents. Second, most products require the user to "seed" the review work with appropriate documents that have been reviewed by a human (normally senior) lawyer, so it is not a silver bullet that will solve all your problems. Finally, no one is (yet) suggesting that the relevance and privilege reviews are totally done by the computer, the software puts forward documents that meet criteria and asks humans to validate its choices.

What is significant, is that the documents that are not selected, are never looked at. Yet this in itself, ties into the UK approach to proportionality. To paraphrase the UK approach, there might indeed be a slight chance that a "smoking gun" exists in the far

reaches of the potentially disclosable material, however, it can be far too expensive to review everything and so that faint possibility must not be allowed to drive the review strategy.

5.3 Vendor Analysis

NOTE: And what's this Section about?

This gives the background and detail of the different types of suppliers so that you can understand the relative strengths and weaknesses of each type when you ask them to demonstrate their software. If you just want a list of the main UK organisations go to Section 5.6.

The purpose of this section is to give a brief overview of the different types of vendor that users of this Guide will encounter in the marketplace. This is done so that the relationship between the software offerings and the people that supply them is understood. It is deliberately UK focused.

5.3.1 Background / Gartner Report

The definitive guide to the eDisclosure marketplace used to be provided by the analyst firm Gartner. It published annual reviews in May of each year from 2011-15. Retailing at some \$1,500 they used to normally be obtained for free, via vendor's websites for the "cost" of an email address for marketing purposes. One of the key elements of a Gartner report is its use of a "Magic Quadrant" to categorise firms according to both their ability to deliver functionality and the completeness of their vision. It is a useful background document, but is very US centred and does not cover third party suppliers. That is the purpose of this Guide.

In 2014 one of the main themes of the reporting on the Gartner report was how similar the Magic Quadrant was to the previous year, suggesting that the market had paused and a period of consolidation was about to start. This was confirmed in 2015, with what was the final version.

5.3.2 Consultancy Firms

Up until 2010, this group was mainly the accountancy / consultancy firms in Deloitte, KPMG, E&Y, PwC, Navigant, etc. In 2010 however, two formally independent third party suppliers were bought out by firms eager to provide litigation support to their clients. Legal Inc became part of Grant Thornton and Trilantic was bought by Huron Consulting. In both cases the litigation support firm gained the financial backing and larger access to market of their "parent", though there was perceived to be a slight disruption to their ability to deliver services during the initial "bedding in" period. This dissipated during the year.

2012 saw further consolidation with 7Safe being acquired by PA Consulting at the start of the year, and in June, Palmer Legal Technology (PLT) became part of Proven, a litigation support and investigations firm. In December 2015, Proven was acquired by Consilio.

This group can realistically be split into two "camps". In one there are the "supermodels" of the big accountancy based firms, Deloitte, E&Y, KPMG, PA Consulting and PwC. This group are larger scale firms that tend to exist of a steady diet of work generated by the rest of the organisation. Some are interested in the bigger litigation projects, but users of this guide are more likely to encounter them when the client announces that they will be using their services and the law firm will just have to comply. In house counsel might have far more to do with this group, and will have their own opinion on the strengths and weaknesses they bring to any project. I have labelled

these the "supermodels" in that the litigation projects normally have to be of a certain size to warrant them "getting out of bed". If your matter is large enough to be of interest to them they can provide a premium service at (for the main) a premium price. If it's Friday and you have 1 GB of data you need to get processed by Monday, you probably don't bother with these guys, as the conflict checks alone might take the weekend, if not longer.

In the second sub-group are the relatively smaller consultancy organisations such as Consilio, FTI Consulting, Grant Thornton, and Ankura (formally Navigant). I use the words "relatively smaller" as though they might not be as large as their "supermodel" brethren, they are significant organisations in their own right and much larger than the third party suppliers they compete against. These are much faster at processing their conflict checks, taking hours rather than days, and are interested in smaller projects (using the "set a sprat to catch a mackerel" sales approach). It might be worthwhile approaching them on the ubiquitous Friday afternoon scenario, but do be aware they can take slightly longer to respond, as they come with their own QA process that does have an overhead. But if that is what you need, then they will be a Godsend.

In summary there are good people doing good work within the teams inside the large (and very large) organisations. There are pro's and con's with selecting a "larger" firm over a "smaller" one, these will emerge as each potential user evaluates their own requirements against the supplier's strengths in the procurement process.

5.3.3 Software Specific Organisations

This group is the firms that own the software that they bring to market and thus have greater control over its development path. However, obviously, their consultancy and approach to litigation services is predicated upon their own software. In the UK, this group is split between two groups, the more numerous UK arms of US based firms, and a smaller group of UK headquartered organisations.

In the first group there are firms such as; (a non-exclusive, alphabetical list follows), Aon (that used to be Stroz Friedberg), DISCO, Everlaw, Epiq, KLDDiscovery, OpenText (that used to be Recommind), and Zylab. In the second is now only eMag.

These firms are financially secure and (generally) have a depth of resources, though there is a perception that, for some of them, their project management teams always seem to be stretched. They are generally the more corporate offering as opposed the final grouping described next.

5.3.4 Solutions/Bureau Organisations

The members of this group tend to be relatively smaller firms that thrive on offering a variety of solutions to end users and can match their products to the specific requirement of a case. There is an element of this grouping that came from a scanning and coding background, with others from the forensic services area. These firms are sometimes more "nimble" than their bigger brothers and can be more focused on client care, but carry a slighter greater risk in terms of their financial standing and long term viability.

Rather than list the UK "players" here, readers should explore Chapter 8 to get a feel for the vendors that are out there and their offerings. There are significant number to choose from.

5.3.5 Outsourcing Organisations

There are a number of Legal Processing Organisations (LPO), with the majority of offerings based in either India or South Africa, with both Epiq and Integreon also having a UK base and supplying services to a number of larger law firms. These organisations tend to be software agnostic and mainly (in this marketplace) provide a cheaper option

for carrying out larger scale review work. Using these organisations is normally something that is done by the experienced litigation support client, so there is some coverage of LPO's in this guide, but not a significant amount. Again, readers should explore Chapter 8 to get a feel for the vendors that are out there and their offerings.

5.3.6 External Review Teams

There are a small number of organisations that will provide review teams of experienced legal staff (paralegals and/or lawyers). These teams can either work off-site or on your premises. The individuals are normally very familiar with a number of review tools and are agnostic in terms of the vendors. They have the advantage that the teams can be deployed very quickly and just as quickly reduced in numbers. The organisations also increasingly offer access to bilingual skills in Russian and other eastern European languages as well as the more common EU varieties. The ones in this version of the Guide include:

BCL Legal, Codex Global, Epiq, i-Lit Paralegals, Special Counsel, TransPerfect Legal Solutions.

5.3.7 Managed Review Facilities/Teams

Similar to the previous section, during 2014, there was a flurry of organisations offering managed review services within their own premises, in response to a growing demand from law firms. The suppliers offer a (normally) London based secure facility, alongside the ability to rapidly provide reviewers skilled in a specific review tool, very often with a specific language ability. All suppliers tell stories of being rung on a Thursday night with requests for "a team of 20 reviewers to work from Friday through the weekend in order to complete the project by Monday morning". If that's your idea of forward planning then these people exist to meet your needs.

The ones in this version of the Guide include:

Altlaw, Anexsys, Consilio, Epiq, KLDISCOVERY, Integreon and Inventus.

5.4 Current Issues / "What's Hot"

This Section of the guide looks at those issues that are "hot" within the marketplace. It will be revised with each version of the guide, and the author welcomes input on areas readers would like to know more about.

NOTE: Why do I need to read this

Some of these are the tools above and beyond key words, that can enable you to complete eDisclosure within a tight budget. Even if you aren't using them, the opposition might well be, so you need to know what they are talking about.

5.4.1 Clustering

Clustering is the ability to automatically group together documents with similar content. It was pioneered by Attenex and their "petri dish" visualisation of the documents, with clusters running off a spine of a shared set of keywords. Other software companies have followed suit in terms of technology, if not the way they display it. Most useful in the context of "find me all documents similar to this one", which can enable bulk actions such as making the document set relevant, or eliminating it from the review process.

5.4.2 Email Threading

Threading is the ability to display all the emails within a chain of correspondence as a single "thread". In its more sophisticated versions, any missing emails can be "inferred" by their presence in subsequent iterations of the chain, which might influence the collection decisions. The way in which a chain can branch out can also be captured, so that only a small number of emails have to be read in order to gain an understanding of the entire thread.

5.4.3 Automatic Translation

Some programs have the ability to automatically translate a number of common languages. Most can spot that the text is in a foreign language, but the ability to translate is a little less common. No one is suggesting that the translation is of evidential quality, but normally it is enough to enable an initial view to be taken in terms of relevance etc. Practical experience has thrown up one or two issues. The software does not cope well with the presence of two languages in a document, you can get a number of "false positives" with say an English email which has some French words in its address footer, being wrongly categorised as "French". Also sometimes the document is correctly identified as being in a different language, but (if the module for that language is not installed) then it is arbitrarily categorised as some other country. The software vendor in this version of the Guide is Iconic Translation Machines.

5.4.4 Audio / Video Files

A real growth area. This is the ability of certain programs (Intelligent Voice and Nexidia being two market leaders) to index digital audio – including that within video files – as if it was text and then provide functionality enabling you to search in a similar manner. So, if you have an hour of a recording, the software will take you to the 30 second slot, some 45 minutes in, that contains the words "inside dealing". A specialist tool for specialist projects, but an absolute Godsend if you have hundreds of hours of digital material to listen to. Further improvements allow the production of text, so that you can read the conversations rather than listening to them. Intelligent Voice has biometric voiceprint search capabilities, and a standalone review player for each audio file with an embedded navigable transcript, and should be seriously looked at if you have requirements in this area.

5.4.5 Computer/Technology Assisted Review

There is a school of thought that says predictive coding is set to be the most disruptive technology to effect lawyers, why is this so? The technology comes from the United States where the twin pressures of every increasing volumes of electronically stored information (ESI) coupled with a constrained financial environment, means in-house counsel are demanding law firms do more for far less fees. Though its genesis might be American, the changing way of working will have just as much impact over here.

There are a number of slightly different technologies out there, but for the purposes of this section, we will group them all under the single heading of Computer Assisted Review (CAR). with the following core approach at the heart of their products. When faced with a mass of ESI, a well-qualified person (or small number of individuals) are used to "train" the software in identifying which documents are relevant overall, important to specific topics, and (in some cases) Privileged. The training involves reviewing a batch of ESI, normally around 1,000 – 1,500 documents, which has been selected at random from the corpus of the material. The computer processes the results and provides another batch of documents, where it starts to suggest its values for relevance, topic association, etc. The reviewer codes this batch and the computer refines its algorithms, and repeats the process. Normally after five or so batches, the machine is ready to work on its own, and then codes the remainder of the collected material. What happens next depends upon the strategies adopted by the drivers of the CAR.

One possible approach is to select a level below which, the documents might be tentatively relevant, but proportionality would mean they could be discounted, say anything below 50%. At the top end of the coding spectrum, you might decide that any document that is marked between 100 and 80% is relevant and, at this stage, does not need human eyes to confirm what the computer has decided. Where you will spend time and money is reviewing the documents that the CAR process says are between 50 – 80% as these are the more marginal calls that need verification.

Using CAR technology has a number of benefits. Foremost is the significant reduction in time and cost of disclosure review work, with the experience of senior people being used up front where it makes most difference. Some cases studies show savings of over 60% in legal fees and review time.

Next, the process lends itself to a verifiable procedure, you can share samples of the documents in the different bands of relevance with the other side, thus proving the process works, without having to delve into the guts of the CAR logic engine. All studies to date, show that computers are far more consistent and accurate than humans in conducting review work, the silicon chip making no distinction between Monday morning or late on a Friday afternoon. Finally, as this is an IT technology, it is improving at an exponential rate, meaning that next year it will be twice as capable, four times so the year after that, and so on. It's a technology that is here to stay.

Be aware that from the middle to end of 2013 the next generation of CAR products started to appear split into two totally different "camps", on the one side is the more traditional pattern based approach that uses Linguistic Analysis (pattern matching) to train the software, and on the other side are products emerging from all the research on information mining carried out by the US government in the aftermath of the 9/11 terrorist attack. It's a battle that will run for some time, you just need to be aware that it's going on when the eager salesperson is in front of you. In 2016, England and Wales obtained judicial approval of CAR with precedents being established in two cases;

Pyrrho v MWB [2016] EWHC 256 (Ch) Link [here](#).

Brown v BCA Trading [2016] EWHC 1464 (Ch). Link [here](#).

A further ruling on the use (or rather miss-use) of CAR was given in 2018 :

Triumph Controls UK Ltd & Anor v Primus International Holding Co & Ors [2018] EWHC 176 (TCC). Link [here](#).

This case has interesting implications as it marks the appearance of the next iteration of CAR / TAR, that is to say continuous active learning (CAL), though as already said, it reflects on the poor use of this approach.

When used correctly, CAL is a different approach to the previous methodology of CAR / TAR. CAR has one or two subject matter experts review document to train the system in an iterative process that might take a number of batches and period of days to arrive a workable “engine”. CAL start with a group of reviewers working on documents, and “learns” from document number one onwards as to what is relevant and what isn’t. The reviewers still need to be properly supervised and the correct QC controls applied, but you can arrive a trained “engine” faster than the CAR approach. The Triumph case shows what can go wrong if the review process isn’t correctly supervised, but when the technology is used correctly it can be faster than the CAR / TAR approach.

Chris Dale has an informative article on the use of CAL [here](#).

As with all the advanced functionality mentioned in this Guide, this is an area where you need to discuss options with your supplier.

5.4.6 Collection of data from Social Media environments

As electronically stored information proliferates into different areas, so the ability to collect it from within those environments becomes more urgent. Various vendors are developing tools (or buying up companies that have done the development) to enable them to hook into LinkedIn, Facebook, Twitter, Yammer, et al and extract information in a meaningful way. Again, the need for this functionality will depend on the area the matter is within, but increasingly data stored in social media is becoming important in more and more cases.

5.4.7 Small Quantities of ESI

See Section 6.7 below. This is a constant requirement that comes through every size of procurement and articulates the real need for users to “just read the emails”. The key problem is that information is passed to lawyers in electronic format, yet (for very good reasons as far as the IT department is concerned) they are not allowed to use the firm's environment to review it. So, they are sat there with a PST of a small number of email, an email with 50 or so Word attachments, or a thumb drive with a couple of thousand items and they “just want to read them”. Providing a quick and easy solution to this requirement will be a real game changer for the various suppliers.

A number of products have come and gone in this space, See the vendor and software chapter for more details.

5.4.8 Charging Model

Just as lawyers are coming under increasing pressure on prices, so vendors are being stressed by their clients. The default model is that people will charge you by volume, so much per GB at various stages of the process. Increasingly users are looking for a fixed price solution so they have clarity of costs to pass on to their clients. In response to this, some vendors are offering a “managed solution” option that guarantees fixed pricing for users, irrespective of individual case volumes.

See Section 6.1 for more discussion on this.

5.4.9 Redaction tools for “Native” Formats

A bit of a specialist requirement, but one that could be significant if you really, really need it. What we are talking about here is the ability to redact (that is blank out the

offending text, and remove it from all search capabilities) areas within things such as Word, Excel and PowerPoint documents. Normally this involves a cumbersome process of turning the "native" item into a PDF version and then redacting the PDF, but for things such as Excel spreadsheets this is not very workable. A number of vendors are now starting to supply toolkits that let you redact within the "Native" mode. However, if you have Privileged information within a note on an Excel spreadsheet and the opposition has convinced the judge that you must supply the document in its original Native mode, this could be a lifesaver. My normal rule of thumb is that some 0.2% of documents in a collection end up being redacted, and they are Word files to start with, just how crucial the ability to redact Excel spreadsheets really is remains to be seen.

In 2015 The Payne Group produced a redaction tool that allows you to remove material from a native Excel spreadsheet. Other suppliers such as Anexsys (Formally Hobs Legal Docs) also provide Relativity plugins that enable bulk redactions of things such as personal data. Redaction is also now available for audio files and the transcripts produced from them.

As ever look through Chapter 8 for all the products.

5.4.10 Email family groups with non-relevant children

At the heart of this point is what happens when you work with native emails which nowadays is the default situation. Say you have an email with 3 attachments, two of which are deemed relevant to the matter but the third one is not. Within the review platform you will see 4 items, the email and 3 attachments. You code the email and two of the attachments as relevant, and the third attachment as non-relevant. When you carry out the production process, you hand over the original email and two of the attachments in native mode, and keep back the non-relevant item. The problem is that the email in its native mode is a container that holds the email message and the 3 attachments, so you end up handing over the non-relevant item anyway. What will happen when the other side process the load file you give them is that the separate instances of the two attachments will be de-duplicated out against the versions held within the native email, and the non-relevant item will appear in their system.

The potential issue here is what information is contained within the non-relevant item. If its superfluous data with nothing of interest within it, no problem, but what if it's a document relating to another entity that holds personal or commercially sensitive information?

In this second case, you might make an overall strategic decision to handle the email parent as if it had attachments containing redactions. In these cases, the email is converted to a PDF or Tiff format and exchanged in non-native mode, so that embedded attachments are not handed over.

This topic, will be something your third party supplier will be familiar with, you need to understand the implications of the decisions they will ask you to make. Remember, the default is to exchange in Native format, if you are not doing this you need to explain and agree your approach with the opposing side before the production deadline.

From 2018 onwards, a number of suppliers are storing emails in a .MHT format as opposed to the normal .MSG standard. The big advantage of this is that the .MHT does not include the attachments to the email, thus removing all the issues described above.

Talk to your supplier about what they can offer, for the author, this is a very significant step forward in functionality and its use should be encouraged as much as possible.

5.5 Potential Problems

This sub-Section details some of the more common issues that can be encountered in using litigation support systems. It is not to say that a software package with one of these problems is automatically excluded from your procurement, there are very often workarounds, but you need to know the issues exist so you can factor them in to your evaluation criteria.

5.5.1 Email Groups



WARNING: This can cause serious amounts of delay and cost

If there is one single issue you need to be aware of when selecting software, this is it.

In the United States it is possible to claim Privilege over an entire email family (that is an email with one or more attachments), this is not the case in the UK and other jurisdictions. However, some of the software packages used to treat the email family as a single entity and did not allow you to split out attachments because they are privileged. This can cause significant overheads at production time and should be an issue you are well aware of when selecting software. Make sure it is a question you ask of the supplier.

5.5.2 Re-unitisation of Images of Paper Documents

Most of the software on offer comes from a background of handling electronic information, emails, Word documents and the like. Now the one thing a piece of Electronically Stored Information (ESI) never does, is change its boundaries, it is what it is. Compare this with scanning, storing and coding paper based images. With the best will in the world there will be time when the images that make up a paper document need to be re-unitised, that is the coding that encompasses say 6 pages, needs now to be split into two sets of coding, one for the first three pages and one for a second document of the last three pages. Not an issue, I hear you say, we will just split up the images in the software and change the coding as needed. This is where you hit the mind-set of the R&D team for ESI based software. They have no concept of the boundaries changing and so have little, or no functionality for re-unitising paper based records. Paradoxically the "ancient" software of Concordance and original Summation could do this with no problems as they came from a paper based background, it is the "new kids on the block" that have problems.

This won't affect you, unless you have significant amounts of paper to process for your disclosure exercise, but if you are in that situation, explore with your vendor partner how they will deal with this.

5.5.3 High level allocation of alias for Names Normalisation

The issue here is the variety of names that appear during collection of emails. Not only do you get people who have different email hosts, so;

andrew.haslam@allvision.co.uk, andrew.haslam@gmail.com, andrew.haslam@etc

Also in Outlook you have the option for a "Display as:", where you can edit the text in the "Display as" field. I like to differentiate between people's personal and work email addresses, so I change the text in the "Display as:" field to reflect this, so the entry with an email address of;

andrew.haslam@allvision.co.uk, could be displayed as Andrew Haslam (Work)

Now when an email is collected, the email address shown is Andrew Haslam (Work) not andrew.haslam@allvision.co.uk.

Also if you are collecting email from within an organisation, you can get the SMTP version of this that has all kinds of letters, brackets and punctuation.

Most Early Data Assessment tools are aware of this issue and will allow you to pick a set of names to search on, so if I was trying to get all emails sent by Andrew Haslam, I could tick the boxes to get the all the variants of my name. After a while this gets really boring, particularly when you want to start doing searches of email sent to and from a group of people, each with 4 or more versions of their email address.

What (in the author's humble opinion) is needed is a facility to have a single alias, to which all the variants could be assigned, and then you could far more easily be able to conduct complex searches. From 2014 onwards some products started to incorporate this functionality into their offerings, with edt being one of the early adopters.

Or, you get the vendor to do all the heavy lifting for you, and you just tell them what you want.

5.5.4 Data Collection by Client or Law Firm's IT Department

The short version of this is used to be. Don't Let Them Do It.

The longer version, is that data collection is not a matter of copying an item of ESI. If you don't know what you are doing, when you copy something you can change all the metadata associated with a document. What does this mean in the real world?

In one of the cases I was involved in, one set of clients used to present monthly reports to their board using a PowerPoint slide deck that had Excel spreadsheets underpinning all the graphs. The dispute revolved around actions that had taken place in 2006, so copies had been made by someone (client's IT department, incompetent vendor, some gremlin along the way) of the 2006 PowerPoint shows, sometime in 2010. Except they hadn't been forensically copied, and all of the shows now had a date displayed on the first slide of sometime in 2010, not the original correct 2006 date. So there we were in 2012, coming late to the case, relying on other people's efforts and evidence, and the other side kept demanding we give them the 2006 documents and all we had were "tainted" versions with no way of now collecting the originals.

The proposal to self-collect data normally comes from a client wanting to keep their costs down. My advice used to be to caution against this, but most internal IT departments are now technically competent enough to carry out the process, though you need to make sure they are well aware of the potential dangers before you let them do this. Sometimes in-house IT can cope with most of the collection requirements, but need external assistance with the more exotic forms of data, such as that held on mobile phones, or within structured databases such as accountancy systems, etc.

In close second, comes the lawyer, also keen to cut costs who volunteers their in-house IT team to get the information. In most cases, a law firm's IT department does not have the expertise, the time nor the professional indemnity insurance to be going anywhere near a data collection. Avoid it and get a professional to do the job, then, if it does all go wrong, their insurance can take the hit, not your reputation.

5.5.5 Issues of working in "Native" formats

Most litigation support platform have viewing tools that let you look at Word, Excel and PowerPoint documents without firing up the original software. This is fine for a quick glance, but of no use at all for real review. In a number of the real life cases I've been involved in, the text that makes a document Privileged has been contained in the Track Changes comments in a Word Document. (There's a whole Section's worth here on organisations that hand over Native documents without scrubbing this kind of data, but

that's for another day). Similarly unless you look at the formula's and workings of Excel, how can you begin to understand the purpose of the spreadsheet.

The answer to this used to be that people would offer up PDF versions of the ESI. Nowadays that won't cut it and will be resisted (very strongly) by any half-awake opponent. You need to be aware of the "iceberg" of issues that collecting and review Native data brings, and (at the very least) have protocols built into your review platform so you can see reviewers have downloaded the native document to review it. Plus, that the people doing the review have the technical skills to do things like look in Word Track Changes, or know how to remove the "hide" command in Excel.

A practical point that also occurs with frequency is the case where an email has attachments that contain one or more irrelevant items. If you produce the email to the other side in Native mode, then the email will contain within it, the irrelevant documents. In some cases this doesn't matter, in others the irrelevant material contains confidential information on organisations or individuals not involved in the litigation. In these instances it is normal practice to produce the email as a multi-page PDF (or as a set of Tiff images), either way as a non-native document.

5.6 Vendor list

The following table shows the main organisations in the UK, grouped under the headings used in the previous Section. It is shown to give a start point for readers to decide whom they wish to reach out to, for demonstrations and/or quotations. A more comprehensive listing of the service providers and their software products is shown in Chapter 8.

The assignment of organisations has been a relatively arbitrary process as some suppliers could lay reasonable claim to being under more than one heading. It has been done purely to try and group like with like, and is no reflection upon competence or suitability to task. It will be up to the Reader to decide what their requirements are, and then to approach the firms that best meet those needs.

A number of organisations provide services across the EDRM model, so just because their forte is in Forensics does not de-bar them from providing a review platform, and vice versa. You need to read the rest of the Guide to work out what your requirements are, and which kind of organisation best meets your needs, or indeed, if you should interview across the range of service providers to get a feel for their relative strengths and weaknesses.

Consultancy Firms (Large)		
7Safe, (PA Consulting)	Alvarez & Marsal	BDO
Deloitte	Ernst & Young	IBM
KPMG	PwC	
Consultancy Firms (Medium)		
AlixPartners	Ankura	Aon (Stroz Friedberg)
Blu Eye GmbH	Consilio	FRP Advisory
FTI Consulting	Grant Thornton UK	Innovative Development
Smith & Williamson		
Software Specific Organisations		
AccessData	ayfie	Brainspace
BundleDocs	Control Risks	Disco
edt	Everlaw	Exterro
Intelligent Voice	KLDiscovery	LitSavant
MedBrief	Netmaster (CaseLines)	Nuix/Ringtall
OpenText (Recommind)	Opus 2 International	Relativity
Servient	Veritas	Vound (Intella)
ZyLAB	Zylpha	
Solutions / Bureau Organisations		
Altlaw	Anexsys	CYFOR
Epiq	Hillogic	Inventus
Knovus	LDM Global	Legastat
Lighthouse	LINEAL	London Legal
Millnet Document Svcs	Morae Global	Sky Discovery
Special Counsel	TransPerfect	
Forensic Services		
Cellebrite	eMag Solutions	IT Group UK
Media Discovery		
Outsourcing Organisations / Document Review Firms / Translation		
BCL Legal	Cenza	Codex Global
Epiq	Exigent	Iconic Translation
i-Lit	Integreon	QuisLex

5.7 Software list

Following on from the principles used in the previous Section, shown overleaf is a list of the major software products available within the UK and the organisations that supply them. Again the headings used to group the products are an outline rather than hard and fast differentiations. The aim is to allow readers to identify what products are in a similar category so they are able (as much as possible) to compare like with like.

No endorsement is made or implied for any of these products and their capabilities do evolve relatively quickly, so contact the supplier(s) to find out more.

There are suppliers and products in the Guide which are not shown in these tables, this is because they do not have a UK office. However you might still use their services depending upon the geographic location of your project. The advice, as ever, is read Chapter 8 and evaluate each supplier's offering.

Chapter 5 – Market Survey

5.7.1 Software – By Supplier

Product	UK Supplier(s)
<i>Collection</i>	
Cellebrite	Aon, Cellebrite, CYFOR, Espion, FRP.
FTK	Access Data, A&M, Aon, CYFOR, FRP, IT Group.
Guidance EnCase	Aon, CCL Group, CYFOR, FRP, Integreon, IT Group.
<i>Processing and Early Case/Data Assessment</i>	
Digital Reef	TransPerfect Legal Solutions.
edt toolbox	eDiscovery Tools
ICE™	Consilio
In Control	Ankura.
Index Engines	Deloitte, Integreon.
Intella	7Safe, Aon, IT Group
IPro (eCapture)	Anexsys, Espion, Integreon, Legastat.
KOFAX Capture	Legastat.
Law PreDiscovery	AlixPartners, A&M, Ankura, Legastat.
MM/PC	eMag Solutions.
Nuix	7Safe, AlixPartners, Altlaw, A&M, Aon, Consilio, CYFOR, Deloitte, Espion, Epiq, Ernst & Young, Grant Thornton, Inventus, KPMG, Legastat, PwC.
Relativity Processor	Consilio
<i>Review & Analytic Tools</i>	
Concordance FYI	AlixPartners, Anexsys, Integreon, Legastat.
Relativity	7Safe, AlixPartners, Altlaw, A&M, Anexsys, Ankura, Aon, BDO, Consilio, CYFOR, Deloitte, DTI, Epiq, Ernst & Young, FRA, FRP, Grant Thornton, IDS-Legal, Integreon, Inventus, KLDISCOVERY, LDM Global, Lighthouse eDiscovery, LINEAL, London Legal, PwC, QuisLex, TransPerfect Legal Solutions
Ringtail	FTI Consulting, Grant Thornton, QuisLex.
Sightline	Consilio
Xera	Integreon
<i>"All in One Products" (Both ECA and Review)</i>	
AccessData	AccessData
cicayda	Legastat
Consilio Product Suite	Consilio
Deal Interactive	TransPerfect
DocuMatrix	Epiq Systems, QuisLex.
eTrium™	Control Risks
ediscovery.com Review	KrollDiscovery, QuisLex.
Exego	Planet Data
Exterro	Exterro
Integreon Tools	Integreon
Intelligent Voice	Anexsys, Ankura, BDO, Epiq, PwC
Recommind Suite	AlixPartners, Opentext.
Venio	Inventus
Veritas eDiscovery Platform	A&M, Ankura, CYFOR, Deloitte, Espion, Epiq, Ernst & Young, Grant Thornton, KPMG, LINEAL, Veritas.

Chapter 5 – Market Survey

Product	UK Supplier(s)
Viewpoint	LDM Global, QuisLex.
ZyLAB Systems	ZyLAB
<i>Digital Audio / Video Review Tools</i>	
Intelligent Voice	Anexsys, Ankura, BDO, Epiq, PwC
Nexidia	7Safe, Anexsys, CYFOR, Consilio, Deloitte, KPMG.
<i>Pre and trial room systems</i>	
BundleDocs	BundleDocs
CaseLines	Netmaster
ExhibitManager	Causasoft LLC
Magnum	Opus 2 International
TMX	Epiq
XBundle	XBundle
Zylpha	Zylpha Solutions

Chapter 5 – Market Survey

5.7.2 Software – By EDRM Function

The following table "maps" the different software offering to the areas of the EDRM model that they cover. This is not an exact science and you should check with vendors to obtain their viewpoint on where they sit and the facilities they offer.

Area	Software	
Collection	Cellebrite FTK SPEKTOR	Exterro Guidance EnCase UFED
Processing	Chat eDiscovery Digital Reef Index Engines IPRO eCapture Relativity Processor Kofax LAW MM/PC Nuix Proprietary Systems	AccessData Cicayda Consilio DocuMatrix ediscovery.com Review eTrium Exterro Integreon Tools Intella Intelligent Voice
Review/ Analysis	CaseLogistix Concordance Nalytics Relativity Ringtail Sightline	OpenText Accelerate Suite Veritas eDiscovery Platform Viewpoint ZyLAB Systems
Presentation	TMX PDF Bundling (e.g. Zylpha) ExhibitManager	Magnum CaseLines XBundle

5.8 Relativity "Plugins"

This is a Section introduced in the 2015 edition to showcase the increasing number of companies who provide additional software "plugins" for Relativity. The fact such a Section exists is testimony to the market domination being achieved by Relativity and their products.

What is this all about? In the words of Relativity;

"The Relativity Ecosystem includes best-in-breed integrations and highly customized products that were built by Relativity developer partners and the advice@kCura team. It allows users to pick and choose the solutions that best suit their unique workflows, integrating them to more easily and efficiently transfer data between software packages that serve different stages of the e-discovery process."

More details here:

<https://www.kcura.com/relativity/resources/ecosystem/>

The following product descriptions are taken from the various organisations' marketing material.

Product	Short Description
ayfie	
Inspector	ayfie Inspector is a powerful text analytics suite that lets customers find crucial information within their content. It goes beyond putting together patterns of words or similar names. It puts persons, locations, organizations and time into relation and connects dots that might have been missed otherwise. It presents its findings in a user-friendly interface with data visualizations that make multi-layered data relationships easier to see. It provides a modern way to cull down the massive data sets of today's litigations.
Anexsys	
RTK.ExcelRedact	Takes Excel documents of any shape and size and renders them as an interactive webpage which has been designed specifically for redacting Excel spreadsheets.
RTK.Redact	Enables you to redact a document, and with the click of a button seamlessly propagate these redactions across all instances of a document.
RTK.Message	Import data from social media sites such as Facebook to Relativity and review them in a user-friendly manner. Reviewers and administrators can quickly filter the message data to remove irrelevant content, and promote only potentially relevant data to the main document review.
RTK.Loadfile	Transport data in and out of review platforms and easily check for missing data. Users can compare a loadfile against a Relativity workspace to ensure no data is missing. It also splits loadfiles for faster ingestion and helps to comply with the requirements of a production or disclosure specification.

Chapter 5 – Market Survey

Product	Short Description
Consilio	
Advanced Visibility	Helps case administrators track case progress with real time data to effectively manage their projects
Search Magnifier	Automatically generates and runs multiple searches from the user's keywords and phrases. It turns a nine-step process into one simple step
XpressLook	XpressLook extracts raw files, de-duplicates, deNISTs and loads text and metadata into Relativity faster than other tools can ingest the data. It provides in-depth, multi-faceted data analysis, reporting and culling capabilities.
Intelligent Voice	
SmartTranscript™	<p>Converts an audio or video file into a SmartTranscript™, a Relativity-native, standalone HTML file containing:</p> <ul style="list-style-type: none"> • Searchable, navigable speaker separated transcript text • Embedded audio/video file with play, pause and horizontal scrub bar controls • A list of suggested topics of interest from the a/v file, which can be used to jump to the part or parts of the audio or video where that term occurs.
Lighthouse	
ChatSmart	ChatSmart enables the rapid, efficient, and complete review of chat data in many formats, from multiple sources.
PrivSmart	PrivSmart prioritizes first-pass privilege review and automates privilege log generation by categorizing documents into groups based on their likelihood of being privilege, as well as normalizing privilege log entries automatically.
RedactSmart	RedactSmart increases speed and consistency with which redactions are applied, using programmable pattern recognition to complete hundreds of redactions in minutes.
ReviewSmart	ReviewSmart optimizes review through the rapid and efficient disposition of duplicate documents that survive initial family-level deduplication.
LitSavant	
Conformity Engine	Enables any authorised user to design and implement rules which can be applied to the data entry process.
Miliyi	
Blackout	Blackout is an assisted redaction tool for Relativity. Streamline your redaction workflow and eliminate the time review attorneys spend applying redactions one-by-one. Simply select the criteria for redaction, the set of documents to review, and the redaction type, and Blackout does the tedious work for you.

Chapter 5 – Market Survey

Product	Short Description
Broadcast	Broadcast is a customizable reporting application within Relativity that lets you generate workspace-level dashboards where you can render important information via custom charts, graphs, and HTML for users without leaving Relativity.
Chronicle	Chronicle is the easiest way to build privilege logs in Relativity. With Chronicle create a consistent, defensible narrative while reducing the expense and time it takes to construct a privilege log.
Delegate	Delegate is the most robust admin tool for Relativity. Delegate allows Relativity hosts to create user and group level access settings for specific workspaces and matters—all within the same instance.
SFTS Engineering	
Illuminate	Illuminate extends the feature set of Relativity's document review and production capabilities.
Penumbra	Penumbra streamlines the redaction process when reviewing documents within your eDiscovery environment.
TSD Services	
MaxMessage	An enhanced messaging system across Relativity, giving you the ability to create and schedule messages to be sent instantly or during specific time periods to a specific user, group of users, all users in a workspace or all users in a Relativity instance. Also with the possibility of attaching files to these messages. In addition, you can keep track of message acknowledgment status (when and by whom the message has been seen, acknowledged or the attachments downloaded).
MaxBilling	An application that helps Relativity Hosting Partners and Relativity clients automate the process of customer billing within Relativity. Generate accurate and detailed, easy-to-read monthly reports with calculated costs from pre-set metrics and prices, including custom billing rates, periods, Tasks, Users and CaseRollup. By automatically generating bills, MaxBilling reduces the time and efforts you spent on billing, while minimizing the potential for errors.

6. PROCUREMENT APPROACH

This Chapter proposes a procurement approach that can be used in selecting vendors. It is anticipated that users might wish to cut and paste text from the chapter into their own documents so the word [CLIENT] has been used to enable a "find and replace" with firm specific details/name.

It provides an analysis of the types of pricing models suppliers might adopt, an overview of the procurement process, and then specific requirements for:

- Scanning.
- Unitisation and Coding Services.
- Data Collection.
- Litigation Support Services.
- Processing small volumes of ESI.



BEST PRACTICE: When should I involve a service provider?

As soon as possible in specific cases. Many law firms have been through procurement exercises and set up call off arrangements with a selected litigation support partner. They have an in-built advantage when it comes to eDisclosure.

6.1 Supplier's Pricing / Client Tactics

The purpose of this Section is provide an overview of the various factors that affect service providers' pricing so that the reader is better equipped to compare like for like. It is included in the Guide because this is a very difficult area, so be prepared for some work when you obtain quotations.

If the three most important things about buying a house are location, location, location, then the three most important factors about costing eDisclosure projects are volume, volume, volume. That is to say, ESI is notorious for becoming a black hole of ever increasing volumes, and as such it can be difficult to price the work. That being said there are some words of advice that can help.

6.1.1 Involve the supplier as soon as possible

The sooner a service provider knows what the project is about, the quicker they will be able to give you a price, and the more likely they are to be able to give you a more fixed cost. In an ideal world, readers will have selected a preferred supplier, (with a fall back in case of conflicts), familiarised themselves with the software and its capabilities, and have a call-off contract in place with a table of pricing. Failing that, you should at least have 2-3 known suppliers that you can call upon at short notice. If you telephone someone out the blue at 5 o'clock on a Friday afternoon and say you have 200 GB of data that you have to review by Monday, you will get a very different price than if you have pre-prepared the process.

6.1.2 Tell them as much as possible about the case

A good supplier will want to come and talk to you to explore all the aspects of the case; where the data is stored, what technical "gotcha's" might be lurking in the shadows, any obscure software or products that have known issues (Lotus Notes for example, is a favourite of corporates and has a lot of pitfalls for the unwary). The more they know about the task, the more they can advise you on the best way forwards and the more

flexibility they will have on pricing. Treat them as you would any technical expert. They have a deep range of knowledge, that you need on your side.

6.1.3 Understand the supplier's constraints

Service providers have three main components to their cost base, these are the costs of; storage, software and their professional services.

Storage in the UK is typically charged from between £30 - £50 per GB, per month. Some organisations rent their storage space, and thus are constrained on how much flexibility they have on pricing, others own their environment and thus have more room to manoeuvre. There are still some significant margins in this area, so be prepared to press hard on pricing here, but equally be prepared to divulge how much work you might be putting their way, what's the average size in ESI terms of your cases, how many litigation cases you do a year, and those kind of things. You do have that information at your fingertips don't you?

Suppliers that use third party software that they don't own, may have limited room to manoeuvre in terms of pricing. The original supplier of the software sets price boundaries beyond which third parties cannot move. Normally the more volume a bureau puts through a product, the cheaper it is for them, and thus they can pass on the price reductions. This is why it is advisable to run a procurement exercise and establish a call off contract before you find yourself making the Friday 5PM call.

Finally there will always be an element of professional services. The software tools need to be managed, and there is a need for some overall project management. Be aware that when a vendor provides project management, it will not include managing the project from your end (unless you are specifically paying for these services). That normally ends up the role of some hapless junior associate who spends more time being an ad hoc litigation support manager than they do practising law.

6.1.4 Don't keep asking for the "best of three" quotes

Some law firms have a policy of always getting a number of quotes beforehand and then showing the end client that they have got the "Best Price". This is very short sighted and no substitute for a proper procurement exercise. Suppliers get tired very quickly of being asked at short notice for a "quick quote", when they are only given half the facts, put in a lot of effort to provide a professional response, only to miss out on the work. Unsurprisingly they stop replying to law firms who operate in such a manner, meaning that you are limiting your procurement pool to the desperate and/or inexperienced suppliers.

6.1.5 Ask for flexibility in pricing

Once you have built a relationship with a supplier, then you can explore what flexibility they can provide in pricing. Just as the courts and clients are looking to pass risks on to the law firms, so you could be looking to pass some of that onto your litigation support partner. Note the deliberate use of the word partner. You cannot get a good price by ringing round the suppliers and seeing who will give you the cheapest quote for "processing 50 GB".

Service providers are well aware of the implications of the various legal reforms in this area, and should be looking to build relationships with you and give as firm a pricing as they can. The "worst" case should be a straight per GB price, but this is becoming increasingly rare. Vendors have a range of pricing plans they have on offer. Some will

not charge for the data going into the processing stage, only the material that emerges from the other end. Some will offer you a range of options for specific stages, and agree only to charge you the cheapest once the work is done and they can individually price what the components cost them. Some will ask for a retainer and then provide a fixed amount of capacity and processing for that price, which (if you are pushing the limits of the deal) can be good value.

The shorter version is that there are many ways to “skin this cat”, ask for them and then work out what suits you best.

6.1.6 Be prepared to do some work in comparing pricing

If the good news is that, there are many options for pricing, then the bad news is that, there are many options for pricing. You need to allocate some time and effort to getting the information and then putting it into a form so that you can compare like with like. It is not a simple matter of ringing three firms and asking them for their price to process 50 GB. You will tend to get three different sets of questions and then three different pricing models. If you haven't set up a preferred vendor arrangement, then the best way to proceed, might be to have an example requirement, that mirrors one of your cases, complete with all the background information and assumptions, then pass that to the vendors so that you can get an idea of their pricing. Be prepared to build and maintain a spreadsheet for this.

You will have sensed by now the common theme running through this section of involving service providers as early and as fully as possible in the case. Try to build a partnership with one of the many competent firms out there and (in the main) you won't go wrong. You will certainly be in a better position than those who don't bother and leave it to the last possible minute.

The rest of this Chapter takes you through how to procure suppliers and software.

6.2 Overall Requirement/Approach

A generic procurement exercise will typically go through the following stages :

- Requirements scoping.
- Match potential vendors to requirement.
- Assess vendor capability.
- Short list.
- Demonstration with real data.
- Establish call off contracts.

NOTE: How much do I really need to do?

As little or as much as you want. The aim is to end up with a preferred supplier, whether for one case or for many. Some law firms have followed a full procurement route taking weeks, others have asked 3 vendors in for demonstrations on one day and made a selection after that. The absolute minimum you must do is look at the software with the people who will support it, if you can use your own data for the demo, even better.

The main considerations for each of these stages are shown in the following sub sections.

6.2.1 Requirements scoping

All "Stakeholders" in the procurement should be interviewed. This not only includes the lawyers/legal staff in the litigation department, but might also embrace the legal teams from other disciplines. It should definitely include the IT department and (if one exists) the print room function. You would be amazed (or perhaps not if you are undertaking a procurement) as to how much stuff is still printed and photocopied.

The firm's accounting system might be examined to see which suppliers are already being paid for services, as well as a firm wide question on which suppliers people have heard about/used, and which they recommend/would never use again.

The aim of the exercise is to distil down the requirements of the various parties into a coherent whole, so that competing products can be assessed in an "apples" for "apples" manner.

One thing that will be needed is an estimate of the volumes of litigation that the firm undertakes. Firms should extract details from their Practice Management System on the number of new litigation matters created each month, and couple these with estimates on the number of "live" matters, a rough idea of how much each is worth, and how long the cases run for. In this way they will have some idea of the overall scope of their requirement, and also vendors will understand the approximate value of the work they might obtain, and can price their offering accordingly.

6.2.2 Match potential vendors to requirement

The aim here is to select a pool of potential vendors that match the requirement, with the trick being the elimination of those suppliers that do not "fit" the needs or ethos of the firm. This is a two way process, the vendors themselves are selective in their sales qualification process and will only focus on those prospects they have a real chance of winning. If your approach is too wide, you run the risk of alienating the marketplace, and only getting the desperate and the naïve bidding for your work.

6.2.3 Assess vendor capability

Assessing vendor capability can be done in a number of ways. More formal procurements go through a cycle of Request for Information (RFI) to gather market knowledge, followed by a much more detailed Request for Procurement (RFP), which would contain the types of requirements shown the following Sections.

Some firms prefer to go direct to a short list and straight into the formal RFP, whilst others will skip this stage entirely (with some advice) and invite a selected group in for demonstrations.

All approaches are valid, it depends upon the budget for the procurement exercise, the level of formality the firm requires and the scope of the requirements.

6.2.4 Short list

If a more formal RFP (and RFI) has been issued then the response will need to be evaluated, given some form of scoring (with or without weighting, depending upon the firm) and a short list selected. In cases where the circumstances warrant it, firms might move straight to this stage, relying upon their ability to identify which vendors might meet their requirements.

6.2.5 Demonstration with real data

The next stage is key. Firms must evaluate the software they are considering using by means of a demonstration, preferably using the firm's own data, ideally from a real life case, so that the issues with it are known. The panel looking at the products should be consistent across all demonstrations, and feedback should be collated in a managed format, so that personal bias is reduced as much as possible.

References might also be taken up at this stage. Ultimately, however, it is the interaction between end users, the software and (most importantly) the vendor's staff, that is of greatest significance.

6.2.6 Establish call off contracts

Once vendors have been selected, the call-off contracts with discounted rates should be negotiated. It is better to use the law firms contract as a starting point, though the vendor T&C's should be examined. The trap to avoid here is the over eager in-house lawyer looking to make up their hours who sees this as an exercise to re-write everything from scratch.

6.3 Scanning

This Section explores the requirements for scanning services, which are mainly commodity items, with some room for added value in terms of the approach to project management and unitisation.

6.3.1 Overall Considerations

It is expected that documents will mainly comprise single sided black and white A4 pages. There might be some colour pages, and document sizes other than A4. These are normally dealt with by an exception process.

The documents will normally be provided from [CLIENT] offices, though occasionally they might need to be collected from clients. The collection and transport of files/documents to and from the supplier will be the responsibility of the supplier.

It is proposed that the scanning work will be carried out at the supplier's site, however, it is the responsibility of the supplier to meet [CLIENT] security and document-tracking requirements in order for this option to be followed.

An optimal process needs to be identified which will ensure accurate document scanning including physical unitisation at a document level.

The documents to be scanned will normally be provided in banker's boxes. Within these boxes, the documents will be sub-divided into individual files that vary in size, type and binding.

6.3.2 Example Requirements

The activities to be completed by the selected provider are:

- Document / file preparation.
- Physical unitisation.
- Electronic scanning.
- 100% Quality control.
- Reassembly of documents / files.
- Objective coding and logical unitisation.
- Electronic BATES numbering – post scanning and quality control processing.
- Delivery of single-page tiff images with unitisation and coded information for loading into the litigation support environment.

In order to carry out these activities the provider will need to:

- Enter into a call-off contract with [CLIENT].
- Dedicate the required facilities at their site.
- Resource the required operations.

- Provide an experienced project manager to manage individual projects.
- Provide periodic reporting on project status.
- Manage the project budget to ensure costs are monitored and controlled.

6.3.3 Possible Quotation Format

Please provide pricing for the following items.

Scan, OCR and BATES number 100,000 pages. The pages are contained in 333 files, each file holding 300 pages, estimated 3 pages per document. If charged separately please show the cost of preparing the pages and then re-constituting the files, and the provision of logical unitisation information.

Please provide the cost for the provision of each of the services shown below. [CLIENT] have "weighted" these costs as an overall percentage of processing 100,000 pages to reflect their real life experience of the frequency of these requirements being needed. For example, roughly 15% of the pages encountered by [CLIENT] also need glasswork copying before they can be scanned, whilst other services occur at even smaller percentages.

The services are:

- Glasswork A4 B/W Scan
- Large Format Scan (i.e. A3 and above)
- A4 Colour Scan
- Glasswork A4 Colour Scan
- Large Format Scan Colour
- Re-Binds (Documents that have to be un-bound before they can be scanned and then reconstituted in a bound state)

Suppliers should also quote for the cost of providing load files, DVD and any project management / professional services surrounding the scanning.

If there are any other costs associated with the provision of scanning services, suppliers should show them in their completed quotations.

A potential layout for a quotation spreadsheet is shown below:

Chapter 6 – Procurement Approach

All prices exclude VAT		Vendor : Vendor Name			
Bidding for provision of these services : Yes / No					
Item/Activity	No	Unit	Unit Price	Total	Suppliers Comments
A4 B/W Scan	100,000	Pages		£0	
OCR	100,000	Pages		£0	
BATES Numbering	100,000	Pages		£0	
Physical Unitisation	33,333	Docs		£0	
File/Doc Handling	33,333	Docs		£0	
Glasswork A4 B/W Scan	15,000	Pages		£0	
Large Format Scan	20	Pages		£0	
A4 Colour Scan	5,000	Pages		£0	
Glasswork A4 Colour Scan	200	Pages		£0	
Large Format Scan Colour	40	Pages		£0	
Re-Binds	100	Docs		£0	
Load File Creation	10	Per File		£0	
DVD/CD	10	Per DVD		£0	
Technical Labour/PM	2	Days		£0	
					Spare for supplier use
					Spare for supplier use
					Spare for supplier use
			TOTAL :	£0	
Assumptions					
Pages / Document	3				
Pages / File	300				
Docs / File	100				
Total Docs	33,333				
Total Files	333				

6.4 Unitisation and Coding Services

The key consideration within this Section is the decision on whether to objective code ESI items or not.

6.4.1 Overall Considerations

There are advantages in using the firm that conducts the scanning to carry out the coding work, principally the overall control and cost saving that ensue.

The key to keeping prices down is to have the work carried out overseas. Most firms will offer a UK based service, but the cheaper rates come from shipping the work overseas. The service offerings do need to be explored, as some firms conduct their coding work in locations where the speed/quality of the internet connection is so poor, that the data needs to be transferred to that country for the coding work to be carried out. Other firms use organisations in countries where this is not an issue, and the data remains in the UK.

6.4.2 Example Requirements

[CLIENT] require a supplier who will provide objective coding for [both] paper documents [and ESI]. The supplier will provide the environment in which the coding takes place.

[CLIENT] will allow the data required for the objective coding process to reside in an overseas location.

For the paper documents, suppliers will receive physical unitisation information including attachment groups and will apply logical unitisation alongside objective coding

The following coding fields will be required:

Paper Documents

- Document Title.
- Document Type (taken from a list provided by [CLIENT]).
- Document Date (either taken from document or by deduction from context within the original file.).
- Estimated Date (Yes/No field, if Yes, supplier and [CLIENT] to agree convention used).
- Author.
- Recipient.
- Copyee.

Word efiles

- Document Title.
- Document Date (either taken from document or meta-data).
- Author.
- Recipient.
- Copyee.

Excel and PowerPoint efiles

- Document Title.
- Document Date (either taken from document or meta-data).

The Author / Recipient / Copyee fields for paper and efiles should show the name(s) and organisation(s) in brackets as shown below.

e.g. Andrew Haslam [Allvision Computing], Fred Smith [Client PLC].

A process of names normalisation will need to be carried out.

It is assumed that the document type data for all efiles will be provided as a bulk update in the export process, i.e. all Word efiles will have a document type of "Word".

In order to carry out these activities the provider will need to:

- Enter into a call-off contract with [CLIENT]
- Dedicate the required facilities at their site.
- Resource the required operations.
- Provide an experienced project manager to manage individual projects.
- Provide periodic reporting on project status.
- Manage the project budget to ensure costs are monitored and controlled.

6.5 Data Collection

The skills required to provide forensic services are very specialised, and take time to acquire. Therefore the firms operating in this area tend to be relatively small, even when the team itself is part of a large organisation such as the forensic groups of the big consultancy firms. It has been known for clients to form working relationships with specific individuals in the forensic world and remain "loyal" to that individual even when they change the organisation they work for.

6.5.1 Overall Considerations

There are two main types of data collection:

- Forensic services, such as imaging hard drives, copying data in a forensically sound manner (for example in fraud cases) or retrieval of deleted information.
- Data collection in accordance with the guidelines embodied in the Electronic Data Questionnaire.

6.5.2 Example Requirements

The services to be provided by the selected supplier should include:

- Forensically sound imaging of individual PC's, laptops, Apple Macs.
- Provision of a "data map" describing where the ESI is located throughout the client's IT infrastructure.
- Collection of selected ESI from client's infrastructure.
- Remote collection of selected ESI for overseas clients either by hardware or software based solutions.
- Sound knowledge of the data protection requirements in various countries.
- Support to [CLIENT] in exploring the collection of ESI from external devices such as pen drives, mobile phones, external hard drives, etc.
- Support to [CLIENT] in exploring the possible collection of ESI from on-line applications such as email systems or social networking software.
- Processing of back-up tapes.

In order to carry out these activities the provider will need to:

- Enter into a call-off contract with [CLIENT]
- Dedicate the required facilities at their site.
- Resource the required operations.
- Provide an experienced project manager to manage individual projects.
- Provide periodic reporting on project status.
- Manage the project budget to ensure costs are monitored and controlled.

6.6 Litigation Support Services

This Section is the main focus of the Guide and contains a significant amount of detail.

6.6.1 Overall Considerations

The following list of requirements is an extensive one. It is intended that users of this Guide will select those requirements that meet their needs and shape their procurement accordingly. The initial approach should be to determine what tools are available within the marketplace, and what their functionality might be. Vendors should not be disqualified from the selection process if they cannot supply some of the more advanced requirements, indeed users might not have need of that functionality for some time to come.

6.6.2 Example Requirements

The services to be provided by the selected supplier include:

- Provision of processing facilities to enable de-duplication and filtering of data.
- Processing of Outlook, Lotus Notes and GroupWise email files.
- Any visualisation of the connections between data custodians.
- Processing, display and review of family groups of ESI files.
- Processing, display and review of scanned and coded documents.
- Ability to display information across dual screens.
- Provision of OCR from imported image files.
- Ability to store, display, search and review PDF files.
- Handling of foreign language based ESI.
- Near-duplication.
- Concept clustering / searching.
- Any other analytics functionality.
- Email threading.
- Predictive / Technology Assisted / Computer Assisted coding.
- Handling of digital audio files.
- Automatic translation of foreign language ESI.
- Provision of objective and subjective coding (including issue/hot topic) fields.
- Full search capabilities, including Boolean logic, saved searches and dynamic search update.
- Disclosure production capabilities, including BATES numbering, production of Privilege and Trade Secret lists, mass burning to external media.

- Production of a courtroom bundle.
- Strategy for meeting the demands of "tablet" based computing.

In order to carry out these activities the provider will need to:

- Enter into a call-off contract with [CLIENT].
- Dedicate the required facilities at their site.
- Resource the required operations.
- Provide an experienced project manager to manage individual projects.
- Provide periodic reporting on project status.
- Manage the project budget to ensure costs are monitored and controlled.

6.7 Processing small volumes of ESI

Most firms have a need to "just read the emails" and this Section attempts to articulate that requirement.

6.7.1 Overall Considerations

A requirement has been identified to provide a mechanism whereby users in the firm can review relatively small amounts of electronic information. A classic scenario, is that a client will ask for an evaluation of a potential matter, often on the assumption, that they will either not be charged for this initial evaluation, or it will be a nominal fee. This need is not limited to the litigators in a firm, most lawyers/legal staff receive information in an electronic form and wish to quickly examine it. The issue is that it is difficult, if not impossible, to put this data into the firms in-house systems, as the IT department actively discourages ephemeral client data being added into the sanitised, backed-up, secure environment they provide for the lawyer's use.

The broad outline of the proposed approach is as follows:

- Vendors provide a solution with specific boundaries in terms of size of data, number of users and timeframe with a low price attached. For example, up to 500 MB of data, with one person looking at it, for one month at £50-100/month up to a maximum of 3 months.
- There is some form of easy to use mechanism whereby the Client information, PST file, email attachments, USB stick can be securely transferred to the vendor.
- The vendor loads the data into their litigation support environment without any additional processing and stores it under a client/matter reference.

6.7.2 Example Requirements

The services to be provided by the selected supplier will include:

- Provision of means to securely transfer the data between [CLIENT] and the supplier, probably using a secure file transfer mechanism known as "secure FTP".
- Loading of email and electronic files into the selected product in a speedy manner, (the aim will be an overnight service).
- Provision of tools to allow the initial reading and analysis of documents.
- Provision of review tools to meet the needs of a "quick peek" scenario.
- A well-defined route to export the data so that it can be processed and loaded into the "full blown" litigation support tool.

- Very competitive pricing.

In order to carry out these activities the provider will need to:

- Enter into a call-off contract with [CLIENT]
- Dedicate the required facilities at their site.
- Resource the required operations.
- Provide an experienced project manager to manage individual projects.
- Provide periodic reporting on project status.
- Manage the project budget to ensure costs are monitored and controlled.

6.8 Schematic of Generic Requirements

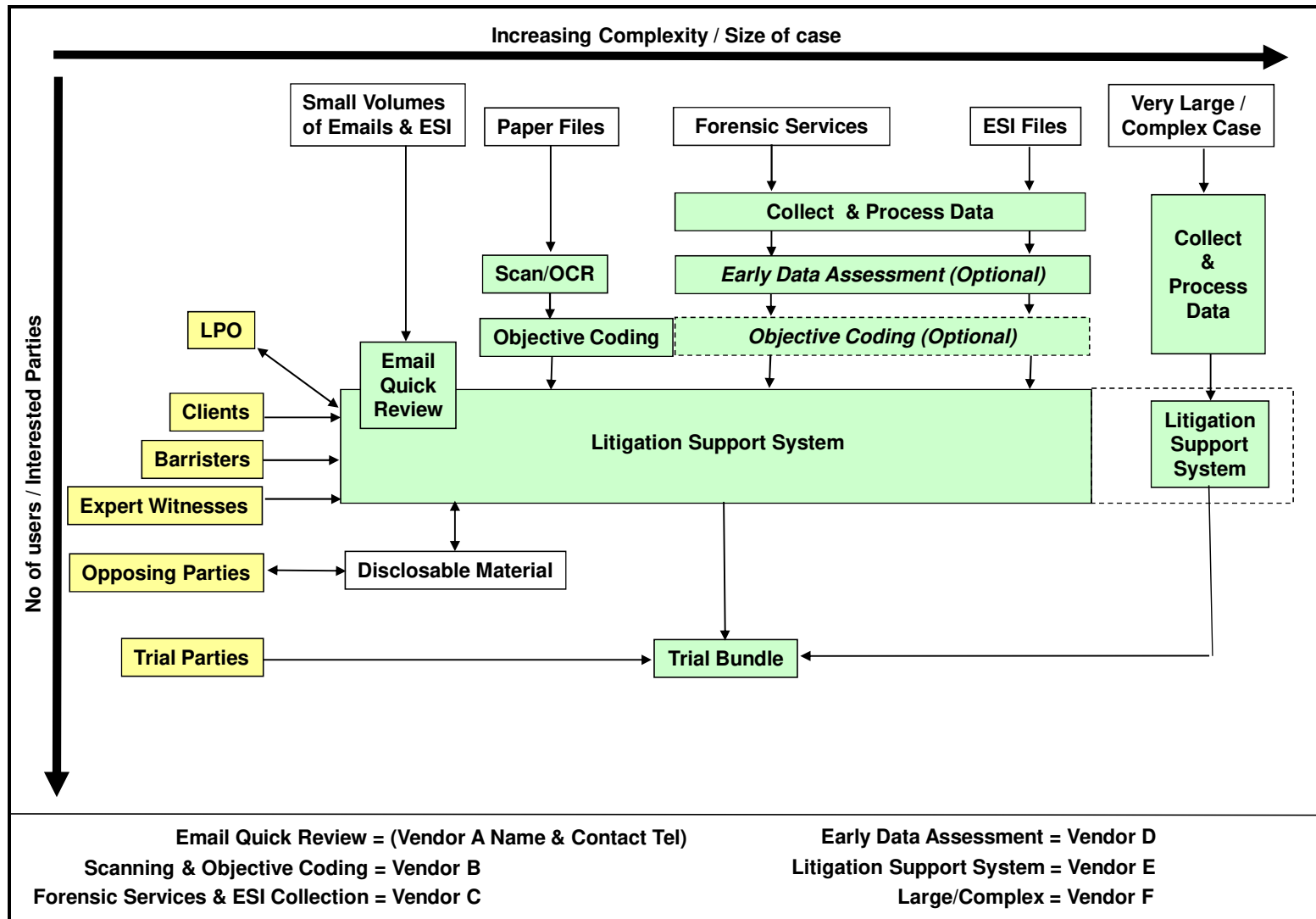

6.9 Summary

This Chapter has provided users with the information for them to undertake a procurement exercise. As with all such exercises, the key to a successful project is a clear understanding of what the requirements are, and how best they might be met. Various potential requirements are shown, so that a selection can be made of the ones that best meet the user's needs. Once that framework is in place, and a shortlist of potential suppliers identified, then the proposed software solutions must be evaluated by means of a demonstration to a representative panel, preferably using the firm's own data.

7. ADDITIONAL RESOURCES

This Chapter provides a list of additional resources for users to refer to. It is not exhaustive and feedback on any additions is welcomed.

7.1 Legal IT Insider

The Legal IT Insider is the leading media, information and communications organisation in legal IT. More details here:

<http://www.legaltechnology.com/>

7.2 The e-Disclosure Information Project

The [e-Disclosure Information Project](#) is run by Chris Dale, a former commercial litigation partner turned e-Disclosure consultant. The Project aims to bring together lawyers, suppliers, courts and corporations with an interest in electronic disclosure, and to disseminate information about the court rules, the problems and the software and services available to handle them. It has an excellent resources section [here](#).

7.3 The BONG! Emails (Jonathan Maas)

Jonathan Maas from Maas Consulting provides, in his words, an "informal, occasional and personal selection of recent international eDisclosure/eDiscovery/legal IT/data protection/interesting news/articles" via his BONG! emails (named after the headlines on the main evening TV news in the UK, on which headlines are read out between strikes (bongs) of Big Ben). To find out more, or to subscribe, please contact Jonathan on Jonathan@MaasConsultingGroup.com.

7.4 Clive Freedman (eDisclosure web site)

Clive Freedman maintains a website relating to electronic disclosure (mainly from an English perspective).

Clive is a Barrister of 3 Verulam Buildings, Gray's Inn, London, England. He was a member of the Working Party chaired by Senior Master Whitaker which was set up by the Civil Procedure Rule Committee, and which prepared drafts of Civil Procedure Rules Practice Direction 31B and the Electronic Documents Questionnaire. He also contributed to the TeCSA eDisclosure Protocol for use in the TCC.

The website can be found [here](#). Note that from September 2018 onwards this became a static resource and is not being updated as Clive is focusing on his GDPR website.

7.5 Civil Evidence for Practitioners

The fourth edition of "Civil Evidence for Practitioners" written by Professor Peter Hibbert, published by Sweet & Maxwell, is now out, with chapters in eDisclosure making significant use of the TCC protocol and its supporting material, find it [here](#).

7.6 Electronic Disclosure – Law and Practice

This [book](#) by Michael Wheeler and Charles Raffin from Hardwicke Chambers provides exactly what it says in the title. Though a pilot of proposed changes to CPR will take place in 2019/20, there is much still in this book to warrant a read. In their own words:

- A detailed guide to the complex issues surrounding eDisclosure presented in an accessible and user-friendly format
- The first work of its kind to offer comprehensive analysis of the developing law on electronic disclosure combined with practical advice focusing on electronic disclosure and related document production in practice; a complex and fast-growing area of evidence gathering and review

- A fully up to date examination of the relevant procedural guidelines and case-law in this area

7.7 The 2018 eDiscovery Buyers Guide (US Focus)

In their own words:

“Legal technology professionals Brett Burney and Chelsey Lambert have released the 2018 [eDiscovery Buyers Guide](#) - a shopper's handbook and educational resource for solo to mid-sized law firms. The Guide was designed to serve as a shopper's handbook for solo to mid-sized law firms in search of options that fit their budget and average case size. Free to download, the e-book is divided into the primary product and service categories seen in the litigation support process which includes hosted solutions, SaaS platforms, social media evidence capture, service providers, utilities and more.

7.8 The TCC eDisclosure Protocol

During 2013, the author was part of a Working Group charged with producing an eDisclosure protocol for use within the Technology and Construction Court. The protocol pack, and all the materials used in the training about the approach, can be found at the link shown below.

<http://www.tecsa.org.uk/e-disclosure>

The timeline from the pack is shown overleaf and overlays the legal process with the EDRM model.

7.9 The ILTA eDisclosure data exchange Protocol

During 2018/19 the author was part of a working group from the UK ILTA litigation support Special Interest Group (SIG) that produced a best practice data exchange protocol and associated guidelines. The driving reason for this project was the fact that the previously mentioned disclosure pilot as set out in [Practice Direction 51U](#), now in force in many UK civil courts, requires completion of a Disclosure Review Document. Among other things, the DRD requires parties to agree how they will transfer information between them in the disclosure process.

The matters to be agreed are set out in Section 3 of [Appendix 2](#) to the Practice Direction, and specifically in paragraphs 6 (7) – (11). The aim of the ILTA protocol is to address those requirements and provide information and education on the factors to be considered in the guidelines.

The protocol incorporates feedback from a number of eDisclosure suppliers and is endorsed by many more, as well as being used by various law firms. You can see all those involved in the project and download the documents from the ILTA [website](#).

7.10 The TCC Legal/EDRM Timeline

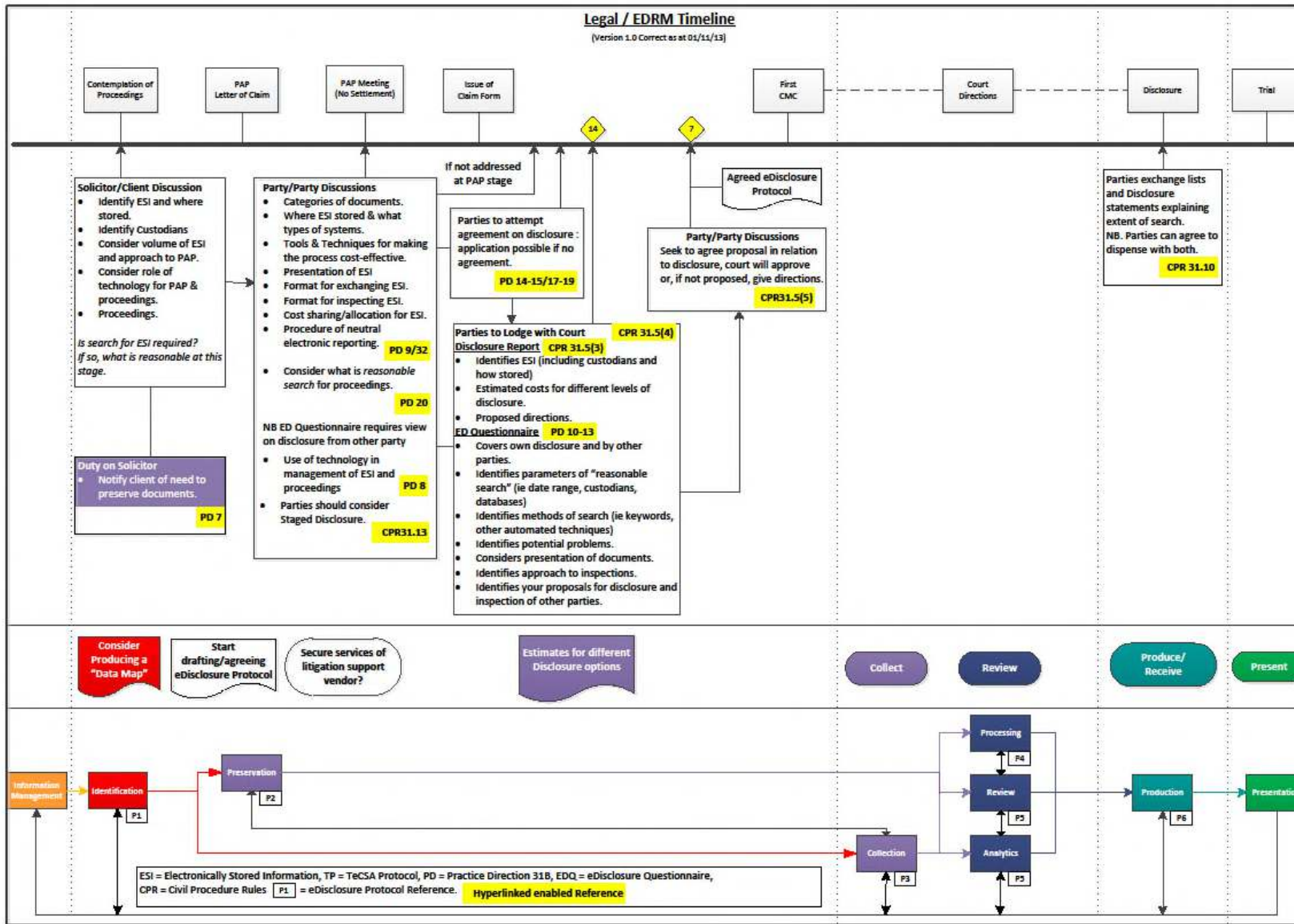

Chapter 7 – Additional Resources

This page intentionally left blank.

8. SUPPLIER & SOFTWARE DETAILS

This Chapter contains information provided by suppliers, albeit moderated by Andrew Haslam. See Annex B for the form used to provide feedback. Any omissions or corrections will be addressed in the next version of the Guide, please send material to Andrew in a Word format at:

andrew.haslam@allvision.co.uk

The information is in alphabetical order.

Suppliers have been asked to provide the following:

- A brief (half a page maximum) synoptic description of themselves and their services.
- A listing of the software they use.
- A brief (half a page maximum) synoptic description of the software they provide.
- Contact details for anyone to approach them.

In the interests of brevity, the information is split into suppliers and software, with the software each supplier uses, merely listed in the supplier section, and a fuller description given in the software part of the Chapter. For example a number of vendors use the software package Relativity. This is described once in the software Section, and mentioned a number of times in the various supplier's descriptions.

8.1 Suppliers

The following pages show information provided by suppliers. It is mainly UK based, but some organisations from other jurisdictions have asked to be included, so are within the pages.

8.1.1 7Safe, a PA Group Company

Abby Muir	 
abigail.muir@paconsulting.com	
01763 285 026 / 07979 703096	
10 Bressenden Place, London SW1E 5DN	
www.7Safe.com	<p><u>Company Description</u></p> <p>7Safe provides configurable, cost effective eDiscovery, cyber incident response and digital forensic services to law firms and General Counsel. We were founded in 2002 and acquired by the global Management Consultancy, PA Consulting Group, in 2011.</p> <p>Our approach to eDiscovery is unique</p> <p>7Safe will always:</p> <ul style="list-style-type: none"> • ensure that you find our eDiscovery services simple to use • provide you with clear quotes for any eDiscovery matter • use our technical forensic skills during the collection, preservation and processing of data • accept complex challenges where innovation & adaptability are necessary to manage the risk and cost <p>We have many years of experience in providing eDiscovery solutions</p> <p>7Safe uses a distinctive blend of highly-experienced digital forensics, IT infrastructure and information management professionals to continually refine and deliver our eDiscovery services. This ensures that our clients have access to the latest thinking and technologies to support their eDiscovery and legal needs. A popular service for new clients includes:</p> <p>Assisted DSARs: Our quick-to-use and fixed-price, data subject access request service is an easy way for you to comply within 30 days to any size DSAR. Our experts have the understanding to guide you on how to best manage the request, and data is provided to us through our secure online portal removing the need for you to handle, prepare and host the data on your own systems.</p> <p>Clients use 7Safe to help manage and control their global information challenges for litigation, regulation, investigation and arbitration matters. We are qualified experts in ensuring that electronic information is optimised for your investigation. Information Security is also now of paramount importance; 7Safe is one of the only firms that specialises in this field and makes us suitably placed to advise on, control and to protect your data.</p> <p>We are also an approved supplier on the Crown Commercial Services eDisclosure services framework open to all public sector customers.</p> <p>http://ccs-agreements.cabinetoffice.gov.uk/contracts/rm3717</p> <p>7Safe’s eDiscovery services will provide you with confidence</p> <p>Our services all offer:</p> <ul style="list-style-type: none"> • Transparency – clients knowing why we are doing what we are doing • Visibility – clients see what we are doing at all times • Shared Commercial Risk – 7Safe appreciates and understands the complexities of eDiscovery and are willing to share the risk with our clients.

We share knowledge & expertise at all stages of the disclosure process

Our people are all experienced in bridging the communication gap between legal, IT, project managers and other stakeholders. They are fully conversant with the end-to-end processes and the pitfalls of complex projects including legal holds, dealing with custodians for data collections, processing, document review, predictive coding and production. We use methods developed in the computer forensics industry to ensure that your matter is legally defensible from start to finish.

Vendor Offerings

Our eDiscovery services are always individually configured for each specific client matter

We use the best technology in the most appropriate way. Technology alone is not the answer, which is why we always work closely with you to ensure the technology is matched to the goals, resources and methods of each project:

- **the most suited technology** – we regularly review the market for the latest technologies to ensure we are offering the best functional and commercially viable applications. This process has kept us committed to Nuix (processing) and Relativity (document review and predictive coding).
- **information handling expertise always on hand** – all our consultants are all information engineers who will manage and operate all elements of your matter from start to finish. This ensures continuity and detailed understanding of the case so as to remove any delays or service hold-ups. Our lead eDiscovery consultants are qualified Relativity Certified Administrators (RCA).
- **focused outcomes & delivery management** - irrespective of technology or technical skill, service remains the core of our trading ability, reputation and our industry standing. 7Safe's blend of investing in project delivery to achieve a great outcome is the very heart of what we stand for.

7Safe eDiscovery services

7Safe provides a premium end-to-end eDiscovery service, including:

- **Preservation & Collection** – 7Safe is proud to have partnered with the former ACPO E-Crime Working Group and Metropolitan Police Service in the authoring and publication of the Good Practice Guide for Digital Evidence. (<https://www.7safe.com/research-and-insight/acpo-guidelines>) and retains very advanced digital forensics skills. We are skilled at collecting and preserving data from all unusual devices through to retrieving backups from the “cloud”
- **Early Case Assessment** – in close collaboration with our clients, we focus a combination of price, speed and intelligence into generating early case visibility using our own unique tools and processes to provide early focus and help in the early stages of a case. This includes our social media intelligence capability which provides commercial insight and market intelligence extremely quickly
- **Processing** – our focus always is the price point and speed selection balance. Our Nuix data processing capability runs at industry leading speed, therefore giving you high quality results can be achieved fast and at minimal cost. If time is not an issue, then we have more cost effective solutions for dispute teams working to tight budgets
- **Technology Assisted Review** - we configure our workflow processes and algorithms together with you to best suit your matter and achieve the very best outcome using such predictive technologies
- **Document Review Platform** - a secure, fast, enterprise Relativity platform designed to support many thousands of users

- **Air-Gapped, On-Site Solutions** – when legislative or privacy matters drive the specific location of data, we can deploy solutions to ensure total control over where data is processed and reviewed.

Cyber Incident Response, Digital forensics and investigations

7Safe also has a leading cyber incident response and digital forensics team who can help you with cyber incidents together with digital forensic investigations. Services include:

- **Cyber Security Incident Response* and Threat Hunting (*CREST Accredited)**
- **Digital forensic analysis and investigation**
- **Forensic data collection**
- **Evidential reports and expert witness services**
- **Incident response and forensic capability development**

Security Assurance and Testing

Underpinning all of the above, is our absolute **focus on Information Security**. We are ISO27001 certified and members of Institute of Information Security Professionals (IISP)

Training and Professional Development

We also provide industry recognised technical training courses that have been accredited by both CREST and IISP. (<https://www.7safe.com/professional-development>)

Information Management Advice

Together, 7Safe and PA have a long established record of helping large global organisations organise their information better. A core part of our work with our clients is to help keep the cost of future eDiscovery down, as well as implementing workable records management policies, processes and IT to reduce exposure to litigation and regulatory penalties by advising on:

- European General Data Protection Regulation (GDPR)
- Information governance & architecture
- Records management, including Legal Hold processes
- Data retention & protection.

8.1.2 AccessData (US)

Lori Tyler, Vice President of Global Marketing	
ltyler@accessdata.com +1 480 361 3513	
588 West 400 South, Suite 350, Lindon, UT 84042, USA	
www.accessdata.com	
<p><u>Company Description</u></p> <p>Whether it's for investigation, litigation or compliance, AccessData® offers industry-leading solutions that put the power of forensics in your hands. For more than 30 years, AccessData has worked with more than 130,000 customers in law enforcement, government agencies, corporations and law firms around the world, providing both stand-alone and enterprise-class solutions that can synergistically work together. The company is backed by Sorenson Capital, a leading private equity firm focused on high-growth portfolios. For more information on AccessData, please go to www.accessdata.com.</p>	
<p><u>Vendor Offerings</u></p> <p>AccessData is a digital forensics software company, serving the global public sector markets, corporations, law firms and service providers for the purposes of investigations, e-discovery, legal review, post breach analysis and compliance.</p> <p>CORPORATIONS</p> <p>Today's corporations are dealing with enormous amounts of digital data, all being shared among teams, departments, global locations, and devices. Even in industries as varied as healthcare to finance to energy, enterprises need to manage digital investigations, cyber risk and e-discovery faster, more efficiently and more securely, while reducing cost. Additionally, it's critical to have a global view while applying standards to data activity. Varying data privacy regulations, as well as regional risks and communication practices, must all be taken into consideration to ensure data security and improved efficiency. Finding tools to help you create the appropriate balance between collecting relevant evidence for investigations and maintaining privacy rights should be priority number one.</p> <p>PUBLIC SECTOR</p> <p>Along with the perennial challenge of cash-strapped budgets, public sector organizations today are grappling with increased backlog from growing, more complex caseloads. More than ever, it's critical that teams can zero in on relevant evidence fast, and build cases to fight fraud and other crimes endemic to government and the public sector. What's needed are tools to locate and analyze data often unavailable through conventional processes, allowing examiners and investigators to collect key evidence quickly and with confidence.</p> <p>LAW FIRMS</p> <p>More and more, law firms want to better serve their clients by simplifying their e-discovery processes and reducing costs. This can be a tough challenge with today's caseloads where millions of documents and terabytes of data are commonplace. To make e-discovery more efficient, you need access to integrated tools for processing, review, and case organization. And you need a real-time review platform that allows secure collaboration, regardless of where any member of the litigation team is located.</p> <p>SERVICE PROVIDERS</p> <p>Multinational service providers, consultants, and accounting organizations have unique business challenges that cut across the corporate and legal world. Like law firms, service providers need to be able to carry out complex e-discovery projects. They're also expected to provide expert support for international compliance efforts.</p>	

Chapter 8 – Supplier & Software Details

As such, there's an urgent need for tools that can support globally dispersed investigatory teams and real-time collaboration. And as with large enterprises, service providers need to balance evidence collection and privacy rights.

8.1.3 AlixPartners

Becky James	
rjames@alixpartners.com +44 207 332 5051	
6 New Street Square, London EC4A 3BF	
www.alixpartners.com	
<p><u>Company Description</u></p> <p>AlixPartners is a global advisory firm with approximately 2,500 consultants in 30 locations world-wide. Founded in 1981, AlixPartners advises global firms facing high-risk disputes and investigations, as well challenging situations in the context of corporate restructurings and operational improvement.</p> <p>Our Legal Technology team includes over 100 consultants in various cities in the United States, the United Kingdom, Germany, Buenos Aires, Tokyo, Seoul, Hong Kong, and Shanghai. Our team collaborates across regions, delivering forensic accounting, valuation, and information management services. We also provide expert services on matters ranging from cyber security to competition economics. Many our team have testified as expert witnesses.</p> <p>Our e-discovery practice follows the firm’s overall approach by optimising our capabilities for high-profile matters with cross-border scope. Our global team follows standardised procedures to reduce risk and deliver consistently across the globe. Having grown organically since the founding of our practice in 2002, AlixPartners merged with Evidence Exchange in 2015, and added a development team based in Argentina, increasing our capacity to over 100 consultants focused on e-discovery, legal technology and computer forensics.</p> <p>Our growth is premised on the following principles:</p> <ul style="list-style-type: none"> (a) Screening our consultants equally on their expertise and commitment to building a highly effective team; (b) A service delivery culture that emphasises accuracy, responsiveness, and accountability; (c) Investment in a high-performance data management infrastructure; (d) Deploying leading software platforms; and (e) Developing software where the market does not offer suitable solutions. 	
<p><u>Vendor Offerings</u></p> <p>Overview</p> <p>AlixPartners’ Legal Technology team advises clients on every aspect of data management in litigation and investigations including: information governance, data preservation, forensic analysis, data collection, data processing, database hosting, disclosure management, and claims management.</p> <p>Additionally, we provide secure data rooms for corporate mergers, acquisition, divestitures, and reorganisations.</p> <p>Discovery Management</p> <p>With respect to electronic disclosure, we advise legal teams to help them make sound decisions about the various aspects of data management and review. For example, we provide forecasts, detailed cost estimates, and tracking of expenditures against budget on a weekly basis.</p>	

Using a combination of custom reporting, early case assessment, technology assisted review, and other means as appropriate, we encourage legal teams to leverage text analytics to safely accelerate review, whilst reducing overall cost. At the end of the disclosure process, these tools are equally valuable to validate disclosure sets and avoid inadvertent disclosures.

In relation to structured data, our approach is driven by our expertise in analytics, which emphasizes the following capabilities:

- (a) Advise clients on the means to extract data from corporate systems such as mainframes, SAP or Oracle, as well as proprietary databases;
- (b) Identify relationships between data sets, including structured and unstructured data sources, and consolidate related information into a single platform;
- (c) Assess the means to visualise information so that the investigation team can directly query and interact with complex data sets.

Software

We continually evaluate technology platforms to determine which can improve our ability to deliver for our clients. Currently we offer Relativity for document management and Brainspace for analytics and predictive coding. For data processing we use Mindseye, Nuix, and Relativity.

Where we identify a gap in the software market we develop our own platforms, which in recent years has been focused on data assurance and analytics functions. We also offer a variety of options for machine translation services.

Document review

When needed we can assist law firms and corporate counsel with the provision of review teams, blending paralegals, qualified lawyers, and forensic accountants to conduct thorough investigations. In most cases the cost of such reviews is mitigated by the extensive use of predictive analytics.

8.1.4 Altlaw

Adam Page	
adam.page@altlaw.co.uk 020 7490 1646	
Angel Wharf, 54 Eagle Wharf Road, London, N1 7ER	
www.altlaw.co.uk	
<p><u>Company Description</u></p> <p>Founded over a decade ago, Altlaw provides technological expertise in electronic litigation support and legal document services and has become a recognised leader in the eDisclosure market. A personable and highly experienced team, we offer specialised products and services, coupled with proven procedures and techniques.</p> <p>With many years' experience of working with law firms and in-house counsel, Altlaw dramatically speeds up the process of identifying, reviewing and managing relevant data files.</p> <p>Our focus is to perfect techniques and processes which allow our clients to make better informed decisions at the earliest possible point in the litigation procedure.</p> <p>Altlaw works with all sizes of law firm, ranging from boutique litigation firms to silver circle, magic circle and international firms. Working comfortably across litigation, regulatory, investigatory and compliance matters, we have a particular experience with large construction cases and have worked closely with the leading firms in this area.</p> <p>With highly customisable, rapidly scalable solutions, Altlaw also has extensive experience with managing the international needs of its clients, having completed more than 65 different jobs with an international dimension, ranging from on the ground forensic collections through to international on-site hardcopy processing.</p> <p>Client references are available upon request.</p>	
<p><u>Vendor Offerings</u></p> <p>Offering a range of services, across the full spectrum of the EDRM, Altlaw is a highly capable organisation, able to provide a bespoke solution depending on your specific needs. With a dedicated project manager available throughout the project life cycle we offer:</p> <p><u>The Initial Stages</u></p> <p>As part of Altlaw's offering, before taking instruction on a matter, we undertake a data mapping and scoping exercise in order to ascertain the location and volume of any potential relevant data. We offer this service free of charge and find that these initial discussions are hugely effective in ensuring the smooth progression of a project as well as enabling accurate cost estimates. This key stage commences the defensible process that we apply to all elements of our service.</p> <p>In addition, to these early mapping exercises, we are regularly faced with projects that have a high volume of initial data that result in only a small percentage of responsive data. In order to effectively cull the irrelevant data prior to the review stage, the Altlaw team place a high importance on the key word testing process. Time spent at this stage proves invaluable and results in a more cost and time efficient review once the data has been transferred to any of our various review platforms.</p>	

Forensic Collection & Investigation

Often key data is hidden, intentionally destroyed or password protected. To ensure all evidence is subject to a litigation review, Altlaw's computer forensics investigators can quickly build cases based on custodial data, revealing off-site email, portable storage usage or user-created passwords.

Early Case Assessment using Nuix

Altlaw's Early Case Assessment (ECA) tool is a powerful platform that dramatically reduces the time it takes to process vast volumes of data. Altlaw are capable of processing up to a terabyte of data per day. Altlaw also offers its 'light touch eDiscovery' service. This service, using light touch metadata scanning technology, allows you to take a quick and efficient look at your dataset, providing you with a faster, leaner, more accurate method of estimating costs and does so in a way that minimises pre-processing costs.

Document Review

iConect Xera

This provides an end to end eDiscovery solution, encompassing processing, analytics, and Technology Assisted Review in a modern, user friendly, intuitive interface.

With 24/7 SelfServe the Client is able to 'drag and drop' Data and make it available for immediate review without the need for external provider interaction.

The platform allows for customised branding and 'white-labelling', as well as accessing case statics on mobile devices via the iCONNECT mobile app.

Relativity

Altlaw's also provides Relativity to make the entire document review process easy to manage, and gives you full control over everyone in the review team. Hosted in our fully virtualised and secure London data centre, it's a web-based review platform that can be accessed from anywhere in the world. This allows you to:

- Search, review and organise the documents to rapidly identify whether or not a document is relevant
- Manage everyone in the review team easily and effectively
- Automatically allocate files to the different levels of the review team
- Control which files team members have access to
- Save valuable time and money in online review time
- Full production capability, including converting to TIFF, redacting and bates stamping
- Automated disclosure list creation

Altlaw Mobile:

Altlaw is now able to offer a complete non-cloud based, physical Mobile client site processing and hosting solution, which can overcome many of the obstacles and challenges of Cross Border Data Protection laws. The solution can act as a stand-alone closed network in a totally secure environment, or can be integrated behind the firewall, with the client controlling all aspects of security.

With the increasing number of Cross Border, multi jurisdiction Litigations and Investigations taking place, particularly in the EU, this approach offers an innovative solution to many of the problems of Cross Border Data Protection Laws.

The tool is also proving useful in the UK and Channel Islands, where client confidentiality is a major stumbling block for regular online, hosted review.

Under normal circumstances, Altlaw are able to install our mobile servers, and have them ready to receive data, anywhere in the EU, or indeed globally within 72 hours.

Features of Altlaw Mobile:

- Scalable
- Full End-to-End solution from data processing to disclosure production.
- Minimal training required
- Supports multiple review teams
- Full disclosure productions

Altlaw Managed Review

Altlaw Managed Review is a UK based solution for document intensive review from our secure premises in London where we have over 80 seats. Our level of involvement can be tailored to your needs allowing you to create greater efficiencies in the eDiscovery process. We eliminate the time, effort and cost of recruiting, training or retraining your staff.

Crucially, Altlaw Managed Review allows your legal team to focus on their core high-value case work, while we manage and reduce the time-consuming and costly process of first pass document review for litigation, regulatory investigation and compliance matters.

Altlaw Managed Review will:

- Provides secure document review workspace
- Allows our clients to scale up their legal team to be able undertake larger matters
- Provide predictable and proportionate cost models
- Provide and manage review teams of experienced solicitors and paralegals
- Assist with creating matter-specific review manuals respecting the principals of Practice Direction 31B and the CPR
- Automate workflow and implement quality assurance check points
- Produce timely progress reports and metrics
- Provide a fluid body of responsive e-documents capable of being arranged and grouped by each document's proper context to enhance your detailed case review

Our managed review service will deliver a streamlined cost effective and proportionate high-quality document review solution so that you and your team can focus on the substantive issues of the day. No matter the size or scope of the project, our experienced team will deliver a successful result on time, on budget, every time.

Electronic Data Disclosure

All data is processed in the most efficient and intelligent way possible and a detailed audit trail is produced to ensure legal compliance. Everything is assigned a unique identifier – separating items such as emails and their attachments, while still maintaining a record of these relationships. The Chain of Custody is upheld throughout. Filters can be run based on dates and keywords. All the metadata remains intact, so there is no data spoliation. The data can be exported in different

formats, compatible with all major review platforms. We have produced data for the Department of Justice and the Securities and Exchange Commission amongst others.

Hardcopy and Document Production

Photocopying: Capable of huge volumes, our print room comprises of fast, networked high volume machines as well as smaller digital machines that are ideal for complex glasswork type jobs.

Scanning: Altlaw offers fully integrated scanning and image capture solutions. We are able to capture any size of document, from a business card up to 60” large format of virtually unlimited length or volume, in either b/w or full colour.

E-Bibles: Altlaw is able to produce a bespoke Electronic Transaction Bible based upon the universally used Adobe Acrobat format. We are able to incorporate both scanned images and supplied electronic formats.

Experience

By way of example, this includes:

- Completing a multi-terabyte data collection project by dispatching forensic data collection specialists to the [Channel Islands via private aircraft](#). This enabled analysis and processing of the data to commence on the same evening, a distinct advantage for the legal team under a tight deadline.
- Operating at short notice from the client, Altlaw was able to deploy a team on the ground in Istanbul, Turkey to perform document scanning and [ESI](#) data collection across three separate locations. The data collated was then brought back to the [UK](#) for hosting purposes.
- A simultaneous forensic collection in the [UK](#), [Ireland](#) and [Asia](#), which demonstrated our flexibility and truly global capability.
- Numerous occasions where local document production was performed on behalf of international partners in the US and Europe.

Strategic partnerships developed with other trusted, proven vendors across the US and even into Asia, allowing us to provide a global synchronised, seamless eDiscovery service.

8.1.5 Alvarez & Marsal

Phil Beckett, Managing Director	
pbeckett@alvarezandmarsal.com +44 20 7663 0778	
One Finsbury Circus, London, EC2M 7EB	
www.alvarezandmarsal.co.uk	
<p><u>Company Description</u></p> <p>Alvarez & Marsal (A&M) is a global professional services firm specialising in turnaround and interim management, performance improvement and business advisory services. A&M delivers specialist operational, consulting and industry expertise to management and investors seeking to accelerate performance, overcome challenges and maximise value across the corporate and investment lifecycles. The firm is known for its distinctive heritage, hands-on approach and relentless focus on execution and results.</p> <p>A&M was founded in 1983 when Tony Alvarez II and Bryan Marsal recognised the opportunity to provide radically different advice and hands-on support to organisations facing operational and financial hurdles – situations demanding action, objectivity and real results. Committed to its core values, A&M has since evolved from a boutique player to a leading global professional services firm, setting the standard for working with organisations to solve complex problems, boost operating performance and maximise value for stakeholders. Our more than 3,500 professionals spanning across 55+ offices located in North America, Europe, the Middle East, Asia and Latin America, constitute a diverse group of seasoned experts.</p> <p>Our team of seasoned experts and dispute specialists provide end-to-end advisory services across investigation and litigation lifecycles, in context of anti-bribery and corruption, anti-cartel, regulatory inquiries, complex financial disputes, accounting irregularities, M&A disputes, security breaches, intellectual property theft, employment disputes and other general frauds. A&M’s professionals includes:</p> <ul style="list-style-type: none"> • Forensic technologists; • Digital investigators; • Structured data analysis specialists; • Cyber security specialists; • Forensic accountants; • Former industry executives; • Former regulators; • Former law enforcement officers; • PhD economists; • Banking and securities professionals; • Certified Fraud Examiners; • Chartered Financial Analysts; <i>and</i> • Information governance professionals. 	
<p><u>Vendor Offerings</u></p> <p>A&M’s Forensic Technology professionals are located in major cities around the world and we have datacentres strategically placed in major cities in the U.S., U.K., Germany, Dubai, Hong Kong and mainland China so that we can deploy our expertise at a moment’s notice and accommodate jurisdictional data regulations.</p> <p>Our Forensic Technology Services practice provides repeatable, auditable and proven solutions by combining our operational experience with innovative, legally prudent procedures and the “appropriate” technology.</p>	

This allows A&M to deliver rapid response to requests for electronic information; accurate results with fewer surprises; and reduction in costs by elimination of unnecessary efforts.

Our core competencies within our Forensic Technology Services practice stretch across the information lifecycle, with specialisation in the management, extraction, analysis and presentation of vast volumes and complexities of electronic information.

A&M's collaborative approach to discovery management involves working alongside outside counsel, the clients' internal team and other professionals to deliver a comprehensive solution, combining advanced technology and expert advisory services to deliver strategic value.

A&M is tool-agnostic and continuously assess the leading tools in the industry that will best complement A&M's methodologies. Additionally, we are enthusiastic about customising our workflow according to the requirements from the client and establishing maximum efficiency and high quality. To this affect, we utilise a combination of third-party software and internally developed tools as appropriate. Some of the third-party tools currently utilised within A&M include EnCase, FTK, Blacklight, LAW, Nuix, eDiscovery Platform, and Relativity, in addition to other workflow management, support and reporting platforms.

We regularly support large scale electronic document review exercises across multiple review platforms and regions, but some of our highlight credentials include:

- kCura Premium Hosting Partner with 9+ years Relativity support.
- 15+ dedicated review managers, between 7 and 10 years Relativity experience (including certified RCA's), strategically located throughout the US, Europe and Asia.
- Over 300 individual Relativity workspaces supported with more than 80M documents hosted - largest workspace has over 18M documents.
- Extensive experience in deployment of efficient review work flows incorporating advanced analytics features, including email threading, near-duplicate identification, continuous active learning and Technology-Assisted Review (TAR).
- Multiple self-developed custom platform workflows, applications, objects and advanced field deployments, including participant and domain parsing and categorisation tools, advanced Pivot-based analytics, and redaction propagation.
- Hosted and mobile review platform deployment and support throughout US, Europe, Middle East and Asia.

8.1.6 Anexsys

<p>Matthew Beilin matthew.beilin@anexsys.com 020 3217 0315</p>	
<p>58 Farringdon Road, London, EC1R 3BP</p>	
<p>www.anexsys.com</p>	
<p><u>Company Description</u></p> <p>We solve the toughest data challenges for clients in the private and public sectors. Since 2004, we have provided clients with access to cutting-edge legal technology and a range of litigation support services. We offer the quality and experience you expect from working with a large consultancy, with the price, flexibility and independence of a smaller organisation. We pride ourselves on always providing a first-class experience for our clients from our centres in London, Manchester, Leeds, Birmingham and Bristol.</p> <p>Our differentiators:</p> <ul style="list-style-type: none"> • We custom build innovative software to extend the capabilities of document review platforms such as Relativity. • We are the only provider to hold both the “Best-In-Service Blue” and “Custom Development Partner” Relativity accreditations. • We are headquartered in the UK with ISO27001, ISO9001 and Cyber Essentials certifications. • We are part of the Crown Commercial Service eDisclosure Services framework (RM3717), trusted to handle HM Government data at the highest levels of security. • We provide a 24/5 hard copy service to support our software and electronic document capabilities. • We are ranked by Chambers & Partners for litigation support. 	
<p><u>Vendor Offerings</u></p> <p>We are capable of supporting clients throughout the lifecycle of an eDisclosure project. Our services include: digital forensics, data processing, document hosting, eDisclosure consultancy, managed document review and hard copy services (including trial bundling). Whilst we are experts in Relativity, we also have extensive experience with other eDisclosure software and platforms.</p> <p>Forensic Services</p> <p>Our forensic services include forensic imaging, collection from mobile devices and enterprise content management systems, remote and on-site collections, expert reporting, expert witness services, device interrogation and data recovery. Our forensics practice standards comply with the Association of Chief Police Officers’ guidelines to electronic evidence.</p> <p>eDisclosure Consultancy and Review Support</p> <p>We tailor our consultancy to the experience level of our client. We can provide a comprehensive service, addressing every element of our client’s document review and disclosure requirements. Alternatively, we can restrict our service to back-end application support for highly technical in-house eDisclosure professionals.</p>	

Managed Services

We provide a managed service for clients in the private and public sectors with their own instance of Relativity. Our managed service includes technical support, environment and infrastructure management and the implementation and maintenance of third-party applications and integrations to Relativity. Our managed service clients range from top 15 corporate law firms to public bodies requiring highly secure isolated environments.

Managed Document Review

We have a track record of delivering complex and time sensitive document review projects. We work with clients to create strategic workflows that ensure defensible accuracy and quality control. Our methodology is pragmatic and is aimed at preventing the costs of document review spiralling out of control. We have a dedicated managed review space in Holborn to house large document review projects.

Software development

We have a dedicated Relativity software development team and our innovative products are listed on Relativity's ecosystem. Our Products include:

RTK Excel Redact

Easily redact native versions of Excel documents within Relativity. Applying redactions to an excel spreadsheet which has been converted into an image or pdf can be a problematic. RTK ExcelRedact solves this by allowing users to apply redactions to native excel spreadsheets within Relativity.

RTK Redact

Redact information across document duplicates. Making consistent redactions across duplicate documents is time-consuming and error-prone. RTK Redact saves time and cost when performing redactions by enabling users to automatically apply made to one to document to all of its duplicates.

RTK Message

Import data from social media sites such as Facebook to Relativity and review them in a user-friendly manner. Using RTK Message, reviewers and administrators can quickly filter the message data to remove irrelevant content, and promote only potentially relevant data to the main document review.

RTK Loadfile

Transport data in and out of review platforms and easily check for missing data. RTK Loadfile automates common loadfile tasks. Users can compare a loadfile against a Relativity workspace to ensure no data is missing. It also splits loadfiles for faster ingestion and helps to comply with the requirements of a production or disclosure specification.

With all our Review Tool Kit (RTK) products, we offer interactive software demonstrations, a proof-of-concept period in our clients' environments as well as a proportion of ongoing support for the duration of their licence.

We thrive on being challenged and develop custom solutions for law firms and public sector clients. We work closely with clients to fully understand their complex requirements and custom-build powerful solutions accordingly.

8.1.7 Ankura

Tanya Gross – Senior Managing Director	
+44 (0) 20 7015 8803 +44 (0) 07497 753 354 Tanya.gross@ankura.com	
Woolgate Exchange, 5th Floor, 25 Basinghall Street, London, EC2V 5HA	
https://ankura.com/expertise/ediscovery/	
<p><u>Company Description</u></p> <p>Ankura is a global business advisory and expert services firm with a global footprint across the US, Middle East and Asia. We have 1,400 employees in over 30 offices worldwide.</p> <p>Our Data and Technology team are experts and advisors in complex data risk management, handling critical risk issues across an organisations data enterprise. Providing support and guidance on our client’s most challenging data issues.</p> <p>We tailor our services to support our client’s requirements across a variety of matter sizes and types. Our team of eDiscovery, digital forensic and Cyber & information security advisors provide consulting expertise and end-to-end project management across the full information lifecycle. Our consultants work collaboratively with clients to identify, contain and analyse issues and design efficient workflows to proactively identify and mitigate risk.</p> <p>Our eDiscovery and digital forensics advisory team has significant experience with a broad range of industry-standard technologies and procedures. We apply quality control checkpoints, solve technological challenges, and provide cost-effective solutions. Our professionals have served in some of the largest and most globally recognised eDiscovery investigations. For every unique engagement, we carefully customise our approach to ensure an efficient and well-planned deployment of resources and technology.</p> <p>Our Cyber Information Security and Incident Response team have a proven track record in handling incidents worldwide, with ability to isolate the root cause through remote support or team deployment.</p> <p>Our reactive experience includes, ransomware facilitation, malware and business email compromise analysis and recovery services. Our proactive capabilities include deep offensive security testing, including red teaming, pci assurance, cyber strategy and transformation, privacy/GDPR support, critical national infrastructure and security architecture. We also have the ability help businesses with board level cyber strategy through table top risk assessments.</p> <p>When data incidents give rise to legal claims, our disputes experts guide the parties and their representatives through challenges such as e-disclosure and the analysis of evidence served in the proceedings. Our professionals have served as expert witnesses on technical matters related to liability and questions arising in the assessment of quantum.</p>	
<p><u>Vendor Offerings</u></p> <p>Electronic Disclosure - Ankura delivers unique and powerful capabilities in the most critical phases of e-disclosure. Utilising industry-leading, intuitive, and user-friendly web-based interfaces we equip clients with the best tools so that they are productive immediately with minimal training. Our solutions seamlessly integrate with Ankura’s collection process and allow us to consolidate all processing, analysis, review, and</p>	

production tools into whichever platform is being used. These tools can be hosted in our data centres in the US, EU, or Asia, as well as deployed on-premise behind the firewall.

Processing – Mindseye Discovery Platform, LAW, Nuix, Intelligent Voice®

Early Case Assessment – Brainspace™, Mindseye Discovery Platform

Review – Relativity®, Veritas™ eDiscovery (formerly Clearwell), Reveal™ InControl™, CS DISCO™

Customised Relativity® – Our offering of Relativity includes proprietary review windows supporting audio and chat room formats. These are designed to maximise the efficiency of review teams when compared to many other implementations of Relativity.

Reveal™ InControl™ – Our offering of InControl allows us to instantly and effectively create data centres anywhere in the world via an Amazon Web Service. Minimising hardware and other costs for our clients, ensuring true scalability and reliability.

CS DISCO™ – Our offering of DISCO provides data processing, hosting, ECA and analytics all accessible from a secure Amazon Web Services' platform. This structure allows us to control cost whilst giving access to DISCO's clean and intuitive user interface with fully customisable workflows, views and security.

Advanced Analytics - Ankura's extensive experience with advanced analytical technologies have provided our clients with creative implementation strategies that help establish the facts of the case quickly and enhance the quality of review whilst lowering the cost. Key analytical features include: email thread identification, topic clustering, near-duplicate detection and participant, file, and term analytics. Ankura embeds Early Case Assessment (ECA), predictive analytics and technology assisted review (TAR) functionality directly within our review environments. A predictive coding process that uses statistical validation can help demonstrate to the court and the opposition that the process is thorough and effective.

Brainspace™ - A powerful ECA and analytics tool that allows users to dig deep into their data sets from the time data is loaded throughout the lifetime of the project. Brainspace™ provides visualisation around conceptual clustering, data timelines, communication analysis and other metadata so that users can easily interrogate and quickly understand their large datasets.

Analytics - Our own proprietary predictive coding tool that seamlessly integrates with Relativity, but also acts as a standalone environment. Developed in-house and maintained by machine learning experts, has been used on a large variety of client projects to help prioritise and quickly find the relevant data. The platform uses statistical models for data mining and predictive coding, and is backed by experts who have successfully run defensible projects. The process can be performed iteratively, where results are repeatedly fed back into the system to further refine and enhance the effectiveness of the model. On one client engagement, Predict was able to reduce the number of documents requiring review by over 90%, thereby reducing cost significantly.

Structured Data Discovery - Ankura also deliver strategic business solutions for clients requiring in-depth analysis of large, disparate sets of financial, operational, and transactional data. Ankura uses leading edge technologies and proven methodologies to identify, acquire, and transform massive amounts of complex and diverse information into workable databases. These tools allow for the development of new approaches to assessing and prioritising what is relevant when managing critical cases and issues. Ankura offers the collection, modelling and analysis of the content of databases (e.g. General Ledgers, accounting, HR systems, supply chain / logistics systems, Accounts Payable, CRM systems, customer transactions, etc.).

Ankura has the critical combination of Business, Legal Process and IT expertise to bridge the gap between the key players. Ankura has a team of statisticians, data modellers and visualisation experts to help client get the best insights from the underlying data. For this purpose, Ankura uses visualisation tools such as Tableau and has capabilities to host real-time visualisations that can be accessed from mobiles, tablets, laptop and desktops.

Intelligent Voice® – Using the latest voice recognition software, Intelligent Voice® allows the efficient transcription and analytics of audio data. It allows users to identify themes and concepts in otherwise non-searchable data. Using a continuous active learning algorithm, the software can teach itself different dialects to capture more accurate information. Using Intelligent Voice®, it is also possible to make audio files keyword searchable within a review platform, allowing a more targeted review of audio data files.

Digital Forensics - Ankura's experts are skilled at interrogating a vast range of devices including complex enterprise networks, personal computers and mobile devices to identify relevant intelligence and evidence quickly, accurately and cost effectively. Ankura's professionals possess a unique blend of skills to help clients formulate their strategy, understand their position and deliver answers efficiently. Ankura adopts an agnostic approach to utilising market leading tools to ensure complete success with forensic collections and would analyse which tool is the best and most efficient fit for the client's needs and requirements. Ankura will provide detailed reasons and explanations for tool selection so that the client fully understands the service being provided to them. Ankura is able to intelligently interrogate data to meet specific client requirements which includes recovery of deleted material, analysis of artefacts and identification of malicious applications and/or data. Ankura will create a deliverable that is easy to comprehend and understand, be it witness statements, affidavits or expert reports.

Information and Cyber Security – Ankura's Cyber Security services cover the full spectrum of cyber response, from proactive assessments and hardening of security defences to reactive breach investigations. We are a preferred forensic partner with most leading global cyber insurance companies with clients in banking, utility, retail and legal sectors and investigated over 1000 breaches last year. This gives the team an in-depth perspective on cyber security matters which we leverage in our Cyber Intelligence 360 programme; akin to an MRI scan of an organisation's cyber security health. We can typically be on site in any global location within 24 hours. We also leverage industry technology partnerships to deploy software across the affected network and begin the remote containment and analysis of an incident within hours of being notified.

Data Privacy and Compliance Services (GDPR) - Ankura has expert industry experience in helping clients to operationalise the GDPR utilising a 55-point compliance framework. Ankura's experts help create a variety of procedures to achieve compliance, including incident response plans, subject access requests procedures, and record retention plans. Implementing these policies and practices to address the challenges posed by GDPR provides tangible and long-lasting benefits that extend well beyond regulatory compliance: in creating up-to-date records on privacy policies, data, risks, and IT controls, organizations will likely see improvements in storage management, business continuity planning, and risk mitigation, as well as an overall reduction in their information security threat profile. Clear data classification and typing also enables better disaster recovery and business continuity planning. Such investments toward GDPR compliance can therefore produce multiple benefits and companies that embrace this process may very well find that they have a broader global advantage in the not-too-distant future.

8.1.8 Aon’s Cyber Solutions (formerly Stroz Friedberg)

<p>Mark Brannigan mark.brannigan@aon.co.uk 020 7061 2223</p>	
<p>Capital House, 85 King William Street, London, EC4N 7BL</p>	
<p>www.aon.com/cyber</p>	
<p><u>Company Description</u></p> <p>Aon’s Cyber Solutions offers holistic cyber security, risk and insurance management, investigative skills, and proprietary technologies to help clients uncover and quantify cyber risks, protect critical assets, and recover from cyber incidents. Our multidisciplinary team of 600+ professionals globally are exclusively engaged in delivering a range of cyber assessment, quantification, mitigation, transfer, testing or response solutions for our clients, and uniquely positioned to support the cyber security and risk management objectives of organisations across all industries</p> <p>Our cyber security professionals (formally Stroz Friedberg) have deep experience in the fields of digital forensics, incident response, security science, investigation, eDiscovery, intellectual property, and due diligence. Our key ingredient is the combination of our diverse skill sets and expertise all working together to deliver on your most complex cyber challenges across the entire cyber risk value chain. We are the go-to firm for organisations and their law firms in investigating ninety percent of the highest profile breaches in the last decade, including serving Fortune 100 companies, 80% of the AmLaw 100, and the Top 20 UK law firms.</p> <p>Learn more at www.aon.com/cyber</p>	
<p><u>Vendor Offerings</u></p> <p>How can we help you to reach a successful outcome with Discovery and Disclosure?</p> <p>Core eDiscovery Services: Our eDiscovery service offerings go beyond standard processing, analysis and production services, bringing our ingrained investigative and analytical approach to solving any data interrogation or disclosure requirement. Our problem-solving approach and goal-oriented eDiscovery & Disclosure workflows are designed to meet the needs of any matter, defensibility and proportionately. We show our clients time and time again that scoping and targeting the right data sooner in the process results in huge reductions in effort and review costs later. We provide proactive guidance and leverage the newest technologies and smart approaches to generate meaningful information early on and reduce volumes along every step of the workflow.</p> <p>Consulting & Subject Matter Experts: Providing advice and guidance throughout the process is routine, not the exception. Our experts can help in countless ways - from guidance with negotiating an efficient disclosure plan; building an efficient and defensible cross-border workflow; designing a “proof of concept” exercise for a unique inquiry; advising on internal investigation approaches; document authentication including analysing produced documents to find evidence tampering or defending against claims of tampering; and all the way to helping validate and defend the final results of your review.</p> <p>Technology-Assisted Review & Machine Learning: Our tools and workflows make full use of “TAR 2.0” technologies, such as continuous, active, and multi-modal</p>	

learning, that are language-agnostic. We have the ability to apply powerful machine learning to handle real-world challenges like internal investigations and lines of inquiry; apply early intelligence to subsequent case developments and rolling collections; and effectively reuse existing attorney decisions on relevance, private or privileged information, and cull clearly irrelevant material up front.

Digital Forensics: We are leaders in the field of digital forensics, and help shape best practices on digital investigations and risk management and are recognised industry experts. Our experts have been certified in multiple jurisdictions around the world and have experience of providing expert witness testimony and formal reporting to law enforcement.

Global Locations: We can host data in our highly secure data centres in London, Zurich and New York. Our technology supports foreign languages and our support teams include native speakers in local languages.

Enterprise Advisory: Building on our core eDiscovery, Investigations and Digital Forensics expertise and experience, we regularly advise our law firm and corporate clients through a range of complimentary services designed to reduce their critical information risks including:

- Cyber Security Assessment, Test and Advisory Services
- Incident response – in the event of a Cyber Breach/ GDPR
- Information Governance Consulting – supporting clients to develop and mature corporate information governance programs
- Managed Services Consulting - Our managed services engagements provide consulting services on a broad spectrum of issues covering cyber risk, eDiscovery and beyond.

Available Tools

Processing

Our processing solutions, Nuix and Relativity, handle the most challenging data volumes and types.

Brainspace™ Analytics

Our analytics options help lawyers winnow data and prioritize key documents for litigation and investigation. Brainspace™ Analytics helps you quickly explore and cull large data sets with powerful visual analytics, concept search, query expansion, clustering, and communications network analysis. Brainspace Advanced Document Classification supports continuous multi-model learning (TAR 2.0) as well as traditional Predictive Coding (TAR 1.0) workflows.

Review

Aon's Cyber Solutions supports Relativity to provide native review, enhanced search, near duplicate identification, concept clustering, and multiple reporting options.

Solutions:

Defensible Collection: Whether for litigation or an investigation, whether forensic, targeted, or even covert, we can handle it and make sure it's done right.

Intelligent Data Culling: We apply tested methodologies to help quickly identify and set aside objective irrelevant or low-priority data early in the process, minimising "false positives" and allowing matter teams to focus on the most interesting and important material.

NOMAD Portable Discovery & Disclosure: Our self-contained appliance that is deployable anywhere in the world. No matter the size, location, or complexity of the matter, NOMAD provides clients with a secure, powerful, and flexible system for sensitive investigations and electronic discovery/ disclosure projects.

Multiple Language Support: Includes machine translation, language identification, Multilanguage entity extraction and tokenization, native language search and review, and full support for multi-byte character sets throughout the process.

Cross-Border Workflows, including Privacy Analysis & Redaction: Leverage capabilities in multiple jurisdictions and expert consulting to design workflows that reduce risk and comply with data protection requirements (including analytics and sampling to help identify at-risk data; streamline review; and automate redactions).

8.1.9 ayfie Group AS

<p>Rob Wescott rob.wescott@ayfie.com +1 (917) 930-7600</p>	
<p>ayfie Ltd. c/o Barclays LawTech Lab, 81 Palace Gardens Terrace, Notting Hill, W8 4AT London</p>	
<p>https://www.ayfie.com/</p>	
<p><u>Company Description</u></p> <p>ayfie is a leading software company for information retrieval and big text analytics for the legal industry. It delivers scientifically-advanced linguistic technology that reveals answers to your most difficult questions by extracting valuable insights from massive amounts of “big text”. ayfie’s core products are ayfie Inspector for Relativity® and ayfie Locator for knowledge discovery.</p> <p>Our history</p> <p>ayfie Group’s first entity was founded as VirtualWorks near Fort Lauderdale, Florida, in 2009 and has since then launched an enterprise search platform, a predictive search component, a compliance solution and a powerful adaptable text analytics engine. As of March 2018, ayfie AS, ayfie AB, ayfie Inc. and ayfie GmbH are wholly owned business entities of ayfie Group AS. In 2018, the ayfie London office was opened. Over the past years, the group has grown to become one of the leading big text analytics companies offering intelligent knowledge discovery products and search solutions for 500+ customers in Europe and the United States.</p> <p>ayfie Group is an international company with sales office and development teams in Oslo, Fort Lauderdale, New York, Washington, Munich, London and Stockholm.</p> <p>What makes ayfie stand out?</p> <p>30 years of research and experience in linguistics, computational linguistics and computer science have gone into ayfie’s products. Using this knowledge, ayfie has created a unique platform that combines best-in-class search technology with an innovative text analytics engine to deliver efficiency and better insights from vast amounts of structured and unstructured data. The basis of our products is an advanced language processing technology extended with statistical analysis and machine learning components.</p> <p>ayfie’s proprietary platform has been developed to include innovative technologies from the fields of big data, insight engines, advanced linguistic analysis and text analytics. ayfie’s knowledge, experience and technology lay the solid foundation for digital workplaces in companies in every industry.</p>	
<p><u>Vendor Offerings</u></p> <p>ayfie provides unique solutions for content insights, knowledge discovery and eDiscovery. A powerful predictive search module is integrated in all of ayfie’s solutions. The group’s main products are ayfie Inspector and ayfie Locator. See the software section for more details (8.2.4).</p> <p>ayfie offers a free personalized demo for both products that can be requested on the following site: ayf.ie/demo</p>	

8.1.10 BCL Legal

Matthew Porter, Director: London Private Practice	
matthewporter@bclegal.com +44 (0) 20 3651 5617	
46 New Broad Street, London, EC2M 1JH	
www.bclegal.com	
<p><u>Company Description</u></p> <p>Established in 2003, BCL Legal is the UK’s largest legal recruitment consultancy with over 70 staff, including 45 specialist legal recruitment consultants.</p> <p>People led and tech-driven, BCL understands that effective hiring goes far beyond filling a job role. Successful recruiting puts its emphasis on people, quality and speed. BCL operates with unrivalled insight through discipline and location-specific teams and uses integrated technology to match the right people to business needs.</p> <p>Our Document Review team is based in London and offers a nationwide service, working exclusively with many law firms and companies requiring project-based hires. The team is headed up by Matthew Porter who has successfully managed numerous large scale document review projects for law firms ranging from Magic Circle to West End, LPOs and Big 4 accountancy practices.</p> <p>We work with a pool of 2,500 document review lawyers and paralegals.</p>	
<p><u>Vendor Offerings</u></p> <p>Document Review Recruitment Services demand a high level of experience and expertise, and a sense of urgency to deliver immediate solutions.</p> <p>Whether your project requires a team of three or 30, is short-term or long-term, our widespread pool of high-quality candidates, technology-driven database, BCL tried and tested methods, and the concentrated expertise of our team makes us the most trusted Document Review Recruitment Service in London and the UK.</p> <ul style="list-style-type: none"> • Onsite review • Offsite review • Managed review • Technology assisted review • Compliance management • Linguistic testing • Litigation support 	

8.1.12 BDO LLP

<p>Natalie Butcher (Director, Forensic Technology Services)</p> <p>Cheza Ross, Head of Business Development, Forensic Technology Services</p>									
<p>nat.butcher@bdo.co.uk +44 (0)207 893 3480</p> <p>cheza.ross@bdo.co.uk +44 (0)207 893 3377</p>									
<p>55 Baker St, London, W1U 7EU</p>									
<p>www.bdo.co.uk</p>									
<p><u>Company Description</u></p> <p>BDO, the world's fifth largest professional services network, has more than 1,500 offices in 162 countries. Our UK business is a limited liability partnership operating from 18 offices nationwide.</p> <p>BDO provides a range of professional services, including:</p> <table border="0"> <tr> <td>Audit and Assurance</td> <td>Business Restructuring</td> </tr> <tr> <td>Tax</td> <td>Technology Risk Assurance</td> </tr> <tr> <td>Forensic Accounting</td> <td>Business Valuations</td> </tr> <tr> <td>Forensic Technology</td> <td>Business Services and Outsourcing</td> </tr> </table> <p>BDO is known for its excellence in service across all practice areas and jurisdictions. Our highly resourced teams leverage expertise and best practice solutions from our global network, allowing us to offer our clients state-of-the-art technology in a cost and time effective manner.</p>		Audit and Assurance	Business Restructuring	Tax	Technology Risk Assurance	Forensic Accounting	Business Valuations	Forensic Technology	Business Services and Outsourcing
Audit and Assurance	Business Restructuring								
Tax	Technology Risk Assurance								
Forensic Accounting	Business Valuations								
Forensic Technology	Business Services and Outsourcing								
<p><u>Vendor Offerings</u></p> <p>BDO has dedicated and highly skilled Forensic Technology and Risk Advisory teams, experienced in providing professional advice and handling differing volumes of data from a variety of sources across multiple jurisdictions.</p> <p>Central to our practice is our multidisciplinary team of experienced staff. Our skills and expertise encompass disclosure, computer forensics, data analytics and social media analysis.</p> <p>Our service offering includes:</p> <ul style="list-style-type: none"> • Data profiling and scoping and custodian interviews; • Digital forensics: data collection, file extraction & analysis, investigations and expert witness testimony; • Data processing and early case assessment; • Information governance and regulatory compliance consultancy including GDPR; • Litigation readiness: data profiling and mapping, legal hold program planning and implementation, eDisclosure readiness assessments, corporate eDisclosure program development; 									

- Cyber security: threat and vulnerability intelligence services, security compliance services, information and cyber security strategy services, security improvement planning, security incident response services;
- Social network intelligence analysis;
- Electronic disclosure: strategy and workflow development, data migration oversight, project management, document review management services, search validation, technology assisted review, post review quality assurance, production;
- BDO Leverage; advanced data analysis, pre-collection analytics, pre-review planning, review optimisation;
- Manipulation and analysis of structured data;
- Expert witness services; and
- Managed services.

Our software tools include:

Forensic Collection and Analysis: EnCase and FTK

EnCase and FTK are two of the leading computer forensic suites, regularly used in criminal investigations and both having a track record in court acceptance. These tools are utilised for forensic data collection, processing and analysis. They are used by BDO to recover deleted data, complete comprehensive investigations with disk-level forensic analysis and authenticate metadata, while maintaining the integrity of the evidence. BDO's forensic technology team includes qualified EnCase Certified Examiners with expert witness experience.

Forensic Collection and Analysis of Mobile Devices: UFED

Cellebrite's UFED solution is used for the preservation and investigation of data stored on mobile devices such as mobile phones, portable GPS devices and tablets.

Encryption Handling: Passware and Password Recovery Toolkit

Passware and Password Recovery Toolkit (PRTK) are applications used to recover protected files/devices using various methods including rainbow tables, brute-force and dictionary attacks.

Data Processing: Nuix eDiscovery Workstation

Nuix is the market leading, complete and scalable solution for processing, investigation, analysis, review, and production. Nuix directly indexes virtually all forms of unstructured information, in any language. It can process complex proprietary formats such as Lotus Notes, Microsoft Exchange, Microsoft SharePoint, webmail and forensic images. Nuix technology identifies and makes searchable the information other software routinely skips. Nuix rapidly processes and analyses data in a way that is forensically preserved and defensible, and is used by many of the world's major regulators, including the Financial Conduct Authority and Serious Fraud Office (UK), European Commission (Europe), Securities and Exchange Commission (United States) and Competition Commission (Singapore).

Review Platform: Relativity

BDO is a premium partner with Relativity, offering the Relativity platform hosted in one of our purpose-built data centres, as well as being a RelativityOne Certified Partner. Relativity is a powerful, proven platform which can handle large volumes of data. The flexibility inherent in the tool, and the ability to implement custom workflows, allow BDO's Relativity Certified Masters and Administrators to tailor the

solution to each individual matter and address complex requirements. Relativity also provides analytics functionality which can be used to thread emails so as to cull duplicative content from review, identify textual duplicates/near duplicates, group conceptually similar documents, identify foreign language content and employ technology-assisted review; using your coding decisions to make decisions on remaining documents backed by defensible statistics.

Unstructured Data Analytics: Brainspace

Brainspace is a text analytics tool which is powered by patented machine learning allowing you to interrogate your dataset using visual representations. Brainspace combines powerful concept searching, communications analysis and predictive coding within a single, intuitive interface. Brainspace allows you to find the facts in your data faster, prioritising your review for the most important documents and intelligently culling irrelevant documents.

Structured Data Analytics: MindBridge and BDO Advantage

Through the application of artificial intelligence, the MindBridge engine uncovers material irregularities in data that are caused by human error, or by intent. Using the MindBridge system, organisations across multiple industries can minimise financial loss, reduce corporate liability and enhance their professional judgment.

BDO Advantage is our proprietary tool for analysing structured data. The application incorporates a financial analyser which ingests and analyses general ledger data, as well as supplier and customer analysers. Ingestion has been automated for data sourced from the most common accounting applications including Sage, SAP, Microsoft Dynamics NAV, SunSystems and Oracle. Standard tests can be applied to detect anomalous or high-risk transactions, and a visualised interface allows the user to interact directly with the data to perform their own tests/analyses.

Translation Services: Park IP

Park IP Translations have developed a unique API plug-in technology that enables access to Park IP's machine and human translation resources directly from the Relativity platform. This allows case teams to conduct earlier first pass review of foreign language documents with English-speaking reviewers via your existing eDisclosure process; workflows are virtually uninterrupted.

Depending upon translation requirements, document translations can be produced and delivered immediately. All translated text is automatically delivered back to the Relativity platform and mapped to the source location. From "gist" translation, for relevancy determination, to high quality human translation for critical case documents, the process is simplified and costs are drastically reduced.

Audio Processing: Intelligent Voice

High speed audio and video processing using speech to text and phonetic search, Intelligent Voice allows you to effectively search and cull voice data and add the responsive data directly into your review platform. BDO has successfully employed Intelligent Voice in a foreign language matter involving industry-specific vocabulary using the tool's model building functionality.

8.1.13 blu Eye GmbH (A blu Group company)

<p>Wolf Opitz Governance Risk & Compliance Services</p>	
<p>Keltenring 11 Oberhaching 82041 Germany info@blueye-gmbh.de fon +49 (0) 89 38 888 18 8008 fax +49 (0) 89 38 888 18 888</p>	
<p>www.blueye-gmbh.de</p>	
<p><u>Company Description</u></p> <p>Established in 2012, blu Eye GmbH provides independent INVESTIGATIVE TECHNOLOGY SERVICES & SOLUTIONS.</p> <p>Seasoned management team from the BIG4 audit firms and large technology vendors, with years of experience in multinational projects in Data Analytics (eDiscovery), Information Governance and Security (Data Privacy) and IT Asset Management. The firm offers organizations an impartial perspective on their IT assets, infrastructure and processes, providing clients with unbiased advice in Investigations, Governance, Risk & Compliance.</p> <p>blu Eye provides the best solution tailored to client’s project requirements at flexible pricing models. Its experts are familiar with most eDiscovery software solutions and are certified.</p> <p>An independent services and solution business with deep technical knowledge, blu Eye presents no conflict of interest either as a software catalogue reseller, auditor or law firm.</p> <p>In support of its services, blu Eye employs an extensive network of associated, globally recognized technology partners to enable an efficient, consistent, accurate and expedited review of electronically stored information (ESI).</p> <p>blu Eye applies best practices, industry guidelines and standards in a pragmatic, collaborative and hands-on approach that takes your corporate culture into account. blu Eye’s managed services are designed to support clients proactively to identify and resolve issues before they arise.</p>	
<p><u>Vendor Offerings</u></p> <p>blu Eye Data Analytics (eDiscovery) & Information Governance solutions and practices support the improvement and optimization of workflows, processes- and compliance structures to reduce and prevent risks of fraud and governance violations.</p> <ul style="list-style-type: none"> • Supports corporate compliance and audit teams, legal departments and law firms in accelerated, cost-effective internal and external investigations and reviews. • Helps to ensure that information is fully captured, analyzed, instantly accessible in a defensible manner, ready to take proactive measures in case of audits, disclosures or other legal requirements. 	

- Employs customized eDiscovery tools to enable (near real-time) Early Case Assessments (ECA) to best meet client project requirements.
- Works with best in class eDiscovery software and ancillary product vendors, e.g. AccessData FTK, Elasticsearch, Microsoft Office 365, Nuix*, OpenText (Axcelerate*, EnCase, Decisiv and Perceptiv), kCura Relativity* BlackOut, Systran and X-Ways (*Certified staff members in these applications)
- Offers organizations impartial advice on building a strong holistic Information Governance Policy.
- Planning, setup and execution of parts or the complete Electronic Discovery Reference Model (EDRM).
- Helps to manage Information Governance data remediation processes. That is the overall management of critical Information Governance activities.
- Supports the implementation of the Information Governance Maturity Model.
- Advises on retention of information valuable to meet organizations business, legal and regulatory objectives (i.e. EU GDPR, EU Trade Secret Directive compliance or pre- and post- M&A).

blu Eye Data Analytics (eDiscovery) & Information Governance Services include:

- **Providing Managed services**, advice and guidance on best practices in Data Analytics (eDiscovery)
- **Project- and process management** leveraging client's existing eDiscovery solution whenever it is available
- Support in interviews, culling, document review, coding and tagging, review process, quality-checks, efficiency analysis and reporting
- **Forensic data collection** from various sources to protect potential evidences
- Assessment and capture of electronically and physically stored data and data generating systems throughout the organization
- Server-, Data mapping and identification of applications and data types that are being hosted on respective machines including their location
- **Identification of global custodian data**; the scope, breadth and depth of ESI
- Analysis, categorization and coding of data types (metadata) by i.e. levels of protection, risks and controls, retention period, privileged or privacy status, personally identifiable information (PII), or sensitive personal information (SPI) etc.
- **Legal hold management** and creation of legal / litigation hold questionnaire
- **Market-leading processing and data reduction** of collected ESI – automating De-NIST (analysis of file signatures), Forensic deduplication and search terms
- **Best in class analytics** like Email Threading, Clustering, Concept Search, Technology Assisted Review (TAR) / Predictive Coding
- **Text and Message Mining**, Analysis of Instant Messaging like Bloomberg Chat, Symphony, Slack and Skype. Analysis of message systems like SWIFT and cloud services like Office 365
- Production of documents for courts or opposing counsel
- **Providing data near-line hosting** and assisting in data archiving, deletion and recovery
- **Gap analysis** (As-is versus future state)

Chapter 8 – Supplier & Software Details

- Evaluation of solutions and concepts that align with the client organization's requirements for a comprehensive [data and records management](#) environment
- Supporting development of a centralized data records structure and a directory for core archiving, decommissioning and related processes
- Assistance in the implementation and data remediation of DMS, ERP, ECM and CRM as well as their archives and backups in an integrated approach
- Clean-up, organization and migration of information
- Network of [top-quality multilingual reviewers](#) for first, second level and managed review assignments (German, English and other languages upon request)

8.1.14 Brainspace

<p>Michael Griffin, Director of Marketing</p>	
<p>+1 (202) 436-2196 michael.griffin@cyxtera.com</p>	
<p>15601 Dallas Parkway, 6th Floor, Addison TX 75001</p>	
<p>www.brainspace.com</p>	
<p><u>Company Description</u></p> <p>The company was originally called PureDiscovery when it was formed back in 2007 by Dave Copps and Chris Rhode, both pioneers in the semantic search space. After signing a partnership with Median Capital in 2013 and receiving \$10 Million in growth capital, the company was then rebranded to Brainspace. The Brainspace product is the world’s leading analytics platform for unstructured data. Currently, the product is sold in three major markets which include Litigation Service Providers/Law Firms, Enterprise and Government organizations.</p>	
<p><u>Vendor Offerings</u></p> <p>Brainspace is a data analytics platform that enables its users to make smarter, faster and more informed decisions as it relates to litigation matters, digital investigations, research and intelligence mining. The software is an elegant and powerful machine learning platform designed to accelerate human potential. Brainspace has evolved over many years and continues to lead the industry in unstructured data analytics. We empower people to solve problems at super-human scale.</p>	

8.1.15 Bundledocs (Ireland)

Brian Kenneally	
brian@bundledocs.com +353 21 482 6320	
Westpoint Business Campus, Link Road, Ballincollig, Co. Cork, Ireland	
www.bundledocs.com	
<p><u>Company Description</u></p> <p>Designed for legal professionals, Bundledocs is here to make your life easier. Document preparation and bundling is now simple and effortless. Create document bundles, customise, collaborate, annotate and securely share - any time, any place.</p> <p>Bundledocs evolved from a request from our Chairman and well known Solicitor Frank Lanigan. While working on a particularly large litigation case, he grew frustrated with the process and simply wanted a solution to... <i>“Get a load a paper – a brief, report, deal bible, bundle of document or a pile of stuff from your document management system. Stick them all together. Turn the pile into a neat, numbered, sectioned booklet in minutes, no matter how big or small. Change them in seconds. Share them instantly”.</i></p> <p>And that’s exactly what we did. The power of advanced, secure and powerful cloud technology is testament to the fact that in a short time Bundledocs is now being used in firms across the EMEA, the APAC and Americas.</p>	
<p><u>Vendor Offerings</u></p> <p>We do one job. Help lawyers easily create document bundles, binders and booklets from anywhere.</p> <p>It’s really simple to use. Take documents from anywhere, adjust the order, group them, redact anything you don’t want included and that’s it. Bundles are instantly ready to save, securely share or print – from any device, at any time. We even handle document manipulation, annotations, OCR and online collaboration.</p> <p>At Bundledocs we know it’s imperative that our solution is simple and intuitive to use but also powerful to ensure that every bundle produced is prepared precisely, is of the highest standard and can be provided to any third party in good time. Bundles are now created in minutes – not hours!</p> <p>Our tool eliminates repetitive and laborious tasks to produce binders that enhance the image and reputation of your organization. That’s not all. With Bundledocs you can reduce photocopying, staff costs, and delivery costs, become more environmentally friendly and even move towards a paperless office.</p>	

8.1.16 Casepoint (US)

Amit Dunganani, Director, Corporate Initiatives	
adunganani@casepoint.com +1-703-738-4224	
hello@casepoint.com / sales@casepoint.com +1-844-882-0021	
7900 Tysons One Place, Suite 680, Tysons, Virginia 22102	
www.casepoint.com	
<p><u>Company Description</u></p> <p>Casepoint was founded in 2008 by a small group of legal and technology industry veterans who envisioned creating a cloud-based eDiscovery application that was fast, easy to use, and offered an end-to-end solution in a secure private cloud. Over the past ten years, Casepoint's eDiscovery technology and services has been repeatedly chosen by leading law firms, multinational corporations, and public sector clients for their largest, end-to-end discovery needs. Casepoint has a global footprint with data centers in the U.S. and abroad, and has a team of over 275+ people with a majority of our team focused on technology innovation, design, development, and support. The rest of the Casepoint team is comprised of experienced lawyers, litigation professionals, and technologists who understand the complexities of the litigation cycle and provide truly remarkable project management and technology consulting support to our clients.</p>	
<p><u>Vendor Offerings</u></p> <p>Casepoint empowers legal departments, law firms, and public agencies by providing smarter legal technology combined with award-winning client service. Casepoint eDiscovery is the fast, enterprise class, and next-generation eDiscovery suite from Casepoint, based on more than 10 years of innovation in the industry. It is built upon Casepoint Platform, a highly scalable, secure, and configurable application environment that meets the demands of sophisticated clients within eDiscovery and beyond.</p> <p>Whether SaaS, on prem, or hybrid, Casepoint eDiscovery features cloud collections, data processing, advanced analytics, artificial intelligence, review, and productions – all in an easy-to-use web interface. Casepoint customers benefit from the ability to support sophisticated workflows across millions of documents and hundreds of users, with custom reporting and data management tools built-in. Simple, elegant, and intuitive, Casepoint represents the next generation of litigation technology that will empower your global legal team.</p> <p>Casepoint Offerings:</p> <ul style="list-style-type: none"> • Casepoint eDiscovery • Casepoint Platform • Casepoint Project Management & Technology Consulting Support Services <p>Casepoint eDiscovery is the first, premier application deployed on top of the Casepoint Platform. Based upon the experience of our award-winning eDiscovery system that has been supporting clients for the past 10 years, Casepoint eDiscovery is a full-strength, end-to-end eDiscovery suite. It features accelerated data uploading, culling, analytics, processing, review, TAR, and productions through a powerful and easy-to-use web-based interface. Casepoint eDiscovery supports sophisticated eDiscovery workflows to serve hundreds of simultaneous users per matter, meaningful reviews (including automated QC processes), TAR 2.0, robust</p>	

Chapter 8 – Supplier & Software Details

analytics, and highly customizable productions. The system scales efficiently to tens of millions of records and supports large, multi-terabyte cases.

In addition to our award-winning software, Casepoint has a talented and experienced team of project managers and consultants - comprised of seasoned lawyers, technologists, and litigation support specialists - who are dedicated to providing efficient, cost-effective, and customizable solutions for their client partners throughout the eDiscovery life cycle, 24 hours a day, 7 days a week.

8.1.17 Causasoft LLC (Switzerland)

Dr. Simone Pestalozzi	
info@exhibitmanager.com +41 44 586 40 36	
Im Hoefli 5, 8832 Wollerau, Switzerland	
www.exhibitmanager.com	
<p><u>Company Description</u></p> <p>Causasoft was founded in 2012 by a team of leading international litigation and arbitration lawyers and IT specialists to develop and market ExhibitManager. ExhibitManager has been developed to fulfil the daily needs of litigators and arbitration practitioners when writing legal briefs. ExhibitManager is a user-friendly software that frees you and your team from the distractions associated with handling exhibits in large legal submissions in order to concentrate on your core competence: advocacy.</p>	
<p><u>Vendor Offerings</u></p> <p>ExhibitManager is an intelligent software supporting litigators and arbitration practitioners in legal proceedings, from collecting and reviewing documents, to writing legal briefs as well as creating exhibit bundles with interactive eBriefs. ExhibitManager is the only solution of its kind on the market as it supports all three workstreams: (1) case analysis, (2) inserting exhibits (automatically numbered) into legal submissions with uniform and fully customizable styles, and (3) creating lists of exhibits, bundles and even hyperlinked eBriefs with just a few mouse clicks and without the need for external service providers.</p> <p>Litigators and arbitration practitioners from many jurisdictions are currently using ExhibitManager.</p> <p>Causasoft also offers ExhibitManager training onsite and remote for your team.</p> <p>For more information see the entry for ExhibitManager in the software section, or learn more about ExhibitManager on our web site</p>	

8.1.18 Cellebrite

Jonathan Clayman UK Sales Director EMEA Forensics	
Jonathanc@Cellebrite.com 020 7868 1985 0777 4742805	
68 Lombard Street, London, EC3V 9LJ	
http://www.cellebrite.com/mobile-forensics	
<p><u>Company Description</u></p> <p>Founded in 1999 by a team of highly experienced telecom and mobile telephony professionals, Cellebrite is a global company known for its technological breakthroughs in the cellular industry.</p> <p>Cellebrite was the first company to recognize the outstanding market opportunity in users' mobile content. The company's advanced retail mobile solutions are unique in offering in-store phone-to-phone content transfer, backup and restore, diagnostics, and application and content delivery. In addition, Cellebrite offers retailers monitoring, statistics and analysis of sales activities.</p> <p>In the forensics division, Cellebrite's UFED (Universal Forensic Extraction Device), a high-end mobile forensics solution, extracts, decodes and analyses actionable data from legacy and smartphones, handheld tablets and portable GPS devices for use in law enforcement. Cellebrite also supports the extraction and analysis of Chinese manufactured phones.</p> <p>There are more than 20,000 UFED units deployed to law enforcement, police and security agencies in more than 60 countries.</p> <p>The company employs more than 300 people of whom 170 are engaged in R&D.</p>	
<p><u>Vendor Offerings</u></p> <p>The UFED (Universal Forensic Extraction Device) series is a high-end mobile forensics solution, to extract, decode, and analyse actionable data from legacy and smartphones, handheld tablets and portable GPS devices. See Software sections for more details.</p>	

8.1.19 Cenza Technologies

<p>Andrew Stuart Mills Adi Mirza</p>	
<p>andrew.stuartmills@cenzatech.com +44 7899 000904 adi@cenzatech.com +44 (0) 20 7862 6326</p>	
<p>19-21 Crawford Street, Suite 368, London, W1H 1PJ</p>	
<p>www.cenza.co</p>	
<p><u>Company Description:</u> Cenza delivers scalable, cost-effective and reliable legal outsourcing services built on best-in-class technology, operational expertise, rigorous quality control and unsurpassed client service. We have a consultative approach and provide a range of managed legal services to banks, law firms, consulting firms and document management companies in the U.S., U.K., Canada and Australia. We offer the best of Automation + Human Skill; we automate what we can (including with ML and AI) to accelerate what our skilled resources do. In addition, we are GDPR compliant.</p>	
<p><u>Services:</u></p> <p>Litigation Support</p> <ul style="list-style-type: none"> • Unitising and objective & subjective coding • Customisable coding solution allows data to remain within the U.K. / EU • OCR & clean-up, Excel formatting, Redaction, De-Duplication <p>Document Review</p> <p>Contract Management</p> <ul style="list-style-type: none"> • Clause extraction, audit and abstraction • Negotiation & management support • Monitor obligations and Manage amendments • Legal research and Due diligence review <p>AI & Machine Learning Services</p> <ul style="list-style-type: none"> • Normalizing large data volumes • Training ML systems • Quality control of ML processing <p>Legal Word Processing</p> <p>Real Estate Services</p> <ul style="list-style-type: none"> • Lease review & abstraction • Lease administration • Title review 	

8.1.20 CloudNine (US)

Brad Jenkins	
bjenkins@cloudninediscovery.com +1 714-462-6464,	
14655 Northwest Freeway, Suite 135, Houston, Texas 77040	
www.CloudNineDiscovery.com	
<p><u>Company Description</u></p> <p>Leader in automated discovery, CloudNine empowers legal and business professionals with Discovery automation software to simplify litigation, investigations, and audits for law firms and corporations.</p> <p>Founded in 2002 and based in Houston, Texas, CloudNine is a data and legal discovery technology company with proven expertise in simplifying and automating the discovery of data for audits, investigations, and litigation.</p> <p>CloudNine’s suite of on-premise and cloud-based (SaaS) automation software provides insight and intelligence on electronic data. Adding to its flagship product, CloudNine Review™, the company acquired LAW™, Concordance® and Explore™ (formerly Early Data Analyzer) from Lexis Nexis in March 2018.</p> <p>CloudNine software streamlines the end-to-end, discovery process for attorneys and compliance managers, worldwide and is currently daily by over 1,000 customer organizations to answer their eDiscovery questions and accomplish eDiscovery tasks.</p> <p>Covered in recent reports and surveys by Gartner, 451 Research, Blue Hill Research, Corporate Counsel, and Texas Lawyer, CloudNine is a leader in eDiscovery automation.</p> <p>In addition to its software, CloudNine also provides extensive education to eDiscovery practitioners as highlighted by its publication of the eDiscovery Daily Blog. Authored and edited by industry expert Doug Austin, the eDiscovery Daily is the go-to resource for thousands of eDiscovery and eDisclosure professionals seeking to keep up with the latest news and case law in the world of digital discovery.</p> <p>CloudNine also provides an extensive array of Continuing Legal Education offerings, customized to support client educational requirements.</p>	
<p><u>Vendor Offerings</u></p> <p>CloudNine offerings allow clients to experience the speed and simplicity of secure, self- service eDiscovery automation as well as the power of a full-service eDiscovery provider. These capabilities help attorneys and compliance professionals analyze, process, review, and produce electronically stored information in the conduct of litigation, investigations, and audits.</p> <p>Simplified Discovery Automation Software, powered by CloudNine</p> <p>CloudNine LAW helps legal professionals process discovery data, both electronic and paper, while providing maximum flexibility in production and in export to review. Now enhanced with a new Turbo Import, CloudNine LAW offers a 64-bit, multi-threaded ingestion engine for linear scalability and multi-agent file processing to support the “big data” challenge facing organizations today.</p> <p>Support for over 2,000 file types for importing and exporting:</p>	

- Transfer direct from CloudNine Explore™ and import directly to CloudNine Review and Concordance and other leading document review platforms in a wide range of formats.

Scalable to handle even the largest imaging, endorsing, OCR or print jobs by adding additional agents.

Power production capabilities:

- CloudNine LAW leads the way in document production, including the most flexible imaging and endorsing capabilities.

LAW Core Modules

- Turbo Import: Multi-core, multi-threaded ingestion and processing of data
- Admin: Create cases and exports.
- QC/Edit: Move documents around, add or delete bates numbers.
- Endorse: Brand or burn headers or footers into images.
- OCR: Generate searchable text from image files.
- Print: Print image files out in a batch process with or without slipsheets.

Additional Modules

- Scan or TSI: Scan paper documents into TIFF format.
- TIFF: Create TIFF images from all native documents.
- E-Print: Print native documents to paper.
- Searchable PDF: Create PDF Files that you can easily search.
- Full-Text Indexing: Search all extracted text as well as text resulting from optical character recognition (OCR).
- ABBYY OCR: Create and index readable OCR text for difficult originals and Unicode documents.
- Analytics: Identify near-duplicates and email threads with extracted and OCR text.

CloudNine Concordance enables more than 70,000 litigation professionals to import, review and produce high volumes of eDiscovery documents in-house, with an attractive annual cost and manageable computing footprint.

Robust Searching:

- Search text and metadata to find potentially relevant documents fast.

Review Workflow Management:

- Easily categorize and manage documents with user created tags and tag folders.
- Meet Production Obligations:
- Create image and/or native file productions with corresponding industry-standard load files.

Support Downstream Needs:

- View, annotate and redact images and near-natives for production, or print for depositions and expert witnesses.

Multi-User Support:

- Support multiple reviewers over LAN or WAN and schedule routine jobs using Administration Console.

Maximize Capacity:

- Build databases without predefined limits and work across multiple databases at one time.

Access it Anywhere:

- Use mobile license for case portability.

CloudNine Concordance Streamlined eDiscovery

Import, search and organize email and other electronic documents quickly and accurately:

- Send scanned paper documents and electronically processed files directly from CloudNine LAW™ software to Concordance discovery management software for more detailed review.
- Email and document wizards make it simple to import e-documents—and keep the original formatting, metadata and hyperlinks to native documents, as well as parent-child relationships between email and their attachments.
- Accelerate review speeds using built in features to find or tag related parent and attachment documents.
- Easily change the fields and the order in which they appear in Edit and Table Views for a personalized workspace.

CloudNine Explore provides insight into “big data” quickly and easily to investigate issues, assess risk, confirm compliance and begin early case assessment to complete your project objectives, quickly and efficiently.

- Explore: Navigate through data to identify risk, determine scope and control cost.
- Assess: Inspect and review data using automated and in-person processes.
- Protect: Securely load, ingest and preserve data needed for ongoing investigation or litigation.
- Deliver: Provide information as required for legal production or further investigation.

Core CloudNine Explore Technical Overview

- Core CloudNine Explore Technical Overview
- Step-by-step and advanced user workflows.
- Drag and drop data indexing.
- Date, domain, file type, PII and more filtering.
- Search term testing, reporting.
- First Pass Web UI Review with batching, sampling, tagging.
- Foreign language document identification.
- MS SQL Server, DT Search, open API making CloudNine Explore a tech team friendly solution.

- Deploy anywhere – including laptops – enabling you to take the platform where the data lives.
- Cross machine multi-threaded/core in-place indexing including PSTs.
- One million records indexed/hr and ready to search using one machine.
- No file copies necessary until export.
- Scales out across low cost devices.
- Direct index of forensic images.
- Bulk OCR text generation.
- Fully processed native exports.
- Additional functionality available including scan, searchable PDF creation, TIFF image creation, review, productions.

CloudNine Review streamlines the discovery, investigation, and audit process by allowing you to upload documents quickly and begin reviewing your document collection within minutes. CloudNine Review helps users:

Issue and Track Legal Holds:

- Create a customized hold notice and issue to key custodians to facilitate compliance with your preservation obligation. Send reminders or add additional custodians as needed.

Upload Data:

- Enable do-it-yourself collection and uploading of data to a secure on-line repository, enabling you to get the process started automatically without any human intervention required.

Automate Processing:

- Convert documents to a usable form for review. Exclude duplicative ESI with a click of a button. Easily identify non-responsive categories of documents for exclusion from review.

Search and Review:

- Identify potentially responsive documents quickly with robust search capabilities.
- Create review sets for multiple reviewers.
- Add users and data fields as needed.
- Set user rights to control access to functions, fields, and documents.
- View search hit results on rendered text or even images.

Generate Productions:

- Automate production to create precision productions and privilege logs.
- Track multiple productions for later reference in future matters.

Retain Data:

- Maintain collection in a protected cloud infrastructure until the matter allows for data destruction.

CloudNine Review Certifications

Based on the combination of CloudNine's protected cloud data center infrastructure and dedicated cloud environment, CloudNine complies with important standards, certifications, and attestations including:

- FISMA Compliance
- SSAE 16 Type II Audit (Completed)
- HIPAA Compliance
- ISO 27001 Compliance
- PCI DSS Compliance
- CSA Security, Trust & Assurance Registry
- EU-U.S. Privacy Shield Framework
- Swiss-U.S. Privacy Shield Framework

A complete overview of available services can be found online at [eDiscovery.co](https://www.ediscovery.co).

8.1.21 Codex Global

Christopher Bryden	
christopher.bryden@codexglobal.net +44(0)2076479525	
Codex Global, Atlantic House, 351 Oxford Street, London, W1C 2JF	
www.codexglobal.net	
<p><u>Company Description</u></p> <p>Codex specialises in translation and language services within the legal sector. We are driven by technology and underpinned by secure workflows in order to provide a robust service to our Global client base of leading law firms and in-house legal teams. Our in-house project managers as well as specialist network of linguists have vast knowledge of the legal sector in order to meet expectations at even the tightest of deadlines.</p> <p>Covering over 150 different languages, we are able to provide high quality translations for a number of content types relating to legal, finance, property, manufacturing, pharmaceuticals and automotive amongst other areas.</p>	
<p><u>Translation</u></p> <p>We offer high quality translation & proofreading services, covering all subject matters. and we have the capability to turnaround large volumes of documents within short time periods. Our linguists are subject matter experts and we are able to build teams of linguists who will work simultaneously where necessary to meet tight deadlines. We will be pleased to discuss your requirements to determine the most appropriate workflow, taking into account the type of document, subject matter, timescales and end use of the translation.</p> <p><u>Interpreting</u></p> <p>Codex provides interpreting services for a range of scenarios including client meetings, court rooms, depositions, medical appointments and conferences. We will be pleased to provide you with CVs of linguists in advance of any assignments should you or your clients require this.</p> <p><u>Multilingual Document Review</u></p> <p>We are able to provide expert linguists to review documents in multiple languages at your offices (or preferred location). This can prove an efficient way of determining which documents should then be fully translated for further investigation and which can be excluded from any further research.</p>	

8.1.22 Consilio

James MacGregor (MD)	
james.macgregor@consilio.com +44 (0) 20 3808 9634	
10 Aldersgate Street, London, EC1A 4HJ	
www.consilio.com	
<p><u>Company Description</u></p> <p>Established in 2002, Consilio is a global leader in eDiscovery, risk management and compliance, document review, and legal consulting services.</p> <p>The company assists legal departments of multinational corporations and their outside counsel to respond to legal matters, reduce legal spend, minimise risks, and operate more efficiently using innovative software, cost-effective managed services, and deep legal and regulatory industry expertise across a spectrum of industries.</p> <p>Safe Harbor and ISO 27001 certified, Consilio can deploy its services rapidly and efficiently to clients anywhere in the world from offices and data centres in North America, Europe and Asia. Consilio operates one of the industry’s largest suites of eDisclosure services which includes data collection, complex data processing, document hosting, eDisclosure consulting and technology, digital forensic services, data analytics consulting, document review services and Managed Services.</p> <p>Consilio is one of the largest and most experienced Relativity providers in the world. This includes being an “Orange Best in Service” premium hosting partner, having over 10 Relativity Masters worldwide and hosting over 35 petabytes of data (with one database of over 120 million documents). In London, Consilio has maintained Best in Service™ status every year that the accreditation has been available and longer than any other organisation outside of the United States.</p> <p>Consilio has worked on thousands of global projects, including dozens of landmark cases. In one project, the company hosted more than 80 million records in 34 languages and supported more than 1,000 reviewers around the globe. The company’s project managers have diverse law firm, corporate and consultancy backgrounds, averaging 10 years of industry experience in project management, litigation support, managed document review and forensic consulting.</p> <p>Consilio operates more than 70 offices, review centres and data centres in 11 countries around the world.</p>	
<p><u>Vendor Offerings</u></p> <p>Consilio provides a range of services to assist law firms and corporate clients involved in litigation, arbitration, regulatory investigations, internal investigations and competition matters.</p> <p>eDisclosure Consulting</p> <p>Consilio delivers practical advice on approaches to eDisclosure projects, from initial scoping, ‘data mapping’, Electronic Documents Questionnaire drafting and critiquing, production of eDisclosure budget estimates and Case Management Conference support. The company also provides consultancy on complex matters involving global data collections, multiple languages and less easily accessible information sources such as Bloomberg® chat, bespoke/structured databases, instant messages or recorded telephone conversations.</p>	

eDisclosure Technologies

Consilio offers a range of technology solutions to support different stages of the eDisclosure process, from initial assessment of client data through processing, searching and document review to productions. Consilio's proprietary review platform supports a wide range of information sources, including recorded telephone conversations and Bloomberg® chat. Data is hosted within a global network of data centres, and is accessed by legal teams using highly secure, encrypted connections.

Digital Forensics and Collections Services

Consilio forensic experts engage with corporate IT departments in the early stages of a project to map out potentially relevant data sources before deploying to client premises and data centres to preserve, collect and analyse electronic data. Consilio forensic experts are experienced in extracting data from laptops and workstations, servers, handheld devices, "cloud" storage and backup tapes, and other media. Where data exists in a structured form, Consilio experts will liaise with client legal teams to understand the aims of the review and will query the relevant database(s) to create reviewable and producible reports.

Consilio provides digital, forensic-investigative services for a range of matters including infringement of intellectual property rights, compliance investigations and determining the provenance and authenticity of electronic documents in litigation or arbitration. Consilio forensic staff members are experienced in providing expert witness evidence in written reports or testimony.

Multilingual, Document Review Services

Consilio offers three models of document review services to provide clients with the flexibility needed to achieve consistent, defensible, high-quality results within compressed timetables:

Staffing: Clients are responsible for the strategy and process for review and disclosure, but leave the task of assembling a talented team of reviewers to Consilio.

Coordinated Review: Clients leverage the experience of Consilio's expert recruiters and review coordinators while maintaining control over the review workflow.

Comprehensive Managed Review: Consilio provides an inclusive end-to-end service, leveraging its advanced technologies and best practices.

Whether the project is local or global, each option provides access to Consilio's expert recruiters who can assemble a skilled team in as little as 24 hours, drawing from an established pool of legal professionals with native fluency in more than 30 languages and experience across varied matter types and industries. Review location is flexible as clients can choose from any of Consilio's review centres or utilise their own space. Clients can also determine the amount of review oversight needed for the matter.

Clients can utilise flexible pricing models - such as per-document pricing - that facilitate a cost-effective review.

Consilio also offers specialised document review services for contract review and normalisation to a contract management database, or due diligence review as part of corporate transactions.

8.1.23 Control Risks

Satinder Soni (Director)	
Satinder.Soni@controlrisks.com 020 7970 2287 or 07714 541267	
Cottons Centre, Cottons Lane, London SE1 2QG	
www.controlrisks.com	
<p><u>Company Description</u></p> <p>Control Risks is specialist global risk consultancy that helps organisations succeed in a volatile world. Since its inception in 1975, Control Risks has worked in over 130 countries around the world. Through insight, intelligence and technology we help organisations seize opportunities while remaining secure, compliant and resilient.</p> <p>We support clients by providing strategic consultancy, expert analysis and in-depth investigations through to handling sensitive political issues and providing practical on the ground protection and support. Our unique combination of services, our geographical reach and the trust our clients place in us, when crises and complex issues arise, we help you recover.</p> <p>The headquarters of Control Risks have been located in London since the company’s foundation, but a strong global presence is at the core of the company’s strategy. Working across five continents and with 36 offices worldwide.</p>	
<p><u>Vendor Offerings</u></p> <p>At Control Risks you will find a unique team forged from global accounting, eDiscovery and specialty consulting firms. With unrivalled expertise in large scale, complex and cross-jurisdictional matters, we are adept at helping you establish defensible and repeatable processes to deal with high volumes of electronically-stored information.</p> <p>eDiscovery</p> <p>Control Risks can process and host matter data on Relativity in one of their secure data center locations; Berlin, Hong Kong, London, Los Angeles, São Paulo, Shanghai and South Africa. Matters hosted in London will be hosted in RelativityOne.</p> <p>Nuix is also utilised for early case assessment, forensic analysis and preliminary investigations.</p> <p>Cross-border discovery consulting and assistance</p> <p>We help you with the strategic planning, preparation and execution of cross-border investigations and litigations, whatever the size. Our dedicated and global project management team provides quick and open collaboration.</p> <p>Data processing, hosting and production</p> <p>Control Risks supports companies and their outside counsel with defensible data processing and information reduction techniques. Our data processing capabilities supports thousands of file types stored across local networks or in the cloud.</p> <p>Using file type filtering, search term and date range filtering, predictive coding, email threading and custom solutions, we can reduce terabytes of data</p> <p>Early case assessment</p> <p>Control Risks provides early case assessment (ECA) solutions by working closely with you to understand and manage data at the earliest stages. We leverage high-</p>	

speed indexing and a variety of analytical features and reporting capabilities to provide powerful insights into your data.

Robust analytical tools and ECA capabilities enable you to gain an in-depth understanding of your electronically stored information (ESI) before undertaking full-scale reviews. We provide the option to conduct preliminary analysis with Nuix, which can provide domain lists, file types and timelines of the data collected, as well as the ability to run preliminary search terms and date ranges. By providing an advanced look into case facts, we improve your ability to make strategic decisions early in the review process.

Technology assisted review

We offer Relativity Analytics such as email threading, near-duplicate analysis, concept clustering and searching, as well as predictive coding or Relativity Assisted Review.

Relativity Administrators, Experts and Masters can help design automated workflows for predictive coding that include the appropriate quality assurance steps and detailed reporting.

Our team works with law firms to configure, train, execute and monitor the prioritisation and categorisation of documents, as well as assist with executing stratified and validation sampling on the data.

Digital Forensics

The digital forensic experts at Control Risks have over 75 years' combined experience in the securing, recovery and analysis of digital systems. Whether examining standalone computers or large corporate networks, Control Risks has the experience, technology and expertise required to get the results you need. With trained forensic consultants spread across our office network supported by our worldwide team of investigators, we offer our clients a specialised, unrivalled service. Control Risks has first responder forensic consultants in five continents providing localized expertise.

Our digital forensic services include:

Data mapping

Working seamlessly with our investigations teams in local languages, we map the key custodians of data and ESI sources for preservation and collection through interviews with client IT, custodians and witnesses. Control Risks also consults with corporate and outside counsel to ensure compliance with local data privacy and transfer laws.

Forensic analysis and expert reporting

Data collected by Control Risks' forensic consultants can be indexed using both forensic and eDiscovery tools, which enables high-speed searching and retrieval of information according to specific criteria. Indexed data can be searched and analysed by various methods including keywords, date ranges and communication metadata.

Forensic processing of hard disk images also yields technical artifacts that profile computer use, which may be relevant to the case.

We provide expert reporting to document the entire digital forensics process to produce reports and witness statements for law enforcement, corporate counsel and law firms.

Forensic imaging and data preservation

We work to assure live and ambient data will have its integrity preserved to allow defensible analysis and review. When forensic imaging is not possible, Control Risks will perform defensible secure ESI collections and can also perform targeted collection of data that is digitally fingerprinted with a checksum to ensure its integrity.

Mobile device, cloud and social media collection

We are able to image and extract all types of data from a wide variety of mobile phones, tablets and the cloud.

Cloud source data presents a unique set of challenges in terms of data identification, preservation and acquisition – not to mention data privacy and transfer concerns. In accordance with client requirements and relevant data privacy and transfer laws, Control Risks' forensic consultants can collect data from cloud services including webmail, hosted data repositories and social media websites.

Data Analytics

The data analytics team at Control Risks helps organisations acquire and analyse high volumes of financial, operational and transactional data. This uncovers actionable insights to improve operational margins and mitigate compliance risks.

Business insights, visualisation and dashboarding

Analysing enterprise data to identify unexplored growth areas and operational pain points to enables the C-suite to make business critical decisions. We can enhance and centralise your global reporting through intuitive and interactive visualisation dashboards.

We not only automate existing reports to reduce reliance on IT, but empower executives to explore insights and test hypotheses on their own. We can assign probabilities to scenarios and create risk scores so that business stakeholders and compliance officials can see the potential outcomes of their decisions before taking action.

Compliance monitoring

Control Risks has a team of compliance experts and technologists with experience designing and developing compliance monitoring applications that incorporate risk-based transactional analytics and workflow delegation technology to help you meet your regulatory requirements and internal compliance controls.

Whether it is automating fraud detection as part of a compliance assurance programme related to the Foreign Corrupt Practices Act (FCPA), or implementing decision-based workflows to meet the unique business rules of a regulated industry, our development team collaborates with you to create ideas and solutions to satisfy your compliance monitoring needs.

Commercial data reporting

Our data analytics team has extensive experience in analysing financial and accounting data to help companies prepare for business critical events such as mergers and acquisitions, IPOs and other market changing actions.

We work with multinational corporations to solve specific management reporting issues, particularly when timescales are urgent. Our accounting expertise and familiarity with financial systems helps us act as an interim reporting solution to address any shortcomings in existing reporting capabilities. Our team can quickly create ad hoc reporting, ensure accuracy in reported figures and reconcile existing variances.

8.1.24 Critical Data Services

Ciaran Kennedy – Technical Director	 <p>Critical Data Services</p>
ciaran@criticaldata.ie 01438 893715 +353 18612280	
719 Northwest Business Park, Dublin 15, Ireland	
www.criticaldataservices.co.uk	
<p><u>Company Description</u></p> <p>Critical Data Services (CDS) was established in Dublin in 2004 to serve the hard disk recovery needs of clients based in Ireland and further afield. Since formation, additional data retrieval services have been developed, most notably in the area of eDiscovery support in respect of extraction of legacy data stored on tape.</p> <p>Unlike many competitive businesses that provide tape extraction services as part of a wider eDiscovery offering, Critical Data Services has purposely adopted a position as an independent data extraction service, without data review offerings, thus avoiding potential internal or external conflicts of interest.</p> <p>In 2013, Critical Data Services became an accredited service partner of Index Engines, and through continued successes with global eDiscovery and consulting clients has become the Index Engines’ technically accredited tape service provider in Europe.</p> <p>Whereas hard disk data recovery work is usually carried out only at our Dublin Recovery Lab (Full Class-100 Cleanroom Facility), Critical Data Services can offer a mobile short-term or fixed long-term solution deployment anywhere in Europe as dictated by project scale, taking into account data security, data protection, legal and jurisdictional considerations.</p> <p>From an eDiscovery perspective, our focus is the minimisation of time to de-duplicated data from tape, and also on the resultant cost savings that are delivered by tape indexing over the traditional tape restoration which involves full (and duplicitous) restoration of tape content. Our proprietary process wrapped around our Index Engines core technology means that no third-party service will restore selective responsive data from tape quicker than Critical Data Services. Whether you have 1 tape or 1 million tapes, we can help!</p>	
<p><u>Vendor Offerings</u></p> <ul style="list-style-type: none"> • Advanced Data Recovery services from all media types • Law Enforcement data recovery specialists including CCTV Recovery • Backup Tape processing for eDiscovery and backup-platform migration • Voice data extraction and transcription from legacy call-recording systems • Litigation Support – CDS can rapidly extract selective responsive data from almost all tape formats based on content and/or metadata queries. Other service providers usually need to restore the full tape content to get to the data you need. The more tapes in question, the greater the performance benefits of our service compared to our competitors. • Backup Migration – in the case of migration to new backup software or new physical tape, we can cost-effectively migrate de-duplicated legacy data to the new tape format. • Digital Vaulting of Legacy Data - Our Index Engines-based offering is the best solution on the market for projects involving remediation of legacy mail from tape into a live digital enterprise vault. 	

8.1.25 CYFOR

Lawrie Hall, Director.	
lawrie.hall@cyfor.co.uk +44 (0) 207 438 2045	
Becket House, Old Jewry, London, EC2R 8DD	
www.cyfor.co.uk	
<p><u>Company Description</u></p> <p>Since being founded in 2002, CYFOR has been supporting law firms and corporate clients with cost-effective, end to end eDiscovery and advanced Digital Forensic services. These specialisms extensively cover litigation and dispute resolution, as well as commercial, criminal and internal investigations.</p> <p>Our ability to combine specialist forensic data collection techniques with a full suite of advanced eDiscovery workflows provides a leading edge. By harnessing the latest technology, including complex data analytics and processing, we have a proven capability from extraction through to production at every stage of the eDiscovery life cycle. We offer bespoke solutions on highly contentious, multi-lingual and multi-jurisdictional matters, with time critical deadlines.</p> <p>A dedication to the highest level of quality and data security ensures CYFOR is both ISO9001 and ISO27001 accredited.</p>	
<p><u>Vendor Offerings</u></p> <p>eDiscovery: Complete Electronic Discovery Services</p> <p>CYFOR offers complete end-to-end eDiscovery services, incorporating all phases of the Electronic Discovery Reference Model (EDRM), with a proven capability from forensic extraction through to production. Operating internationally, CYFOR supports law firms, corporate clients, regulatory bodies and government agencies involved in litigation, dispute resolution and regulatory investigations.</p> <p><i>Our portfolio of electronic discovery solutions includes;</i></p> <ul style="list-style-type: none"> ▪ Early Case Assessment ▪ Forensic data collection ▪ Document review ▪ Technology Assisted Review (TAR) ▪ Data Analytics & processing ▪ Secure data hosting <p>All services are underlined by dedicated project management, which is fully customised to each project developing the right strategy, addressing data review efficiency and ensuring the analytics tools are maximised. Our eDiscovery specialists are all Relativity certified and have the technical intelligence, consultancy skills and experience to operate as a natural extension to your team.</p> <p>Our secure ISO27001 certified infrastructure, combined with industry leading technology, provides clients with a scalable solution and a single point of accountability to ensure all eDiscovery requirements are met.</p> <p>Fixed Quoting</p> <p>Producing information for review and analysis in response to disclosure requirements can be time consuming and expensive. With over a decade of</p>	

experience in electronic disclosure, we know it's essential to have a handle on costs and have adapted to the Jackson Reforms to offer fixed price quotations.

We provide a highly focussed and transparent pricing methodology to give visibility of costs at the start of any project, ensuring that budgets are accurately controlled and maintained. Also enabling the eDisclosure process to be applied to smaller cases on an investigatory basis. Our client focused, consultative approach has enabled us to deliver exceptional and cost-effective results, time and time again.

Forensic Data Collection

With international experience and remote download capabilities, CYFOR are specialists in forensic data collection. Our fully qualified digital forensic experts are no strangers to complex global data extractions, across the full spectrum of digital devices, under time restrictive deadlines.

CYFOR's digital forensic investigative service covers a range of matters, including;

- Regulatory disclosure
- Data preservation during litigation
- Electronic disclosure
- Compliance investigations

From the first point of instruction, CYFOR provide a bespoke workflow to collate all the data in a forensically sound manner, while advising on the best technical strategies, using the latest software. We ensure all relevant data sources have been identified and mapped out prior to forensically acquiring, analysing and reporting digital evidence.

From extraction through to presentation in court, CYFOR maintains secure evidence continuity, throughout the entire life-cycle of your data.

Document Review

Online document review platforms are powerful and indispensable tools in the eDiscovery process. CYFOR has comprehensive document review services, utilising the latest technology to effectively manage vast amounts of electronically stored information (ESI) on a wide range of complex matters, which can be scaled to meet clients' requirements.

Processing

Through the application of advanced techniques, our eDiscovery Specialists can rapidly process and considerably reduce clients' data volumes within litigation or dispute resolution. CYFOR's processing capabilities have the ability to burst in order to handle large data volumes in short time frames.

Secure Data Hosting

We protect our clients' data by preserving it in our own data hosting environment, which operates on its own independent forensic server. Our high-performance infrastructure is powered by an intelligent security model, allowing 24/7 access and maintenance by a handful of NPPV security cleared senior forensic specialists.

Technology

CYFOR invest heavily in sophisticated technologies, allowing us to provide the best solution for our clients and their budgets across the entire eDiscovery life-cycle. Our end-to-end review platforms include;

Relativity: An industry leading online review platform servicing every part of the eDisclosure process, from legal hold through to production, including Early Case Assessment (ECA) and analytics. It enables case teams to handle the largest, most

complex projects using flexible, customisable workflows and powerful searching and visualisations capabilities—all in a highly scalable environment.

Core features;

- Visual analytics
- Predictive coding
- Email threading
- Data clustering

Nuix: As an eDiscovery solution, Nuix's exceptional power enables CYFOR to process and search vast quantities of data, from collection through to production within the most complex investigations.

Core features;

- Processing power
- Remote email downloads
- Data management & export
- Data exporting
- Web Review & Analytics

Digital Forensics – Forensically acquiring, analysing and reporting digital evidence

Recognised as industry experts, Digital Forensics has been at the core of CYFOR's service offering since inception. With a comprehensive range of forensic services and a proven capability, we have conducted numerous high profile civil and criminal investigations.

Summary of services

- Data recovery
- Forensic data collection
- Mobile phone forensics
- Computer forensics
- Cell site analysis
- Audio visual forensics

We have the expertise to forensically recover, analyse and present digital evidence across a full range of digital devices including, computers, mobile phones, external hard drives and servers.

Forensic Specialists

Individually, CYFOR's highly qualified digital forensic specialists are recognised as some of the industry's leading specialists. As a collective, their combined expertise becomes even more powerful for the most complex of cases, while going above and beyond to exceed client expectations. They utilise the latest technology and digital forensic techniques to discover all potential evidence within a wide range of investigations. Our forensic investigators are all approved Expert Witnesses and courtroom trained. Strict adherence to the ACPO Guidelines and thorough forensic protocols, ensures comprehensive reporting, often concluding with expert evidence presented in court.

Digital Forensics Technology

Digital forensics platforms are powerful and indispensable tools within any investigation and we continually invest in our technical infrastructure and forensic software to enhance our service offering. To enable forensic imaging, data

extraction, analysis and reporting of digital devices we have strong partnerships and full certification with the following leading technology providers;

- EnCase
- FTK
- Cellebrite
- XRY

8.1.26 Data Analysis Services (DAS)

Juan Di Luca / Andrea Valencia	
admin@dasinfo.org +44 (0) 20 8014 5170	
23 Park Road, Sutton, SM3 8PY, UK.	
www.dasinfo.org	
<p><u>Company Description</u></p> <p>Juan Di Luca and Andrea Valencia established DAS in 2012. They have 17 years' of combined experience working for some of the most prestigious law firms and evidence management companies in Europe and the Americas.</p> <p>Their experience at DAS includes cross-border and multinational investigations, as well as routine litigation. Their multilingual team delivers bespoke services and excel at helping law firms, corporate clients and service providers meet their legal investigation challenges by providing professionals of the highest quality on a temporary and permanent basis at a third of the cost of competitors.</p> <p>DAS has managed projects across Europe, America, the Middle East and South America. Our specialised units include, but are not limited to: antitrust and competition investigations; legal forensics; bankruptcy litigation; corporate restructuring; complex financial litigation; WTO disputes; EU data protection; KYC/AML/TF, government administrative and regulatory reviews; Anti-Corruption & Foreign Corrupt Practices Act (FCPA) and LIBOR. Their sector-specific experience includes but is not limited to: pharmaceuticals, telecommunications, transportation, banking & finance, media & communications and the oil industry.</p>	
<p><u>Vendor Offerings</u></p> <p>DAS is experienced with a wide range of document review and information management software, such as but not limited to: Relativity, Brainspace, Concordance, Ontrack, iCONNECT, Ringtail, Summation, iView, Stratify, Attenex, Lexis-Nexis, CaseLogistix, Nuix, Clearwell and Documatrix. We have the ability to scale rapidly in order to handle any project in a timely, cost-effective manner.</p>	

8.1.27 Deloitte LLP

<p>Simon Placks Peter Robinson</p>	
<p>splacks@deloitte.co.uk +44 20 7303 2451 petrobinson@deloitte.co.uk +44 (0) 207 303 2148</p>	
<p>1 New Street Square, London EC4A 3HQ</p>	
<p>https://www2.deloitte.com/uk/en.html</p>	
<p><u>Company Description</u></p> <p>Deloitte LLP operates in 170 countries and has an annual turnover of \$43 billion.</p> <p>Over 1000 professionals across the globe are entirely focused on the provision of Deloitte’s Discovery Consultancy, fully integrated e-Discovery services and technologies.</p> <p>In the UK we have 200 professionals in the Forensic Technology team, and have significant presence ‘in Country’ across Europe. Our management team has over 200 years of Discovery experience.</p> <p>Our approach is to fully understand our client’s requirements and help define the most effective workflows to meet them. We advise and provide services across the whole EDRM spectrum – these are detailed below.</p> <p>Deloitte is software agnostic, and constantly reviews and selects best products to add to the portfolio of our ‘primary products’. These products meet country requirements such as language and product support as well as offering global integration. Our practical and operational knowledge of the variety of e-Discovery software provides the insight to develop bespoke applications to further enhance product functionality.</p> <p>Deloitte’s Project Management principles (such as accredited Prince2 practitioners) ensure that wherever e-Discovery technology and services are required, all procedures, processes and extensive quality controls conform to the high quality standards demanded of a global professional services firm.</p> <p>Deloitte provides e-Discovery services on cases of all sizes – from tens of Gigabytes through to Petabytes.</p> <p>We specialise in cross border e-Discovery where data cannot leave the premises or Country. Our global presence, strategically positioned highly secure data centres and portable technologies, allow us to effectively manage cases where greater consideration may be given to data privacy issues and cultural attitudes.</p> <p>Our services extend beyond traditional eDiscovery and allow clients to address the issues arising from a variety of electronic evidence sources including structured data (databases), Smartphones Instant Messaging, Audio etc. We also provide a full range of Digital Forensic and Cyber investigation service.</p> <p>Deloitte also specialises in assisting clients in the definition of their e-Discovery requirements; producing Tenders to software and services vendors; and helping in any required implementation.</p>	
<p><u>Vendor Offerings</u></p> <p>Deloitte’s Forensic Technology teams provides services across in the following areas:</p> <ul style="list-style-type: none"> • Discovery Consulting 	

- Data Collection
- Data Processing
- Data Hosting
- Review Management and Case Support
- Managed Services
- Structured Data Discovery and services (Data Analytics)
- Audio Recovery and Discovery
- Cyber Crime
- Digital Forensics
- Forensic Expert Services
- Document Review Services
- Contract Lifecycle Management
- Data Rooms
- Data Separation

8.1.28 DISCO (CS Disco, Inc)

Philip Demetriou Rich Bowes	
demetriou@cdisco.eu +44 (0) 7971 087851 bowes@cdisco.eu +44 (0) 7850 218027	
Birchin Court, 20 Birchin Lane, London, EC3V 9DU	
https://www.cdisco.eu/	
<p><u>Company Description</u></p> <p>CS Disco Inc. was founded in Houston, Texas in 2012. DISCO, the edisclosure platform, was initially developed at a litigation boutique law firm in Houston. It was born out of the firm’s frustration with conventional edisclosure tools that were slow and difficult for lawyers to use. Instead of being forced to adapt our work methods to technology, we wanted to invent technology that works the way lawyers work. DISCO was the result, and today we are the fastest-growing edisclosure solution.</p> <p>As the leading provider of software-as-a-service (SAAS) solutions developed by lawyers for lawyers, DISCO is reinventing legal technology to automate and simplify complex and error-prone tasks that distract from practicing law. DISCO has been embraced by more than 400 law firms, including 75 of the top AmLaw 200, as their first choice for innovative technologies that enhance the practice of law to help secure justice and win cases. We have more than 2,800 active matters of all sizes. The largest case hosted in DISCO was 24 TB with more than 150 concurrent active reviewers and no degradation in performance.</p>	
<p><u>Vendor Offerings</u></p> <p><u>DISCO edisclosure platform:</u> An all-in-one cloud-native solution, DISCO edisclosure review software as a service delivers anytime, anywhere cloud collection, transfer, processing, review, search, and production capabilities with a managed turnkey infrastructure delivery model that requires no upfront investment in software or services. DISCO is available for clients in the EU and UK and complies with requirements of the GDPR, with all data being hosted in the EU. DISCO provides transparent and predictable pricing with an all-inclusive per-matter transactional price. Based on pre-expanded data size, it includes all the processing, unlimited users, productions, AI, analytics, and more with no one-off or line-item costs. DISCO also offers subscription pricing options.</p> <p><u>DISCO Managed Review Services:</u> For law firms and corporations that need to review documents in a fast and accurate manner, in addition to DISCO edisclosure review software, DISCO offers an experienced team of project managers and review attorneys to perform small and large managed reviews.</p> <p><u>DISCO Professional Services:</u> While DISCO is designed to be empower our clients to manage their matter end-to-end themselves, if and when clients would like assistance, DISCO’s Professional Services team is available. From project management to data services, our dedicated staff of legal and edisclosure professionals are at the ready to help consult with clients in regards to search, investigative needs, and utilizing AI to deliver value and extraordinary outcomes.</p> <p><u>DISCO Forensic Services:</u> To help legal departments easily perform a comprehensive collection, DISCO provides a full suite of end-to-end forensic services, which include forensic preservation, collection, analysis, and consultation, performed by experienced Certified Forensic Examiners using defensible processes and methods.</p>	

8.1.29 EDRM

James Waldron, Director	
James.waldron@law.duke.edu	
EDRM Duke Law School, 210 Science Drive, Durham NC 27708, USA	
www.EDRM.net	

EDRM at Duke Law School creates practical resources to improve e-discovery and information governance. Since 2005 EDRM has delivered leadership, standards, best practices, tools, guides, and test data sets to improve electronic discovery and information governance. Member individuals, law firms, corporations, and government organizations actively contribute to the direction of EDRM.

Founded in 2005 by attorney George Socha and technologist Tom Gelbmann, EDRM was created to address the lack of standards and guidelines in the e-Discovery/eDisclosure industry. Since its inception, the EDRM community has steadily grown with participation from hundreds of domestic and international organizations, including representatives from service and software providers, law firms, industry groups, law schools, city governments, state attorneys general, state and federal agencies, and corporations involved with eDisclosure.

In 2016, EDRM became part of the Duke Law School. The augmented resources of the Duke community and the Center for Judicial studies have expanded EDRM in its efforts to provide educational and professional resources in eDisclosure and information governance, supporting its mission to promote understanding of the judicial process and improving the administration of justice. In 2017 EDRM embarked on an ambitious journey to expand its number of projects. A comprehensive list with descriptions is included below

EDRM is a global, member-driven organization. EDRM members help shape the legal profession’s technological evolution and are widely recognized as leaders and experts in eDisclosure.

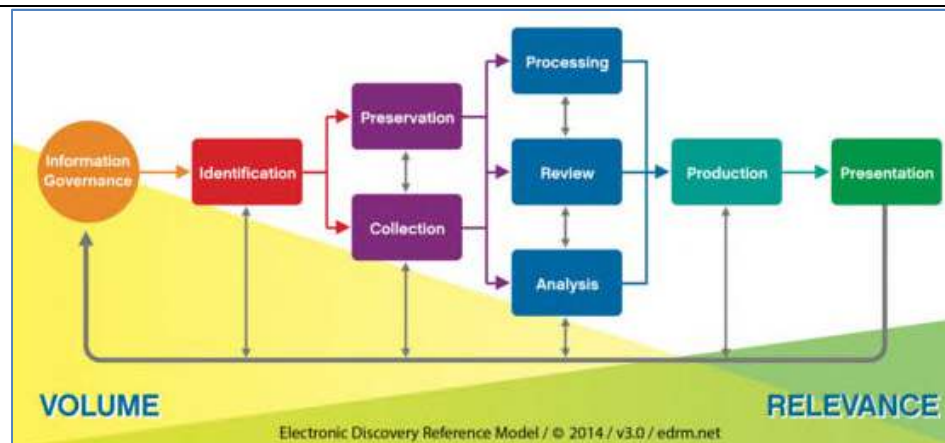

EDRM develops and publishes e-discovery and information governance frameworks. Each framework is designed with two fundamental goals in mind. First, the framework should help people and organizations better understand the framework’s topic – what are the typical major steps in e-discovery, for example. Second, the framework should help them better understand what to do, at a practical level, with respect to that topic. The six EDRM frameworks are:

- [Electronic Discovery Reference Model](#)
- [Technology-Assisted Review Reference Model](#)
- [Information Governance Reference Model \(IGRM\)](#)
- [Metrics Model](#)
- [Privacy & Security Risk Reduction Model](#)
- [Talent Task Matrix](#)

EDRM Active and New Projects for 2019

EDRM REVISION – Recognizing that the EDRM model has not had a refresh in some time, the project focuses on updating the underlying documentation of the EDRM model to reflect changes in technology, process, and the law.

GDPR PROJECT – The project team is working toward developing a code of conduct for cross-border discovery under the EU General Data Protection Regulation. EDRM formed the team in August 2017 to examine GDPR and develop guidance for becoming GDPR compliant, particularly with an eye toward the regulation’s impact on cross-border discovery. Initially focused on data transfers from Ireland to the U.S., the guidance is aimed at mitigating some of the risk that international litigation teams and e-discovery practitioners face when balancing U.S. discovery obligations against European data privacy laws.

IGRM – The Information Governance Reference Model was initially created to frame the discussion of information management, in the same way the Electronic Discovery Reference Model functions for e-discovery. The project focuses on updating the IGRM model as well as recognizing the interconnection between this project and the Maturity Assessment project. Maturity is measured in part by reviewing the level of collaboration among key stakeholders which is at the very core of excellent information management.

PROPORTIONALITY – The project’s goal is developing a template, which provides a common analytical framework for lawyers and the court to use when presenting and considering a proportionality assessment in litigation. This tool will focus on the six proportionality factors, especially factor six, which weighs burden and expense against benefits. The factors are laid out in Fed.R.Civ.P. 26.

COMP SCI/STOP WORDS – The project’s goal is developing glossaries and resources to explain basic computer science terms and principles and to compile a list of common “stop words” used in e-discovery and the complications that may arise from using them.

PRIVILEGE LOGS – A privilege log is a record of the responsive or relevant documents that are being withheld from production on a claim that they contain attorney-client communication, attorney work-product, or trade secrets. The purpose of the project is developing best practices that most efficiently accomplish the task, including consideration of possible rule amendments.

ARTIFICIAL INTELLIGENCE – Artificial Intelligence is a wide ranging and pervasive methodology reaching all areas of life. The project explores its use in litigation and how it will continue to develop. The project explores and develops opportunities to educate lawyers and judges on the role of AI in litigation.

EDISCOVERY MATURITY ASSESSMENT – The project’s has developed an interactive tool to measure a company’s e-discovery management based on the EDRM maturity model, which was developed several years ago. It fosters a simpler first analysis of an organization’s eDiscovery maturity and hopefully leads them into a deeper analysis, which is provided by the more detailed EDRM maturity model. It is under ongoing analysis and can be found [here](#).

TAR PROJECT – The project seeks to improve the administration of justice by establishing authoritative guidance that the bench and bar can rely on with confidence and by providing guidance on how best to use TAR and under what circumstances. This document has been completed and can be found [here](#).

Opportunities for participation:

Become a member, join a project team, become a sponsor, participate in workshops and Duke Conferences.

Visit www.EDRM.net, or send us email at EDRM@law.duke.edu

8.1.30 edt

Gayle O'Connor	
gayle@discoveredt.com +1 206-356-7688	
www.discoveredt.com	
<p><u>Company Description</u></p> <p>Since 2002 EDT has established an international reputation as the first provider of end-to-end software to manage disputes, investigations, and litigation. EDT is trusted by an international blue chip client base including GLOBAL 100 law firms, top tier accounting firms, corporations, government agencies, forensic experts and consulting service providers. With offices and clients throughout South East Asia, the United Kingdom, the United States and Canada, EDT is well positioned to address emerging challenges in this exciting, expanding legal technology industry.</p>	
<p><u>Vendor Offerings</u></p> <p>Software provided – EDT. Covers case lifecycle from processing to production in one tool.</p> <p>Training and certification programs available.</p> <p>Hosting of EDT as Platform as a Service in the Cloud with EDT.Blue</p>	

8.1.31 eMag Solutions

Ian Bartlett (Director)	
ibartlett@emagsolutions.co.uk , 07956 024700	
2A Oaktree Court, Cardiff Gate Business Park, Cardiff, CF23 8RS	
www.emagsolutions.com	
<p><u>Company Description</u></p> <p>With over 55 successful years delivering service, eMag Solutions is a specialist tape restoration and data services company providing data, email, voice and Instant Messaging solutions. Uniquely, eMag has a heritage in the design, manufacture and processing of tape and have an in depth understanding of the media and corporate information storage methods. Much of the media that is today being restored in the course of litigation and regulatory inquiries was manufactured by eMag. Operating from secure centres in the UK and US and also on-site anywhere in the world, eMag are able to provide full support for any tape created using any backup format. Processing for all email and document types as well as voice recordings and IM systems completes the tape and data services portfolio.</p>	
<p><u>Vendor Offerings</u></p> <p>eMag solutions is a specialist tape and data services provider with unrivalled experience in the handling and restoration of back-up tape and the information stored upon it. Operating from secure UK and US premises (ISO 27001 certified) eMag can catalogue, index and restore data from any tape type, created using any backup software. Voice tapes are also fully supported with indexing, selection and review of calls from a range of logger systems. The production centres in the UK and US are purpose designed and can quickly scale to handle jobs involving 1 tape or several thousand. Using automation and with a stock of hundreds of drives of all types eMag is able to process more tapes, of more types and formats more quickly, securely and effectively than any other provider. Utilising MM/PC - the robust and proven specialist tape restoration software - the original backup software and a range of specialist utilities, eMag ensures a level of accuracy of result that is not possible using alternative, single appliance type, solutions. With full email, voice and document processing capabilities – covering all systems – eMag can process data to the point of upload to your choice of review system.</p> <ul style="list-style-type: none"> • Full range of delivery options: On & Off-site, MM/PC Appliance, Software Only • Secure, purpose designed UK facilities • Solution for all tape types and formats • ISO 27001 • Full service available on-site anywhere in the world • eMail, Voice, Data & Instant Messaging solutions • Highly scalable solutions to cater for any volume of tapes 	

8.1.32 Epiq Systems

Justin Collins	
JjCollins@epiqglobal.co.uk +44 (0) 20 7367 9140	
11 Old Jewry, London EC2R 8DU	
http://www.epiqglobal.com	
<p><u>Company Description</u></p> <p>Epiq, a global leader in the legal services industry, takes on large-scale, increasingly complex tasks for corporate counsel, law firms, and business professionals with efficiency, clarity, and confidence. Clients rely on Epiq to streamline the administration of business operations, class action and data breach services, court reporting, eDiscovery, regulatory, and compliance matters. Epiq subject-matter experts and technologies create efficiency through expertise and deliver confidence to high-performing clients around the world.</p> <p>Epiq provides global support to corporate and legal entities with a wide range of legal support services, partnering with clients to manage collection, processing, hosting, review and analysis of material for large and complex matters.</p> <p>The size and scope of our operations, alongside our industry expertise allows Epiq to provide an end-to-end service, with solutions across all stages of the eDiscovery process.</p> <p>The Epiq platform extends to 14 countries, including more than 80 office locations, more than 5,000 employees and a dozen data centres across the globe serving our clients. Epiq helps law firms, corporations, financial institutions, and government agencies manage complex, large-scale data sets and requirements of eDiscovery, bankruptcy, class actions, court reporting, regulatory, compliance and other critical legal tasks. In the U.K., Epiq works with 5 of 5 Magic Circle firms, and 17 of the 20 largest law firms. In the U.S., Epiq works with 48 of the 50 Am Law firms.</p> <p>Epiq co-located data centers are SSAE 16 and ISO 27001 certified, all with hardened exteriors sitting on dual power grids, employing generator backup and 24/7/365 closed circuit and manned monitoring. Project managers coordinate with global teams to provide seamless, reliable, around-the-clock client support.</p>	
<p><u>Vendor Offerings</u></p> <p><u>eDiscovery Services</u></p> <p>Epiq offers a breadth of eDiscovery solutions, including data collection, forensic analysis, processing, hosting, document prioritisation and production. We offer clients a single point of accountability for all eDiscovery needs.</p> <ul style="list-style-type: none"> • Data Collection: Epiq is uniquely equipped to handle worldwide projects—we have experts around the world, the ability to deploy teams on-site globally, and the experience to navigate through country-specific data protection laws. Epiq provides onsite or remote collection services to law firms, corporate and government clients and our certified forensic examiners are highly skilled investigators trained to execute defensible evidence handling procedures. Epiq’s Forensics and Information Governance teams work with clients to set up repeatable, defensible, and efficient preservation processes. Preservation processes incorporate both third party and native tools, depending on the target data source, and we are able to collect data from disparate sources including mobile devices. • Processing: We process more data globally than any other eDiscovery provider. This experience and scale allows us to solve the industry’s most challenging data problems on behalf of our clients. 	

- Hosting: Epiq currently has 12 data centres worldwide in which it can host client data. Client data will be maintained in locations as determined during project planning, and in accordance with regulatory requirements. Epiq offers both DMX and Relativity, two of the leading document review platforms on the market.
- Document Prioritisation: Epiq's document prioritisation services and software, proprietary hosting and predictive coding solutions are available globally and can be deployed on-site.
- Production: High-volume capacity and a wide range of subject-matter expertise.

Managed Services

Managed Services offers a holistic, enterprise-wide approach to eDiscovery. It eliminates the need to shoulder the upfront costs of purchasing hardware and software. Epiq provides every capability needed to reliably perform eDiscovery.—software, hardware and processes—but most importantly, we provide the workflow management to make these capabilities work together. Epiq works with our clients to design a managed services package to suit their capacity and workflow requirements at a fixed monthly cost.

ArcSM is your own hosting environment for a fixed monthly fee: it eliminates the need for large, initial capital expenditures for hardware infrastructure or software licenses. The Arc platform includes unlimited use of email threading, near de-duplication, clustering and predictive coding. With Arc, a single dashboard provides administrative control over cases, users and security. Additionally, you get instant reporting on storage, users, custodians and attorney review speed and quality. Arc gives you one of the best review applications on the market at a predictable cost and without an upfront investment in hardware or software.

Professional Services

Our global consulting team offers expert services in discovery preparedness, litigation and practice support, litigation and dispute services, records management, early case assessment (ECA) and information governance. We also have expert services available in law department strategy and technology planning and implementation.

High-quality project management

Epiq offers best-in-class project management with more than 100 dedicated client support individuals working in a team-based environment. Epiq's project management and client services teams have extensive experience of supporting clients and their consultants and in aiding them with the development of new workflows for all elements of the eDiscovery process. Epiq assigns a committed project management team to the client to provide service consistency across cases and catalyse the development of cost saving, risk reducing standards of practice and case workflow.

Predictive Coding (TAR)

Alongside our deep technology expertise, Epiq provides best-in-class TAR solutions including Relativity Analytics, Equivio Zoom, and Brainspace. We support these with a team of 9 TAR consultants to ensure our clients achieve the best outcome from TAR workflows. All of the technologies we support have been defensibly deployed in cases in the jurisdictions of the UK, Ireland and the United States. For all projects we are able to provide a report describing the technologies deployed, the methodologies used, and an explanation of the results of the process. If required, we are able to provide expert testimony to support the technologies and processes used.

The technologies we support provide the following TAR capabilities:

- Predictive Coding (whether for review prioritisation or culling)

- Concept searching
- Categorisation
- Clustering
- Email threading
- Near duplicate analysis

Epiq Mobile Solutions

To facilitate eDiscovery services for our clients on a global scale, Epiq currently has operations in the following countries:

- Asia: Hong Kong, Japan, China, Singapore and India;
- Europe: UK, Germany, and Poland;
- North America: United States (multiple locations) and Canada;
- Australia

For services required outside of these areas, we can provide a mobile solution that will allow for a full range of eDiscovery needs without any data leaving the country. Support can be provided locally on a contracted basis, or supported remotely and our teams are experienced in providing mobile hosting and processing solutions that can be delivered in the requisite jurisdiction.

Our mobile solution is a server environment that can be deployed in-situ at client sites, with Epiq experts providing on-site assistance from the point of data collection all the way through to supporting document review. The portable server unit is air-gapped, with no ability to access a wider network, and can be hosted within any secure environment at a client's site. Our portable solution can also be deployed behind a client's firewall, and optionally integrated into their existing IT infrastructure. Our lead times for deploying our mobile solutions are dependent on various factors including on the country where the infrastructure will be deployed.

Epiq Document Review Services

Our document review services enable our corporate clients and/or their outside counsel to outsource to us some or all of the tasks associated with reviewing document collections in an eDiscovery project. This includes:

- Interviewing and hiring qualified legal professionals for limited-duration document review work.
- Providing guidance to the client's outside counsel regarding best practices throughout the review process. Examples include reviewing the document review protocol and coding form if requested.
- Providing review project management services.
- Providing technology training to the review legal professionals.

Epiq provides review services in our secure facilities in London and in Frankfurt, throughout the United States, Hong Kong, India, Tokyo, and Toronto. We have more than 1,900 seats available worldwide.

We make extensive use of a variable workforce for document review engagements and only bring on staff as projects commence. The review team may range from a few legal professionals to several hundred legal professionals at a time. We have provided review services for over 40 languages and for many different types of files e.g. audio and chat.

Document reviewers generally work from our secure document review rooms designed to protect the confidentiality of our clients' sensitive data. Our security measures extend to both the technical and physical environments (e.g., neither removable storage media nor printers are used in the review pods, no personal belongings are permitted in the review rooms).

Court Reporting

From Houston to Hong Kong, Epiq leverages cutting-edge technology and global resourcefulness to help you more efficiently manage your transcription needs.

More than 10,000 corporate and law firm clients draw on our vetted network of 5,000+ court reporters to generate north of 8 million pages of transcripts annually. As the legal process moves from complexity to clarity and through to finish, Epiq's resources and experience help you streamline your transcription requirements to save time, money and energy—night and day, around the world.

Real-time reporting

Real-time court reporting provides users with a live, verbatim record of legal proceedings as they happen. Text is sent directly to laptops in the hearing room so that users can annotate transcripts according to issues specific to their case. Users are also able to create customised searches and annotation reports across multiple hearing days, allowing all results to be consolidated into one document.

For complex proceedings involving multiple parties or large amounts of evidence, real-time is of particular benefit, especially where information needs to be shared with team members based in multiple locations:

- Reduce preparation and court proceedings time by up to 25 per cent
- Search, view and annotate transcripts
- Create reports of annotations and search results across transcripts

Real-time court reporting services are used in the world's most high profile cases and are available as a desktop or web-enabled version for access on laptops or iPads in the hearing room or remotely. Full training, technical support and equipment are provided throughout the lifecycle of a case.

Daily reporting

For shorter hearings, where you may not require real-time reporting but still need a transcript quickly, Epiq can produce a verbatim record of proceedings at the end of the day, usually within two to three hours.

Electronic Presentation of Evidence (EPE)

Electronic Presentation of Evidence refers to the in-court display of documentation, files, pictures, audio and graphics during trial, displayed onto multiple screens for all parties to view. The use of EPE aids counsel in delivering an effective and compelling presentation, and it is estimated that its use results in a saving of approximately one third of court time.

Epiq supplies all relevant hardware and software where EPE equipment is not already installed in the courtroom. An independent operator, provided for the duration of the hearing, will control the display of evidence using specialist trial presentation software, and annotate and enhance on-screen images in accordance with the parties' instructions. All EPE operators are carefully selected and provided with training to work efficiently and confidently in the often pressured environment of the hearing room.

8.1.33 Ernst & Young

Glenn Perachio Trevor Horwitz Tyrone Edward	
gperachio@uk.ey.com +44 (0) 20 7951 4628	
thorwitz@uk.ey.com +44 (0) 20 7951 9627	
tedward1@uk.ey.com +44 (0) 20 7951 6839	
1 More London Place, London, SE1 2AF	
www.ey.com/UK/en/Services/Assurance/Fraud-Investigation---Dispute-Services	
<p><u>Company Description</u></p> <p>EY has been providing services in the eDiscovery space for over two decades. We assist organisations prepare and respond in a timely, cost-efficient and defensible manner to litigation and regulatory obligations. The majority of our senior team has at least 20 years' experience in this field. The cumulative experience represented in this practice and across our allied practice areas, such as IT forensics, Data Analytics, Cybersecurity, Data Privacy and eDiscovery Advisory, is available to all our clients.</p> <p>We are a truly global firm with fully connected operations in more than 700 offices located in 150+ countries with local, same-language support provided by our 231,000 professionals for most situations.</p> <p>Our sector-oriented strategy aligns well with our clients' diverse businesses, bringing in subject matter resources with deep industry knowledge. We are committed to innovation and our emphasis is not only on being a thought leader in the eDiscovery space, but also on being execution leaders as practitioners who continually strive to improve leading practices and obtain better results for our clients.</p> <p>One other key area of differentiation is our continual improvement based on harnessing experience across clients around the globe and turning insight into actionable innovation which enhances client value. This relentless drive to improve based on real world situations has allowed us to deliver meaningful value to clients, often while reducing their costs.</p>	
<p><u>Vendor Offerings</u></p> <p>Identification, Preservation and collection of ESI</p> <p>Perform time-critical forensically sound data identification, preservation and collection activities globally and simultaneously, which is underpinned by tailored legal hold design, implementation and review based services.</p> <p>Computer forensics, data mining and analysis</p> <p>Detailed forensic analysis of computing platforms, smart devices and mobile hardware to reveal electronic facts about structured and unstructured data with robust evidentiary integrity, suitable for definitive investigatory or litigation conclusions.</p> <p>Managed Document Review</p> <p>Provide law firms and corporate legal departments with secure and scalable review facilities that are fully integrated with EY's proprietary review platform. Review staff consist of paralegals, fully qualified lawyers and investigators all focused on identifying relevance as guided by our clients'.</p> <p>Hosted Services</p>	

Provide our clients with a tailored, secure and scalable online review environment which is focused on injecting the right people, process and technology into an agreed methodology which contains the right level of flexibility to service our clients' needs. EY's hosting network also gives a truly global footprint, and allows us to make certain client data is held only within particular geographies – e.g. UK-only, EU, USA – to meet our clients' data protection needs. Where a particular localised requirement exists we can also deploy our mobile technology stack on clients' premises.

Structured Data Analytics

Mitigating the unforeseen and responding promptly within a legal environment is crucial. Our analytical tool set covers latent semantic indexing, text clustering and Bayesian classification, which aims to provide insight into the unknown. Also, we are able to construct custom tools to address tailored client requests.

Early case assessment

We offer the appropriate analytical technologies and supporting dashboards which enables our clients' to gain a timely understanding of the data landscape, associated with their matter. This allows focused decisions to be made from the outset that feeds into the objectives of the document review schedule.

Technology-Assisted Review (TAR)

We regard TAR as a series of document mining methodologies with the aim of improving review efficiency and cost effectiveness. Our application set covers predictive coding, text and document clustering and machine learning.

Managed Services

Act as provider of all or part of the eDiscovery process, taking away the challenge of day-to-day eDiscovery management. Our service provides end-to-end capability by integrating some or all of the above services from collection through to secure hosting, MDR and production.

EY has invested significantly in its core technology platforms, and we have supplemented off-the-shelf software with our own automation and advanced analytics capability. We have a large and highly disciplined development organisation that features dedicated quality control and over 4,000 software engineers, mainly in the US, India and Europe.

We have a network of global Managed Services delivery centres allowing us to provide global scale and flexibility, coupled with EY's in-depth expertise and technology. These capabilities allow both large and small clients to flexibly access EY's suite of eDiscovery services. Our deployment models enable everything from temporary capacity addition to long term, high volume activity and can leverage our global footprint to provide "follow-the-sun" services as well as dedicated in-country capability.

For document review we have invested in Relativity and have developed significant add-ons to increase our clients' involvement in and awareness of how their projects are being managed throughout their lifecycle. We host regular Relativity administrator training courses at our offices in London.

8.1.34 Everlaw

Chirag Zaveri	
chirag@everlaw.com +44 (0)7539 465843,	
70 Wilson Street London EC2A 2DB.	
www.everlaw.co.uk	
<p><u>Company Description</u></p> <p>History</p> <p>Everlaw was founded in the US in 2010, with the product first available on the market in 2011. Since the initial release, Everlaw has expanded its global footprint including availability in the UK beginning in 2017. Everlaw's software has been used by over 500 legal teams at law firms, corporations, and 100% of U.S. State Attorneys General.</p> <p>Mission</p> <p>Everlaw believes that legal teams deserve cutting-edge technology in their pursuit of justice. Our team of top Silicon Valley engineers is on a mission to replace antiquated, clunky, on-premises software with an integrated, elegant platform for litigating a case from discovery to the courtroom. Everlaw delivers a fresh experience through blink-speed search, an intuitive user interface, real-time collaboration, accessible predictive coding, and robust case-building tools.</p>	
<p><u>Vendor Offerings</u></p> <p>Everlaw is a collaborative, cloud-based litigation platform for in-house counsel, litigators and the government that enables teams to discover, reveal, and act on information to better drive internal investigations and positively impact the outcome of litigation.</p> <p>See software section for more details (8.2.22)</p>	

8.1.35 Exigent Group Limited

Matt Hoy	
mhoy@exigent-group.com +44 (20) 7101 0755	
118 Pall Mall, London SW1Y 5ED	
www.exigent-group.com	
<p>Company Description</p> <p>Exigent is a global alternative legal services provider operating at the intersection of law, data and technology. With a team of over 400 attorneys, business analysts, developers and consultants, we apply analytical thinking, smart use of technology and inventive talent to deliver answers that impact on every aspect of your business performance.</p> <p>Exigent's contract management solutions and business analysis tools help the C-suite, in-house counsels and law firms reduce risk, improve compliance and drive process and cost efficiencies.</p> <p>Exigent has eight offices globally with three operating centers in Bangalore, Cape Town and Perth.</p> <p>For more information, please visit us at: www.exigent-group.com</p>	
<p><u>Vendor Offerings</u></p> <p>LEGAL SERVICES</p> <p>Exigent's skilled legal professionals offer the support which corporate legal departments and law firms need so that their staff focus more hours on higher value tasks:</p> <ul style="list-style-type: none"> • legal services including contract review, due diligence, e-discovery and information governance, corporate compliance; • immigration; • medical legal services; • talent acquisition; and • outsourced legal administration. <p>Technology</p> <p>Exigent's technology solutions offer practical, powerful tools that, paired with the right people, turn data into a smart asset that can create opportunity and value that includes:</p> <ul style="list-style-type: none"> • contract management software; • business analytics software; • document creation software; and • legal spend and matter management software. <p>Consulting</p> <p>Exigent's experts understand your business. We combine powerful data tools with our expertise to give you actionable insights and guide you through how this information can answer the company's business needs.</p> <p>Our consulting services include:</p> <ul style="list-style-type: none"> • legal department optimization; 	

- legal spend analysis; and
- contract optimization analysis.

SOFTWARE:

Exigent Contract Management

Exigent Contract Management is a flexible, adaptable platform that helps manage and analyze contracts and related obligations. Our powerful software combines smart technology with experienced legal and commercial expertise to transform data into opportunity and value.

Key features:

- secure central contract repository;
- report generation and searchable repository;
- easy-to-use dynamic dashboards;
- compliance management that ensures your obligations are managed and tracked;
- lifecycle management that gives you a snapshot of the entirety of each contract, highlighting important dates;
- management of contract terms by transforming unstructured legal data into actionable data; and
- contract version control and permissions-based access control.

Key benefits

- Improved revenue and reduced costs in the short and longer term.
- Increased efficiency and quality.
- Mitigate risk and convert residual risk into value.
- Streamlined internal operations and increased understanding of revenue streams and sources of revenue leakages.
- Improved management of commercial contracts and visibility of compliance with regulatory obligations.
- Continuity of business with timely notifications and alerts for upcoming deadlines and obligations.

Business analytics software

Exigent's business analytics software is a powerful, web-based, on-demand analytics solution that analyses extracted contract data to create meaningful interactive reports and dynamic integrated dashboards. These reports share business intelligence and insights directly to your desktop, tablet or smartphone anytime, anywhere, to key stakeholders in your organization.

Key features:

- speed of analysis;
- interactive data visualization;
- visual discovery;
- architecture agnostic;
- real-time collaboration; and

- centralized data.

Key benefits

- Powerful reports are specifically designed to capture granular information in the complex contracts and the inter-relationships which enable smart decision-making.
- Monitor contract milestones and risk markers, easily locate and search for terms and study trends across all your contracts, helping to quantify the contract value.
- In a crisis, quickly access the key information management needs to determine a course of action.
- To better discover, analyse and act on contracts throughout the organization to improve performance and agility, while reducing risk and cost.
- Enable deeper insights and discover business challenges, thus improving procurement efficiency, developing marketing strategies and supporting business growth.

Document creation software

Exigent's document creation software is an easy-to-use generation and automation tool, ideal for simple agreements, NDAs and other legal documents, enabling the creation of accurate, timely, and compliant documents, letters, and contracts that merge organization's approved clauses. The tool is customisable and adaptable to specific requirements.

Key features-

- template-based contract creation;
- intuitive wizard to capture customized information;
- manage multiple templates and document versions;
- enables the user to send out appropriate document out for e-signature through the system;
- role-based access;
- system reporting;
- basic search functionality; and
- integration with obligation management system.

Key benefits-

- Operational efficiency: accelerated speed to build standard contracts.
- Risk reduction: transform the most complex documents into intelligent, interactive templates allowing document authors to control the data used to populate and generate customised documents.
- Enhanced compliance: internal compliance and external regulation can be applied as part of the template creation process, ensuring that all documents generated automatically conform to an organisation's governance procedures.
- Management of contracts: the generated contracts can be stored in the obligation management system, allowing an organization to have full control of its contracts.

Legal spend and matter management software

Exigent's legal spend and matter management software comprises three platforms: a matter management system which allows businesses to track and manage their legal matters online; an e-billing system for external vendors, which allows tracking of legal spend and provides the business with accurate spend analytics; and an administrative platform which allows site administrators to perform high-level site maintenance. The cloud-based system is designed and built with the sole purpose of improving the way corporate businesses manage legal matters and pave the way for true legal insights and spend analysis.

Features:

Matter management:

- full administrative control for customization and maintenance;
- matter versioning;
- time recording;
- creation of instructions to external vendors;
- user type-based dashboards;
- spend, rebate and matter reports;
- oversight over business;
- invoice auditing to check for discrepancies in billing;
- tasks for managing the predefined invoice process;
- dashboards for accounts users to manage their tasks; and
- automated predefined tasks for efficient turnaround times on invoicing.

E-billing:

- invoice submission;
- credit note submission;
- invoice search;
- user alerts;
- checks if an invoice has already been submitted;
- marks instruction as closed once a final invoice is submitted;
- notifies user of rejected invoices that need to be credited;
- lists active instructions with essential billing information; and
- displays invoicing rules specific to each client's requirements.

Benefits:

- improved control and overview of legal matters;
- reduced work load and improved team efficiency (reduce internal costs);
- improved relationship with legal service providers (improves collaboration);
- reduced legal spend;
- increased rebates; and
- advanced data security.



8.1.36 Exterro UK Limited

James Thompson	
James.thompson@exterro.com 0333 939 8849	
Tower Bridge House, St Katharine’s Way, London E1W 1DD	
www.exterro.com	
<p><u>Company Description</u></p> <p>Exterro was founded in 2004 with the simple vision that applying the concepts of process optimization and data science to how companies respond to litigation would drive more successful outcomes at a lower cost. With software solutions that span the full e-discovery lifecycle and support information governance initiatives, Exterro helps some of the world’s largest organizations work smarter and more efficiently.</p> <p>The Preferred Choice of the Fortune 500</p> <p>60% of Exterro’s clients belong to the Fortune 500 and include such notable brands as Barclays, AstraZeneca and Siemens. These discerning global companies rely on Exterro to meet their unique and complex e-discovery and information governance requirements. Our clients extend across every major industry, including the healthcare, finance and energy sectors.</p> <p>A Recognized Market Leader</p> <p>Exterro is recognized by industry analysts as one of the top software providers in the market. Among other industry recognitions, Exterro was positioned in the Leaders Quadrant in Gartner’s Magic Quadrant for E-Discovery Software in 2013, 2014 and 2015 and is ranked in the current Leaders Quadrant in G2 Crowd.</p> <p>Extensive Partner Network</p> <p>Exterro partners with a variety of leaders in the legal technology and service provider/consulting industries. Technology partnerships in areas like matter management, HR systems, archive solutions and other content repositories enable Exterro customers to utilize previous investments while still integrating next-generation Exterro technology. Service and consulting partnerships allow users to leverage proven e-discovery experts to successfully implement and manage Exterro’s software.</p>	
<p><u>Vendor Offerings</u></p> <p>Exterro Orchestrated E-Discovery enables customers to manage, measure, and optimize e-discovery processes, unifying all e-discovery phases and all internal and external stakeholders on the same technology platform. Information is available anytime, from anywhere. The result is that clients are able to defensibly complete the e-discovery process in far less time and at a much lower cost.</p> <p>Exterro software solutions that can be deployed on premise or in the cloud:</p> <ul style="list-style-type: none"> • EXTERRO DATA MAPPING • EXTERRO LEGAL HOLD • EXTERRO OFFICE 365 EXPLORER • EXTERRO E-DISCOVERY DATA MANAGEMENT (ECA / COLLECTION / PROCESSING / REVIEW/PRODUCTION) • EXTERRO PROJECT MANAGEMENT • EXTERRO EMPLOYEE CHANGE MONITOR • EXTERRO FILE ANALYSIS 	

8.1.37 FRP Advisory

Steven Jones	
Steven.Jones@frpadvisory.com	
110 Cannon Street, London, EC4N 6EU	
www.frpforensics.com	
<p><u>Company Description</u></p> <p>FRP Advisory (“FRP”) is a business services firm providing restructuring and insolvency services, pension advisory, corporate finance, and forensic accounting and technology services.</p> <p>The firm was formed in June 2010 and has approximately 300 staff and over 45 partners. The business is a limited liability partnership owned by its partners.</p> <p>Our Forensic Services team are highly experienced forensic accountants and forensic technologists, working closely together to provide a full-service offering. We are instructed to provide independent, objective advice in the context of investigations and disputes.</p>	
<p><u>Vendor Offerings</u></p> <p>FRP offer services across the entire electronic disclosure process, from assistance with data mapping and identification, through forensic data capture, document review and disclosure. Consultancy is central to our approach, whether providing services internally to assist with investigations, or proactively working with clients to assess the most cost-effective approach for each case.</p> <p>Drawing on many years of experience of capturing data from a variety of friendly and hostile environments, the collections team at FRP ensure that the correct protocols are followed such that the process will stand up in court if required. We also have the skills to carry out in-depth forensic investigation of devices.</p> <p>Our team have worked on cases ranging from Subject Access Requests containing a few thousand documents, to multi-million document, multi-jurisdictional cases. The web-based interface of our document review tool, Relativity, provides access rapidly, while two-factor authentication and trusted IPs offer peace of mind that data security is at the forefront of our service. Our knowledge of Relativity is underpinned by the certifications held by our team, including Relativity Certified Administrator, Analytics and Processing.</p> <p>Once a document review is complete, we can create bespoke disclosures to a variety of regulators, government agencies and other third-party providers.</p>	

8.1.38 FTI Technology (A practice of FTI Consulting)

<p>Matthew Madrigale (Director)</p>		
<p>matthew.madrigale@fticonsulting.com</p>		
<p>D: +44 (0) 20 3727 1331</p>		
<p>M : +44 (0) 7912 552 593</p>		
<p>200 Aldersgate, Aldersgate Street, London, EC1A 4HD</p>		
<p>www.ftitechnology.co.uk</p>		
<p><u>Company Description</u></p>		
<p>FTI Consulting, Inc. is a global business advisory firm dedicated to helping organisations protect and enhance enterprise value in an increasingly complex legal, regulatory and economic environment. With more than 4,600 employees located in 28 countries as of January 2018, FTI Consulting professionals work closely with clients to anticipate, illuminate and overcome complex business challenges in areas such as investigations, litigation, mergers and acquisitions, regulatory issues, reputation management, strategic communications and restructuring.</p> <p>FTI Technology solves data-related business challenges, with expertise in legal and regulatory matters. As data grows in size and complexity, we help organisations better govern, secure, find, analyse and rapidly make sense of information. Innovative technology, expert services and tenacious problem solving provide our global clients with defensible and repeatable solutions. Organisations rely on us to root out fraud, maintain regulatory compliance, reduce legal and IT costs, protect sensitive materials, quickly find facts and harness organisational data to create business value.</p> <p>More information is available at www.ftitechnology.co.uk.</p>		
<p><u>Vendor Offerings</u></p>		
<p>Our complete range of offerings, from forensic data collection to managed document review services, provides unprecedented flexibility to address any discovery challenge with confidence. Clients rely on our software, services and expertise to address matters ranging from internal investigations to large-scale litigation with global e-disclosure requirements. These include:</p> <p>Collections and Computer Forensics: We help organisations meet requirements for collecting, analysing and producing data from a variety of sources, including e-mail, voicemail, backup tapes, social media, the cloud, shared server files and databases—often on multiple continents. We provide both proactive and reactive support using expert services, and defensible methodologies and tools that help companies and their legal advisers understand technology-dependent issues.</p> <p>Ringtail® E-disclosure Software: A complete and easy-to-use e-disclosure and document review platform, Ringtail delivers defensible, cost effective review with advanced analytics, visual document review and predictive coding, unparalleled scalability and robust production capabilities. And with flexible workflows, nuanced security controls, intelligent reuse of data and multiple deployment options, Ringtail is as easy to manage as it is to use.</p> <p>Relativity: We are a leading UK provider of RelativityOne, a scalable and secure version of Relativity. It is open and customisable, can be accessed from anywhere via a standard web browser, and is supplemented by applications built by our in-house development team. Our offering is at the front of the market as the most supported and developed version of Relativity by the vendor, and this ensures that our clients have</p>		

access to the most up-to-date technology and the largest selection of tools available for their case.

Predictive Discovery: Predictive Discovery is a service offering that combines legal expertise, statistical quality assurance and advanced technology in one comprehensive solution. It provides you with the benefits of predictive coding technology and the confidence that the project will be completed in a cost-effective and defensible manner. In February 2016, the UK courts gave first judicial approval for the use of predictive coding in e-disclosure. This landmark decision could impact e-disclosure costs and proportionality arguments and increase the willingness of legal teams to use predictive coding in document reviews as part of a wide range of disputes and investigations.

Managed Review: With our managed review offering, you can meet deadlines, stay within budget, and trust the quality of the review. Our managed review offering ensures that you can seamlessly scale to handle any matter with high-quality review lawyers, using expert workflow and advanced technology. We offer a comprehensive managed review service from our site in Moorgate, centrally located in London.

E-disclosure Management: Our managed services reduce costs, provide greater budget predictability and transparency while reducing the need for internal technology investments. Through a master data repository, materials are processed once then can be used across multiple matters, enabling the reuse and retention of valuable work product such as privilege calls.

Consulting: We work with our clients to develop strategic programmes which are designed to reduce enterprise risk while improving the daily flow and management of critical information. We help our clients carry out a defensible and robust process for e-discovery that focuses not only on the technical tools, but also on the policies and procedures that support the process. Our team assist clients in managing any or all phases of the discovery lifecycle from identification through to production.

Information Governance: We assist in developing, implementing and delivering information governance projects that reduce corporate risk, cut storage costs, secure data, improve the e-discovery process and enable faster and deeper insight into data. Our services are tailored to meet specific client needs, whether you need a trusted adviser to assist with evaluating a new technology, a quick data migration project or a complete transformational service.

Radiance: An easy-to-use, scalable platform that allows organisations to connect, enrich, analyse and visualise millions of documents from disparate sources in a single, elegantly designed user interface. With a powerful search engine and a library of advanced visualisations – including social networking, communication patterns, concept clustering and timelines – Radiance can help organisations in a number of ways, including investigations, early data assessment and the identification of high-risk data, such as personally identifiable information. Radiance provides a natural complement to our Ringtail legal review software.

Forensic Data Analytics: We maximise analytics to help underpin investigations as it can paint a more accurate picture. Deploying statistical techniques, formulating bespoke algorithms and utilising machine learning are all forms of analytics we utilise to help digest and unravel large volumes of data far more accurately and efficiently. The techniques deployed also provides a forensically sound approach and the methods are defensible on large-scale investigations.

Cybersecurity: Our offering focuses on the full spectrum, from proactive privacy/security to reactive investigation and post-incident recovery. We have world-class professionals with leading experience

at the highest levels of government and law enforcement who have complementary skillsets and work as a single unit to benefit our clients.

Contract Intelligence: Due to the critical importance of contracts, a growing number of organisations are modernising their approach to these vital documents with FTI Technology's Contract Intelligence service. Providing a cost-effective solution for a key component of contract lifecycle management, Contract Intelligence helps organisations better find, understand and act upon contracts to meet regulatory requirements, reduce risk and recognise greater business value. FTI Technology does this by combining leading-edge analytics technology, advanced workflow, and attorneys experienced in reviewing contracts.

Software License Compliance & Optimisation: FTI uses a structured and strategic approach towards license compliance by improving processes, reducing license miscalculations and driving predictive revenue through greater insights. We offer 4 key services depending on client requirement; Compliance assessment, Procurement Consulting, Dispute Advisory and Crisis Management License Optimisation. In addition to the above services, FTI also has its own enhanced delivery model and in-house add-on tools for deep-dive compliance insights into licensing of high-risk software publishers like Oracle and SAP.

8.1.39 Grant Thornton UK LLP

Paul Wilson	
paul.r.wilson@uk.gt.com , +44 (0) 20 7 865 2719	
30 Finsbury Square London EC2P 2YU	
www.grant-thornton.co.uk	
<p><u>Company Description</u></p> <p>What starts out as an investigatory or regulatory problem very quickly becomes a hunt for information – who said what to whom, where that information is located and how to keep control of it when it can be moved around internationally, indiscriminately and at lightning speed. So how can lawyers, investigators and regulators make business decisions when the one piece of potentially critical information that they need is buried within a myriad of growing and disparate electronic data sources?</p> <p>Grant Thornton is one of the world's leading organisations of independent advisory, tax and audit firms. More than 42,000 Grant Thornton people, across over 130 countries, are focused on making a difference to clients, colleagues and the communities in which we live and work.</p> <p>In the UK, we are led by more than 185 partners and employ 4,500 of the profession's brightest minds to provide our clients with access to considerable sector knowledge and expertise. We provide assurance, tax and specialist advisory services to over 20,000 privately held businesses, public interest entities and individuals nationwide.</p> <p>Our Digital Forensics teams are led by experts in their art, including a qualified barrister and solicitor with years of experience leading complex digital forensic and electronic investigations. Our team were invited to join the 2017-2018 Disclosure Working Group, with Grant Thornton helping to co-author CPR 31 on Disclosure Protocols and electronic evidence handling. Others in our team have worked to investigate and prevent national cyber-terrorist incidents, helped to build and lead the Royal Military Police computer forensic investigation capabilities, and operated in law enforcement. We have experience of processing and hosting material for investigations before the SFO, FCA, CMA and ICO amongst other courts and regulators.</p> <p>Grant Thornton's Digital Forensics Group offers computer forensic support to all of our service lines, ensuring that all data is handled with appropriate chain of custody processes and to the highest standards within our ISO 27001 certified laboratories. Our global reach and forensic technology centres across Europe, America and Asia ensure we are well placed to deliver on multi-jurisdictional cases or where knowledge of local regulations is required. Our team can be engaged in conjunction with an expert witness, as part of a wider investigation appointment or as a stand-alone engagement.</p> <p>The team uses a combination of industry proven and state of the art technologies to handle and restore data from all manner of hardware systems, including computers, mobile telephones and embedded devices, and software and database systems including defensible transformation of structured and unstructured data.</p> <p>Our Computer Forensics team sits along-side our Electronic Discovery team ensuring that there is seamless integration between electronic evidence handling and data processing, enabling both teams to address challenging data types such</p>	

as encrypted material or partially corrupt or deleted data that can be restored to an evidential standard.

With data review being the single largest cost in any investigation or litigation support process, our Digital Forensics team can ensure that time is spent focusing on only the most critical information – **reducing volumes, review time and cost** - with the ultimate aim of assisting our clients in achieving the desired result.

Vendor Offerings

Our computer forensics and eDisclosure team provide assistance to clients on a wide variety of reactive litigation, investigation and regulatory compliance matters as well as proactive risk mitigation reviews. When faced with locating, preserving, searching and reviewing often vast quantities of data from disparate sources, our experts can assist and adhere to the core ethos that it is not simply the tools and technologies used to support the process, but the manner in which they are supplied which can truly make the difference.

Computer Forensics

Grant Thornton's dedicated Cyber Incident Response team is available 24 hours a day to investigate and contain data breaches and cyber-attacks. We have years of experience responding to breaches in international banks, critical national infrastructure, cross-jurisdictional crises including WannaCry and (Not)Petya, and investigating and inoculating cyber-attacks and malware within the NHS, universities, schools and corporates of all sizes.

Our Digital Forensics teams use a combination of industry standard tools including Relativity, NUIX, Veritas and F-Response, and unique and custom built hardware and software solutions to permit us to process and interrogate data at speeds up to 1,000 times faster than conventional technologies. Our technologies include machine language translation of most written and electronic media and solutions for transcription and sentiment analysis of audio data in English and other languages. In addition, we have specialist tools and expertise to process any form of accounting and financial database in to forms that can be interrogated for anomalies and fraud.

Grant Thornton's Digital Forensics team also supports and is supported by the largest team of dedicated asset tracing specialists in the UK, allowing us to offer end to end solutions in the investigation of a fraud including collection and processing of electronic evidence, managed reviews by subject matters experts in the commission of fraud, and dedicated experts able to trace and recover assets internationally. **We provide consultancy on block-chain asset-tracing and forensics on cryptocurrency wallets.**

Our solutions make use of best of breed technology and our services are fully UKAS ISO/IEC 27001:2013 security certified, providing our clients with the confidence that their **data will be handled and stored securely and sensitively.**

eDisclosure Services

We provide secure hosted eDisclosure solutions and consultancy advice which enables our clients to perform early case assessment, simple and complex searching, data analytics, review, redaction, categorisation and production of data in line with their matter specific requirements. Our team includes ten RCA accredited Relativity administrators, along with extensive experience, skill and knowledge of other eDiscovery platforms. Blending our experience, technical knowledge and solutions enables our clients to quickly and effectively reduce the volumes of data which may be subject to full review down to that which is deemed relevant to the matter in hand. This invariably **saves both time and cost.**

Our services allow for electronic data received from our clients or collected by our computer forensics experts to be fully processed, de-duplicated, filtered and indexed. Data is presented within user-friendly and feature-rich, web-based interfaces which require minimal training and allow our clients immediate access to search, analyse and review their data. In built functionality includes a host of data and text analysis tools for email threading, near duplicate detection, clustering, conceptual searching and computer/technology assisted review (TAR).

With paper documents still a factor in some cases, we also offer document scanning and coding services to present original paper material alongside any electronic data within the same eDisclosure platform.

Technology

We work with our clients to discuss their requirements in order to select the best solution for each matter. Our team makes use of a range of market leading and best of breed eDisclosure and Forensic software as mentioned above. We also employ other specialist redaction and translation/transcription tools such as Blackout and Systran.

In addition our experts use the best solutions available for forensic acquisition and analysis, including Access Data Forensic Toolkit (FTK); Guidance Software EnCase; and a host of **cutting edge** utilities, tools **and artificial intelligence platforms** to meet the particular needs of our clients.

8.1.41 HaystackID (US)

Hal Brooks, CEO	
+1-678-733-4184 hbrooks@haystackid.com	
1100 17 th Street, NW, Washington, DC	
HaystackID.com	
<p><u>Company Description</u></p> <p>Founded in 2010, HaystackID is a specialized eDiscovery services firm that helps corporations and law firms find, listen, and learn from data when they face complex, data-intensive investigations and litigation. With an earned reputation for mobilizing industry-leading computer forensics, eDiscovery, and attorney document review experts, HaystackID’s Forensics First, Early Case Insight, and ReviewRight services accelerate and deliver quality outcomes at a fair and predictable price.</p> <p>Serving more than 500 of the world’s leading corporations and law firms from North American and European locations, HaystackID’s combination of expertise and executional excellence coupled with a culture of white glove customer service make it the <i>alternative legal services provider</i> that is <i>big enough to matter but focused enough to care</i>.</p>	
<p><u>Vendor Offerings</u></p> <p>With an extensive portfolio of services customized for your specific needs, HaystackID can help you achieve quality outcomes at a fair and predictable price through the use of our Forensics First, Early Case Insight, and ReviewRight Services.</p> <p>Forensics First Services help you find your data during investigations and litigation.</p> <ol style="list-style-type: none"> 1. Computer Forensic Collections and Analysis 2. Computer Forensic Expert Witness Testimony 3. ESI Identification, Collection and Preservation 4. ESI Triage Services 5. Data Discovery Consulting and Management (Compliance, Information Governance, Computer Forensics) <p>Early Case Insight Services help you listen to your data to gain insight for data and legal discovery decisions.</p> <ul style="list-style-type: none"> • ESI Ingestion and Processing • ESI Assessment and Analytics • ESI Hosting • Managed Services • Legal Discovery Consulting and Management <p>ReviewRight Services help you learn from your data to make the right decisions for positive and quality investigation and litigation outcomes.</p> <ul style="list-style-type: none"> • ReviewRight Match (Reviewer Qualification and Sourcing) • ReviewRight Translate (Foreign Language Review) • ReviewRight Manage (Managed Review) • ReviewRight Host (Review Hosting) 	

- ReviewRight Automate (Technology-Enhanced Review)
- ReviewRight Virtual (Secure Remote Review)

These services are enabled and augmented by a combination of best-of-breed and proprietary technologies to support your technology requirements.

Core Software Platforms

- **Relativity:** Industry-leading eDiscovery and review hosting platform.
- **Brainspace:** Industry-leading analytics platform.
- **Nuix:** Industry-leading compliance and eDiscovery platform.
- **ReviewRight:** Proprietary software and database designed to streamline the assessment and selection of document review contract attorneys.

Core Software Enablers

- **DataThresher:** Proprietary interface designed to streamline culling in industry leading eDiscovery processing and analytics platforms. (Interoperability with Relativity and Brainspace)
- **Electronic Common Technical Document (eCTD) Review Module:** Proprietary review module designed to preserve the integrity and security of files being considered as part of complex regulatory reviews typically associated with FDA audits, investigations, and reviews. (Interoperability with Relativity)
- **Relativity Celebrite Integrator:** Proprietary tool that streamlines fact harvesting of unstructured data formats from mobile devices and enables extracted data to be searched, reviewed, and produced within an industry standard review and document production workflow.
- **Technology-Enhanced Review:** Proprietary combination of technology and processes designed to streamline technology-assisted review and predictive coding.

8.1.42 Heureka Software, LLC (US)

Nate Latessa	
nate.latessa@heurekasoftware.com +1 888-968-7199,	
1382 W. 9 th Street, Suite 410S Cleveland, Ohio USA 44113	
www.heurekasoftware.com	
<p><u>Company Description</u></p> <p>Over ninety percent of today's corporations have no idea where their data is located, or the contents contained within terabytes of data stored on file servers and computer workstations. Computers and servers are overflowing with information that has been collecting for years. This ever-growing data collection contains valuable and sensitive information such as intellectual property or information that is legally required to remain private, making your environment target-rich for data theft.</p> <p>Founded in 2014, Heureka Software provides real-time access to unstructured data on network file systems, servers, VM's, laptops and desktops from a single user interface and provides search and risk intelligence along with tools to collect, quarantine or delete files enterprise-wide.</p>	
<p><u>Vendor Offerings</u></p> <p>Risk and Compliance</p> <p>Heureka's daily indexing and categorization engine helps locate and tag risky information such as national identification numbers as well as bank routing or credit card data. Heureka helps quantify risk and increase business resiliency by finding and eliminating data with no business, legal, or regulatory value. Reports allow you to audit and verify data content while file actions allow you to collect, quarantine or delete files helping to enforce policy or regulatory rules across an enterprise.</p> <p>E-Discovery</p> <p>Heureka is the Earliest Case Assessment tool on the market by allowing users to search and analyze data in-place, on each Heureka-installed endpoint and provides the ability to surgically collect only the files required. Heureka eliminates the need to over-collect and process data and provides the ability to collect information regardless of geographic location.</p> <p>Heureka provides a full suite of search capabilities from keywords and Boolean queries to hash values, dates, file extensions or file names. Once located, files can easily be exported to common E-Discovery platforms such as Relativity, Zapproved or XERA-iCONNECT for full legal review and tagging. Best of all, Heureka provides <i>shared intelligence</i> to outside platforms so that knowledge gained with Heureka travels with each document along the E-Discovery path.</p> <p>GDPR</p> <p>Heureka helps organizations comply with the European Union General Data Protection Requirements (GDPR). Heureka is uniquely capable of responding to Subject Access Requests by providing a rapid, enterprise wide search capability from a single interface. Files and indexes remain in place on each endpoint with tools to delete or quarantine files if necessary. On-premises deployment options maintain privacy within an organization.</p>	

8.1.43 Hillogic (Australia / UK)

Rick Hill (Director)	
rick.hill@hillogic.com	
Head office: Level 14, 333 George St, Sydney NSW 2000, Australia London: Level 17, Dashwood House, 69 Old Broad Street, London, EC2M 1QS	
www.hillogic.com	
<p><u>Company Description</u></p> <p>Hillogic is a full service software company specialising in eDiscovery tools and web applications. With over 30 years experience in a wide range of technologies, we develop software solutions, integrate software technologies and take advantage of the latest developments and trends in web technology</p> <p>Our team has deep knowledge of legal and financial services specialising in eDiscovery technologies, CRM systems and financial software solutions.</p> <p>At Hillogic, we're dedicated to evolving your business through innovation. We strive to improve our client's business process with creative solutions and efficient technologies.</p>	
<p><u>Vendor Offerings</u></p> <p>Relativity Applications – We have developed a number of Relativity applications and utilities for Relativity partners to assist in making the review workflow more efficient.</p> <p>Automation - We love to automate processes and integrate different technologies for seamless workflows</p> <p>Web design and digital marketing - Our expert team design and build websites and web applications which integrate into other existing technologies. Our web services also include SEO to optimise online presence with social media and search engine marketing.</p>	

8.1.44 IBM United Kingdom Limited

Amir Jaibaji (Program Director, Offering Management)	
ajaibaji@us.ibm.com +512.417.7654	
IBM South Bank, 76 - 78 Upper Ground, South Bank, London SE1 9PZ	
www.ibm.com	
<p><u>Company Description</u></p> <p>IBM is a global technology and innovation company headquartered in Armonk, NY. It is the largest technology and consulting employer in the world, with more than 400,000 employees serving clients in 170 countries, with around 20,000 of these in the UK, bringing innovative solutions to a diverse client base to help solve some of their toughest business challenges.</p> <p>IBM offers a wide range of technology and consulting services; a broad portfolio of middleware for collaboration, predictive analytics, software development and systems management and the world's most advanced servers and supercomputers. In addition to being the world's largest IT and consulting services company, IBM is a global business and technology leader, innovating in research and development to shape the future of society at large. IBM's prized research, development and technical talent around the world partner with governments, corporations, thinkers and doers on ground breaking real world problems to help make the world work better and build a smarter planet.</p> <p>In the era of big data, sifting through massive amounts of information to uncover what is important to a litigation matter is not only time consuming, but it increases cost and risk. eDiscovery solutions from IBM streamline the eDiscovery process for legal stakeholders and aligns them with IT, providing faster insight into data and ensuring only the right information is collected. IBM believes that eDiscovery starts with a solid information governance foundation, saving you time and money and reducing risk in the long run.</p>	
<p><u>Vendor Offerings</u></p> <p>IBM StoredIQ for Legal</p> <p>StoredIQ for Legal enables legal teams to gain visibility and control over their eDiscovery/eDisclosure process reducing manual steps and handoffs resulting in reduced errors, time and cost. By providing a precise, swift, thorough and highly scalable solution for legal hold management, data identification and collection it helps them deliver a reliable, repeatable and defensible process for improved, timely and cost-effective legal outcomes.</p>	

IBM and the IBM logo are trademarks of International Business Machines Corp., registered in many jurisdictions worldwide.

8.1.45 Iconic Translation Machines

Stephen Davis, Sales Director	
+44 (0) 7957 804 594 stephen@iconictranslation.com	
Capital Office Kemp House 152-160 City Road, London EC1V 2NX	
http://iconictranslation.com	
<p><u>Company Description</u></p> <p>Iconic Translation Machines (Iconic) is a language technology software company. We have clients across a range of industries served from our London and Dublin offices. Founded in 2012 we have assembled a world-class team that is taking more than a decade’s worth of leading research and development into Machine Translation and language technology and bringing it to our partners in an easy to use, secure, cost-effective manner.</p> <p>We partner with the world’s largest enterprises, law firms, and government organizations, helping them to adopt bespoke, secure Neural Machine Translations solutions to deliver and consume multilingual content for their business.</p> <p>Iconic’s e-discovery solution, using proprietary Neural Machine Translation (NMT) software, can help e-discovery providers, law firms, and corporate legal departments to translate large quantities of foreign language ESI, quickly, securely, and effectively.</p> <p>Iconic’s translation solutions for e-discovery have been seamlessly integrated and leveraged extensively in the legal industry. All services are hosted in top-tier cloud-computing facilities, ensuring maximum information security. The translation service is accessible through Iconic’s secure online translation portal, on-premise server solutions, or third-party application connectors such as Relativity.</p> <p>Iconic has pioneered automated translation solutions tailored to cross border legal cases. Our e-discovery solutions are secure and robust, providing faster, more effective streamlined review of foreign language information.</p>	
<p><u>Vendor Offerings</u></p> <p>Iconic’s e-discovery translation software allows you to translate vast amounts of foreign language ESI quickly, securely, and effectively, without having to move files in and out of your review platform. We empower you to search for and find the most relevant documents in your multilingual content, in your language.</p> <p>With proven technical excellence in the development and deployment of legal translation software solutions, Iconic’s proprietary software enables better quality end-to-end legal translation solutions that can be further adapted to your legal case by our in-house expert team of technologists using proprietary language tools.</p> <p>Capabilities</p> <ul style="list-style-type: none"> • Proprietary technology: Innovative, state-of-the-art, proprietary architecture based on neural networks and artificial intelligence means more effective translations for review, reducing the risk of missing critical information. • Compatibility: Iconic Relativity App is fully compatible with Relativity and RelativityOne, the cloud version of the e-discovery platform. 	

- **Broad language coverage:** Machine translation in more than 50 languages and 2,000 language combinations means the vast majority of cases are covered.
- **Automatic language Identification:** Automatically detect the languages of your data set so you can focus on the review at hand—in your language.
- **Native file translation:** Native file formats including Microsoft Office (Word, Excel, PowerPoint), emails, PDFs, and text.
- **Translation customization:** Further adapt translations to your legal case, content, or industry with custom enhancements—including terminology and glossaries—for even more accurate translations.
- **Robust, scalable:** Translate large volumes of documents in a fraction of the time.
- **Secure, confidential:** Our private cloud solutions are secured using certified SSL technology, and our on-premise solutions ensure your data never leaves your network, preventing information leaks.
- **Data protection:** Our servers are located in multiple jurisdictions, meaning you can control where your data resides depending on the requirements of your clients.

Chapter 8 – Supplier & Software Details

8.1.46 i-Lit Limited & i-Lit Paralegals Ltd

<p>Mike Taylor (Managing Director)</p> <p>MTaylor@i-lit.co.uk, 01748 810221</p> <p>Rushwood House, Richmond, North Yorks, DL10 6BG</p> <p>www.i-lit.co.uk</p>	
<p><u>Company Description</u></p> <p>Founded in 2006 i-Lit Limited provides independent e-disclosure training, project scoping, vendor procurement and project management services to law firms. Mike Taylor of i-Lit Limited is recognised as one of the UK's leading e-disclosure experts who regularly writes on advances in law and technology.</p>	
<p><u>Vendor Offerings</u></p> <ul style="list-style-type: none"> • Scoping e-disclosure exercises. • Drafting e-disclosure protocols. • Completing e-disclosure Questionnaires. • Procuring external service provider support. • Advising on communications from other parties. • Project Management. • Training. 	

i-Lit Paralegals Limited

<p>Mike Taylor (Managing Director)</p> <p>MTaylor@i-litparalegals.co.uk, 01748 810221</p> <p>Rushwood House, Richmond, North Yorks, DL10 6BG</p> <p>www.i-litparalegals.co.uk</p>									
<p><u>Company Description</u></p> <p>Founded in 2010 i-Lit Paralegals Limited provides temporary document review staff to law firms and companies. Uniquely focussed on the document review industry i-Lit Paralegals provides staff throughout the UK and Europe to organisations who need to effectively and efficiently review large quantities of documents.</p> <p>We are "review platform agnostic" and can provide staff experienced in the sector of your review, in the software you are using and who speak the same languages as the document population.</p> <p>Our minimum educational requirement is the successful completion of the LPC although we regularly supply teams of fully qualified staff. Our service is focussed on quality and is bespoke on every occasion and as such we are used to delivering the most demanding of client requirements.</p> <p>We price on either an "hourly" pricing model, a "per document" pricing model which just covers review or a "per document" pricing model that covers project scoping, data processing and document review.</p>									
<p><u>Vendor Offerings</u></p> <table style="width: 100%; border: none;"> <tr> <td style="width: 50%;">On Site Review</td> <td>Off Site Review</td> </tr> <tr> <td>Managed Review Services</td> <td>Document Review</td> </tr> <tr> <td>Review Management</td> <td>Workflow Management</td> </tr> <tr> <td>Technology Assisted Review</td> <td></td> </tr> </table>		On Site Review	Off Site Review	Managed Review Services	Document Review	Review Management	Workflow Management	Technology Assisted Review	
On Site Review	Off Site Review								
Managed Review Services	Document Review								
Review Management	Workflow Management								
Technology Assisted Review									

8.1.47 Innovative Development LLC (IDLLC UK Ltd) LLC

Richard Slawter	
Richard.Slawter@id-llc.com +1 215-230-4130	
5 New Street Square, London, EC4A 3TW.	
www.idediscovery.com	
<p><u>Company Description</u></p> <p>Founded in 1992 Innovative Development has been providing eDiscovery services since 2007. Innovative Development’s team of eDiscovery specialists provides state-of-the-art support to help clients facing the challenges of collecting defensible electronic information. Our UK office provides support for our international clients in Europe and Africa. This includes the newest EU regulation, GDPR (General Data Protection Regulation) which seeks to create a harmonised data protection law framework across the EU giving citizens back the control of their personal data.</p> <p>Innovative Development is enhancing it’s eDiscovery services to include advanced A/I concepts and machine learning. Working with advanced collection, processing and review tools (we are tool agnostic) to conceptualized data and create efficient eDiscovery business process which will accelerate the completion of all compliance and litigation tasks on time and within budget.</p>	
<p><u>Vendor Offerings</u></p> <p>Innovative Development focus is multi-national companies facing a myriad of compliance and legal responsibilities that vary globally by region and country. We are helping our clients face the daunting task of meeting these varied requirements by implementing enhanced data collection and processing techniques for all our clients to facilitate rapid and accurate production of ESI (electronically stored information) whether for litigation or compliance needs. This process includes identifying opportunities for clients to proactively create usable data repositories of company ESI or technology integrated business processes to meet regulatory requirements (like GDPR) to mitigate potential compliance failures. We can bring best of breed tools or work with client’s existing tool portfolio to create the robust eDiscovery business processes to ensure complete, accurate and timely production of required data.</p>	

8.1.48 Integreon

Jeff Davis	
jeff.davis@integreon.com +44 (0) 20 7855 6020	
100 Leman Street, London, E1 8EU	
www.integreon.com	
<p><u>Company Description</u></p> <p>Integreon is a trusted, global provider of award-winning legal, business and research solutions for leading law firms, corporations, financial institutions and professional services firms. Integreon applies a highly trained, experienced staff of 2,400 associates globally to a wide range of needs that require scale and expertise, enabling clients to become more operationally efficient by streamlining operations, maximising investment and improving the overall quality of their work. With delivery centres on four continents, Integreon offers multi-lingual, around-the-clock support, as well as, onshore, offshore and onsite delivery of services.</p> <p>Clients choose Integreon based on the depth of the company’s outsourcing experience and scale of its onshore and offshore service; its technical capabilities and its unrivalled subject matter expertise. These offerings can be supported either on-site at the client or from any of the company’s 14 ISO security-certified delivery centres around the world. Integreon’s existing clients also benefit from the company’s ability to work with them to evolve the original approach as requirements change over time and new best practices emerge. This level of partnership, trust and delivery of services that are mission critical and strategy dependent, has made for client relationships that span more than ten years.</p> <p>For our UK, US and global document review clients, Integreon’s ability to offer highly competitive commercial models without forgoing quality is based on 20-years refining and delivering process efficiencies for managed review and supervised review regardless of the delivery centre. Integreon also offers multi-lingual document reviews in more than 50 of the world’s languages. Integreon is platform agnostic and can readily work with any eDisclosure hosting provider or can recommend a best-fit preferred partner. Either way, clients experience seamless project management and integration of technology and resources.</p> <p>Over the last seven years, Integreon has also won more than 50 industry awards across a variety of disciplines, including ensuring the successful and timely review of more than 50 million documents across a multitude of litigation and compliance matter types.</p>	
<p><u>Vendor Offerings</u></p> <p>Document Review</p> <p>Whether clients need a comprehensive document review service or simply on-location staffing to augment existing processes, Integreon has the experience, flexibility and operational scale to meet most needs. The company follows rigorous, defensible processes to deliver predictable, consistent, high-quality privilege and responsiveness reviews onshore, offshore or on-site.</p> <p>For more than a 20-years, Integreon has run managed reviews on a wide range of matter types and complexities. From review centres in the UK, US, India and the Philippines, Integreon can meet client preferences for the right mix of onshore, offshore, and on-site service delivery, and can quickly scale resources for matters of all sizes. In all cases, Integreon will work with and support end-client or law firm teams to produce high quality, commercially competitive solutions to review tasks using experienced document reviewers.</p> <ul style="list-style-type: none"> • Managed Review: Globally managed review processes utilizing industry-standard best practices, documented defensible processes and in-depth performance metrics to offer increased client visibility into project status, costing and results. Managed review is available onshore, offshore, on- site and via blended service delivery and 	

innovative pricing models. Integreon has experience with first or subsequent stage reviews, redactions, objective or subjective coding in the context of litigation, investigations (regulatory and internal), arbitrations and Data Subject Access Requests.

- **Dedicated Review Teams:** Dedicated teams deliver high-value services with a greater level of consistency based on their subject matter expertise and familiarity with specific client preferences.
- **On-Site Reviewers:** Associates placed on-site at law firms to provide the advantage of contract reviewers that can be directly managed under the firm's own review processes.
- **Technology Consulting and Service:** Utilizing technology-assisted review, Integreon has the expertise, resources and key partnerships needed to manage your legal and compliance review requirements. Clients can choose document review by itself or combine the service with one of the leading review platforms for an integrated approach.

Data Reduction and ECA

In conjunction with its partners, Integreon's process integrates early case assessment (ECA) with data processing to help clients reduce data volumes and make informed decisions about whether to settle a case or proceed with litigation. Customizable reports help clients consider the risk, cost, and time required for a full discovery process.

Case Management

Using its Allegory system, Integreon can provide a platform to case-manage matters, from start to finish. Pleadings, Witness Statement, Court Transcripts, Experts Reports, key advice and correspondence can be drawn together with Court Orders and key documents, stored in one place and easily shared among the team and extended team, without the need for email. All documents can be cross-referenced and hyperlinked and the platform can be used to readily create digital bundles and chronologies, with the ability to re-order documents simply (without the need to re-number the documents). Work product, lawyer notes and key commentary can be shared instantly among teams and added to each document.

Data Breach Review and Examination Services

When a data breach occurs, clients need to respond quickly and with complete accuracy to ensure risk is mitigated and all obligations are met. Working with cyber security practices and leveraging its global resources, Integreon helps clients with the identification and extraction of sensitive PII and PHI data and prepares breach notifications to affected individuals, state attorney generals, consumer protection authorities, and/or national credit bureaus. Clients depend on Integreon's ability to rapidly respond in order to meet critical regulatory obligations and its quality-controlled data handling throughout every step of the process.

8.1.49 Intelligent Voice

Nigel Cannings	
nigel.cannings@intelligentvoice.com + 44 (0) 20 3627 2670	
St Clare House, 30-33 Minories, London EC3N 1BP	
www.intelligentvoice.com	
<p><u>Company Description</u></p> <p>Intelligent Voice Limited is a global leader in the development of proactive compliance and eDiscovery technology solutions for voice, video and other media. Intelligent Voice® turns audio, video, email and IM into smart data, using a powerful Machine Learning Engine, combined with the fastest commercially available Speech to Text processing. Featuring biometric speaker identification, custom language and acoustic modelling and both on premise and in-cloud integration, to provide you with the best processing and analytics tool available on the market.</p> <p>New for 2019, a Relativity One plugin to allow you to work securely with audio natively in the cloud.</p> <p>Intelligent Voice enable government agencies, banks, insurers, litigation support providers, and international consultancy and advisory businesses to manage risks and meet regulatory requirements. The company is headquartered in the United Kingdom and has been providing market leading solutions across structured and unstructured data since the infancy of Optical Character Recognition in the early 1990s.</p> <p>Fundamental to the success of the company, the patent-pending technologies Intelligent Voice® and SmartTranscript™ are developed by a team of dedicated researchers and system engineers based in the UK. Ownership of the core technology resides with Intelligent Voice. We continue to lead the market and will maintain our strengths in the areas of thought leadership, innovation, R&D and providing solutions to our clients.</p> <p>Intelligent Voice was recently granted a patent for its “Privacy Preserved Speech” product, which enables data to be encrypted at source, and searched using encrypted search terms.</p> <p>Key to the Intelligent Voice ethos is Privacy, Performance and Price. Intelligent Voice presents itself as a “cloudy” solution, but it can be deployed on-premise or in a private cloud. Intelligent Voice does not use public cloud services for its speech to text</p>	
<p><u>Vendor Offerings</u></p> <p>High speed audio and video analysis and review underpinned by:</p> <ul style="list-style-type: none"> • Ultra-fast speech to text processing using NVIDIA® GPU cards, whether server or cloud based • Topics of interest automatically surfaced via a proprietary approach • Lattice based searching – combining the best of transcribed text and a word probability lattice to offer the widest possible range of searches across a dataset, without the over-retrieval of phonetic search • Biometric voiceprint searching – independent of any metadata or transcribed text. 	

Results from telephone calls or audio or video files that can be ingested into any eDiscovery system as:

- Speaker-separated US federal court format transcript text file
- IV Note; an automatically generated email containing the speaker separated transcript text within the body of the email and/or the original audio or video file as an attachment
- Data load file (.DAT)
- Standalone JumpTo™ Review Player html file containing navigable transcript text and key topics combined with a player for the embedded audio / video file.

Audio historically sat in its own isolated silo, with phonetic search – searching on the sounds that make up the words rather than the words themselves – the only available tool. However Phonetic Search (sometimes referred to as Audio Search) in isolation has significant drawbacks:

- Phonetic / Audio Search does not give you “unknown unknowns” – you need to know what you need to know before you can find it.
- Phonetic / Audio Search does not produce text. The workflow for any matter involving more than just audio – emails, IMs, scanned documents, etc – relies on text-based review, as do analytics tools such as Relativity and Brainspace.

Intelligent Voice® for eDiscovery have been designed by a team that have undertaken audio review themselves, and as such the toolset is intuitive and easy to use. The unique, pat pending JumpTo™ Review Player cuts down review times significantly. Intelligent Voice® gives great power out of the box, enabling thousands of hours of audio to be processed each day. Intelligent Voice® only exposes what is relevant to an individual user or organisation.

One user said that it cuts down review time based on other tools they had used by 70%.

Native Relativity plugins for on-prem and Relativity One

- Transcribe audio and video to text direct from Relativity
- Perform text and lattice based searches using native Relativity searches
- Full JumpTo functions as part of a native viewer
- Search terms highlighted for immediate review
- Redaction available from Q2 2019

Secure Meeting room recording: **New for Q2 2019**

- Record and securely transcribe audio on any iPhone. No cloud transcription!
- Using multiple devices placed around the room, merge the best transcriptions automatically for the highest quality results
- Perform language model building direct on the phone to improve quality
- Edit transcripts within the app
- Email completed transcripts
- Multiple languages

Chapter 8 – Supplier & Software Details

- Store and search transcripts and audio files in the cloud using the “PPSP” patented secure search system: Encrypted on the phone and searched with encrypted search terms
- Ideal for meetings, recording calls and depositions, where the highest level of privacy is required

See the Intelligent Voice entry in the Software Section for more details.

8.1.50 Inventus

Adrian White,	
awhite@uk.inventus.com +44 (0) 20 3727 7129	
50 Finsbury Sq, London, EC2A 1HD	
www.uk.inventus.com www.inventus.com	

Company Description

Inventus is a global eDiscovery management practice focused on reducing the costs and risks associated with the discovery process through the effective use of leading technology. For over 25 years, Inventus has been at the forefront of discovery services and has worked with corporations, law firms and government agencies to develop a deep understanding of their needs. A truly global organization with headquarters in both Chicago and London, Inventus has offices throughout the United States, Europe and Asia where they have supported review in over 35 languages. Inventus is also a Relativity Best-in-Service Orange partner. Please contact Inventus at info@inventus.com or visit www.inventus.com for more information.

Vendor Offerings

- **Discovery Management:** Inventus’ technology and legal project management expertise provide clients with a cost-effective and defensible disclosure process. Our proprietary workflows and solutions, coupled with our unparalleled expertise and consultative approach, allow corporations, law firms and government agencies to recognize extensive disclosure-related efficiencies and, in turn, substantially mitigate their cost and risk throughout the process. Inventus’ proprietary discovery management platform is fully enabled within Relativity. **Luminosity** is an easy to use platform that seamlessly integrates with leading industry applications. It allows you to inform your case strategy early in the litigation life cycle as it allows you faster access to data. Luminosity reduces cost and risk by processing data once, culling data collection, and streamlining the review process.
- **Document Review:** Inventus provides customers with comprehensive review services, leveraging leading technology, Technology Assisted Review (TAR), Early Case Assessment (ECA) and a team of legal review experts, to save clients time and money. Our team has managed thousands of document reviews for Fortune 500 companies in a variety of sectors. As a global company, we also provide services wherever you need us and in over 36 languages.
- **Dashboard Analytics:** Spotlight is a business data analytics dashboard that provides full visibility into all of your key metrics including data spend, ROI and reviewer statistics. Users have immediate access to any structured data set, such as e-billing, data volume or matter detail. Spotlight provides you with fully customizable and intuitive dashboards to assist in managing department functions, giving you valuable information to improve the decision making process.

Key Features:

- Instantly see key metrics, volumes and benchmarks on your own data in real-time. In addition to your own data, you now have the ability to measure and quantify outside counsel efficiency.
 - Live access to all the key metrics in a document review gives Spotlight users the ability to take control over the costly review process. In addition, by mapping data visually, Spotlight can also help identify gaps in data sets based on chronology or help spot missing custodian data.
 - Data is presented in fully customizable charts and graphs, preparation of budgets, benchmarks and executive level presentations now takes only minutes.
- **Digital Forensics:** The Inventus Digital Forensics practice consults on findings that come from reactive litigation and investigation cases to help close gaps in ethics and compliance programs, internal controls, and audit procedures so that your legal organization can become more preventative in its purpose. Inventus also provides evidence collection and forensic analysis services which include reports on:
- Internet Browsing and Search History
 - External USB Device History
 - Cloud Storage Activity
 - Webmail Analysis
 - Recycle Bin and Deleted Items Analysis
 - FTP Log In Analysis
 - Jump List, Shell Bag, LNK File and MRU File Analysis
 - Chat Log Analysis
 - Media Analysis
 - Anti-Forensics Analysis

8.1.51 IT Group UK Ltd (Part of Blackrock Expert Services)

Damian Donovan – Associate Sales Director	
Damian.Donovan@itgroup-uk.com	
Head Office : Unit 5 Lockside Office Park, Lockside Road, Riversway, Preston, PR2 2YS	
www.itgroup-uk.com	
<p><u>Company Description</u></p> <p>IT Group was founded in 2004 and at the time its main focus was IT consultancy for IT disputes and expert witness work. The forensic examination of computer systems necessary for this work quickly led to the recovery and collection of data for litigation purposes and the development of our e-Disclosure service offering.</p> <p>Our unique combination of commercial litigation expertise in the TMT sector, complemented by digital forensic capabilities in IP theft, regulatory disputes and fraud cases, has enabled us to develop and refine processes that maximise the potential and the benefits of our e-Disclosure service.</p> <p>We can deliver court-ordered formal e-Disclosure or informal intelligence gathering from your electronic documents, and offer support in all matters relating to:</p> <ul style="list-style-type: none"> ● Document collection in employment disputes ● Corporate litigation ● IPR disputes (software litigation) ● Loss/theft of trade secrets or confidential information ● Password encrypted document unlocking ● Email sender and content provenance ● Mobile phone and tablet content ● Cloud based storage <p>Why IT Group?</p> <p>As expert witnesses with expertise in software and digital forensics, IT Group combines technical knowledge with an understanding of the litigation process.</p> <p>Our team of forensic specialists has in-depth knowledge of data structures and complex files types to complement our range of forensic analysis tools.</p> <p>We utilise the latest industry software, hardware and techniques to assist with e-Disclosure obligations at any stage of the litigation process, offering swift identification and forensically-reliable collection of data for review.</p>	
<p><u>Vendor Offerings</u></p> <p>IT Group's e-Disclosure and digital investigation solution, Intella Connect, is a powerful web-based platform that enables legal and regulatory professionals to intelligently search, filter and review large volumes of electronic data from a variety of sources.</p> <p>Whether you require court-ordered formal e-Disclosure or assistance with intelligence gathering for litigation purposes, the Intella Connect search and review suite provides a fast, easy to learn, flexible solution for the investigation of electronic data.</p>	

The powerful processing engine can handle millions of documents and a variety of file types and provides users with a thorough breakdown of the data. The simple, user-friendly interface and intuitive search functionality helps streamline data search exercises, allowing you to take full control of the review and find critical information quickly, whilst keeping intact all relationships between files, custodians, attachments and more.

Built-in visual analytics help establish relationships between search results and documents, enabling users to track evidence across different file types and quickly and accurately identify key data.

The wholly web-based platform allows multiple reviewers to work on the same case simultaneously and can be accessed from any device with an internet connection. Whether you require one reviewer or multiple teams across different global office locations, Intella Connect is scalable and flexible to meet your requirements.

KEY BENEFITS AT A GLANCE:

- Cost effective – costs are based simply on the use of our Intella platform, not on volume or complexity, keeping budgets proportionate for both case and client.
- Intella is fast and powerful, but straightforward to use. A very visual presentation makes it easy to uncover relationships and to track and review evidence across many different file types.
- Ease of use is crucial if you use e-Disclosure tools only as and when a suitable case arrives. Work can proceed via secure remote access, without waiting to fit in extensive training. Intella is straightforward to use and intuitive making it easy to pick up again when a new case arrives.
- Intella will handle many millions of documents, but is up and running quickly, with little or no time required on-site. It breaks down the various file types, custodians, encrypted files, duplicates, languages and more, 'straight out of the box', providing key early indicators of the case.
- Backed by years of forensic IT expertise, the interpretation, management and presentation of deleted material, duplicates and internet history is professionally handled by our team.

FULLY PROJECT MANAGED - FROM COLLECTION TO EXCHANGE

We offer a fully project managed e-Disclosure service from data collection to exchange with third parties and management and maintenance of the review platform and review process.

Our e-Disclosure exchange service is delivered in accordance with industry best practices and accompanied by a witness statement ensuring that those using our service maintain a defensible position. We can interface directly with legal advisors, clients or technical teams as required to ensure that everything is as efficient and convenient as possible.

SUPPORT AND GUIDANCE

We pride ourselves on providing practical support, assistance and advice: an outlook that is a hallmark of our attitude to our work. As well as being assigned a dedicated e-Disclosure Account Manager, IT Group has a team of qualified e-Disclosure Consultants who are available 24 hours a day to provide both proactive and reactive support during the lifetime of your project.

GOVERNANCE AND BUSINESS EXCELLENCE

IT Group is dedicated to maintaining the highest level of security and is accredited to the ISO 9001 Quality Management Standard and the ISO 27001 Information Security Standard. Given that our business focuses on digital forensics, data recovery and processing, these accreditations are at the heart of our ethos and commitment to the highest standards. To ensure the security of our clients data, the Intella Connect platform is protected by two-factor authentication and all harvested and exchanged documents are scanned using anti-malware software. All data is stored in our own data centre based in the UK.

FORENSIC DATA HARVESTING

Our e-Disclosure consultants are forensically trained and we have a number of additional services for the forensic extraction of content from workstations, laptops, servers, mobile devices and other storage media if required. We can often also retrieve and restore deleted material including emails, documents and evidence of computer usage even if it has been deliberately deleted, corrupted or damaged by viruses.

DOCUMENT OCR

As a result of the development of our forensic investigations division, we have a huge amount of computing 'horsepower' at our disposal. This means that tasks such as high volume indexing and the OCRing of vast amounts of documents is well within our capacity.

8.1.52 JND eDiscovery (US)

<p>Scott Lombard, Senior Vice President</p>	
<p>scott.lombard@jndla.com +1 612-328-9920</p>	
<p>JND eDiscovery 431 1st Avenue North Suite 410 Minneapolis, MN 55401</p>	
<p>http://www.jndla.com/ediscovery</p>	
<p><u>Company Description</u></p> <p>JND eDiscovery is an innovative legal services firm serving public and private sector clients in the areas of Data Collection, Processing, Review Hosting, Analytics, Managed Review and Production. Understanding that each case is unique, JND's industry experts work closely with clients to design custom workflows, tailored dashboards and real-time reporting techniques, enabling case teams to work smarter and faster at a fraction of the cost.</p> <p>JND eDiscovery is a Minneapolis-based subsidiary of JND Legal Administration, a legal management and administration company led by a team of industry veterans who are passionate about providing superior service to clients. Armed with decades of expertise and a powerful set of tools, JND has deep experience expertly navigating the intricacies of multiple intersecting service lines including class action settlements, corporate restructuring, eDiscovery, mass tort claims and government services. Headquartered in Seattle, JND Legal Administration is trusted by law firms, government agencies and Fortune 500 companies across the globe.</p>	
<p><u>Vendor Offerings</u></p> <p>JND currently manages the largest cloud production environment of RelativityOne on the market. By moving to the cloud, JND offers clients infinite scalability, the most cutting-edge features, and compliance with the industry's most stringent security protocols. JND's robust environment allows data to be transferred 10x faster than non-cloud based platforms. With unprecedented search speeds of <1 second per million documents, JND is geared to support the largest and most challenging matters with ease. With JND, clients have access to the industry's most cutting-edge features, before they're made available to non-cloud providers.</p> <p><u>JND's key differentiators include:</u></p> <p>BEST IN BREED TECHNOLOGY</p> <p>Legal technology evolves rapidly, and it's easy to get left behind. JND eDiscovery takes advantage of the latest advancements in software and workflow design to cut costs and reduce burden. With every challenge you face, rest assured that you'll have the best technology and staff support the industry has to offer.</p> <p>BOUTIQUE ATTENTIVENESS WITH LARGE-SCALE CAPACITY</p> <p>We offer clients the attentiveness of a small firm with the capacity and experience of a global litigation support company. A consultant will be assigned as a single point of contact who will manage each project and serve your needs throughout the life of the project. Consultants are experienced eDiscovery professionals certified in Relativity. With strong values and shared goals, a partnership with JND is a natural extension of your team.</p> <p>EXTENSION OF YOUR TEAM</p> <p>Our focus is on your objectives. Working with JND's experts at the beginning of your case allows you to address and resolve hidden variables up-front that otherwise add unnecessary</p>	

time and expense. JND's collaborative approach ensures proper onboarding of your project and the results you expect. We work closely with your team throughout the life of your case to provide thorough on- and off-site training on review platforms, proper code form design, and effective managed review.

DEFENSIBLE WORKFLOWS

From a project's inception to delivery, quality assurance is paramount at JND. Through carefully developed workflows, expert personnel and best-in-breed software, we have proven that accuracy and efficiency can work in harmony to meet deadlines without compromising quality, at a competitive price.

JND eDiscovery's Service Offering Includes:

LITIGATION READINESS

JND's experts consult with clients to establish defensible and efficient protocols prior to litigation, ensuring that they are prepared to meet their varying discovery goals and obligations within budget and without surprises. We collaborate with HR and IT teams to map network locations and job roles within the client's organization.

COLLECTION

JND has a proven track record collecting from a wide range of data sources, including email, cloud data, network shares, hard drives and structured databases. Our team of certified experts leverage a continually growing array of best-in-breed collection and imaging tools to defensibly meet the varying needs of each collection. We offer both onsite and remote collection capabilities, and will consult with your team to determine the best technology to leverage on a per-collection basis.

ESI PROCESSING

JND delivers high-speed, predictable processing results through Relativity. We've combined best-in-breed technology with industry experts to develop a defensible, streamlined approach that delivers accurate results the first time. Key processing highlights include:

- Up to 2TB/day Throughput
- Keyword or Analytics-Based Culling
- Email Threading
- Near and Exact De-Duplication
- Hidden Data Detection
- Interactive Reporting
- NIST Filtration
- Automatic OCR of Images

JND's processing environment is capable of handling single processing sets up to 5TB without decreasing system performance. Because we use Relativity Processing, documents are instantly reviewable when processing completes, eliminating the cost and time incurred by exporting and loading between platforms.

REVIEW HOSTING

JND delivers an industry-leading review platform, RelativityOne, providing a feature-rich backbone to organize, track and quality control your review. With an array of dedicated high-speed servers, JND's Relativity environment was designed to outperform competition in system uptime and speed for cases small and large. The environment features:

- Able to Support 100+ Million Document Workspaces
- Military-Grade Encryption and Security
- Elastic Cloud Infrastructure
- Custom Reporting
- Proprietary Analytics

ANALYTICS

JND seamlessly integrates cutting-edge analytics capabilities into its processing and review workflow, allowing clients to defensibly leverage the benefits of analytics without requiring deep expertise into the "black box." JND offers a variety of analytic solutions proven to remove non-responsive data from the review set, promote responsive data, and generally expedite linear review. Such technologies include predictive coding, concept searching, clustering, assisted keyword generation, email threading and near de-duplication. Our analytics experts apply each of these technologies with a focus on defensibility and transparency.

PRODUCTION

JND offers a comprehensive suite of production capabilities to easily facilitate the creation, tracking, reporting and delivery of document productions in a variety of formats. All documents that have been produced are stored alongside their source record and can be referred to with a single click in the document viewer. For the life of the case, each production set will be available for export or future reference.

Military Grade Security

- FEDRAMP/FISMA Compliance
- ISO 27001
- SSAE 16
- SOC I, II and III
- AES 256-bit encryption for data both in transit and at rest

PROPRIETARY SOFTWARE (LayerCake)

Beyond our commercial-of-the-shelf software offering, JND's clients have access to JND's proprietary analytics software, LayerCake. LayerCake unlocks Relativity's full potential to mine your data using Analytics. By synchronizing results across TAR, clustering concept searching and other queries, LayerCake is able to calculate a single priority ranking for each document according to many criteria as opposed to just one. LayerCake's priority ranking can then be used to identify hidden pockets of data, promote key documents for urgent review and suppress junk from the document set.

SOFTWARE

JND offers clients access to the following COTS and proprietary software:

- **Collection**
 - FTK
 - EnCase
 - Cellebrite
 - Logicube
 - F-Response
 - Stealth Forensic

- ***Processing and Early Case / Data Assessment***
 - o RelativityOne
- ***Review and Analytics Tools***
 - o RelativityOne
 - o JND LayerCake™ (patent-pending)
- ***“All in One Products” (Both ECA and Review)***
 - o RelativityOne

8.1.53 KNOVOS (Capital Novus)

Sid Jiwnani	
SJiwnani@uk.knovos.com +44 (0) 20 3514 0075,	
Evergreen House, Grafton Place, London NW1 2DX	
http://www.knovos.com	
<p><u>Company Description</u></p> <p>Founded in 2002, Knovos (formerly Capital Novus) is a leading legal technology firm headquartered in Fairfax, VA, just outside of Washington, DC, with an exclusive focus on e-Discovery and information governance technology. As an industry pioneer, Knovos has developed innovative technical solutions for law firms, corporations and government agencies, meeting our customers' needs for better, faster and more cost-efficient e-Discovery and information management solutions. Our suite of solutions is world class, and backed by an unparalleled engineering, development and training support team that delivers reliable and effective end results.</p> <p>These solutions include, but are not limited to: e-Discovery, Information Governance & Risk management, Compliance monitoring, Virtual secure data room, Trial Consulting, Content Intelligence & Analytics, and Performance Budgeting/Reporting Solutions. The ground-breaking in-house product line and computing platform is designed for dependability, robustness, speed, and flexibility. It provides an unparalleled competitive advantage for our clients.</p> <p>Today, Knovos is one of the fastest growing, full-spectrum, global e-Discovery and information analytics leaders. The company is committed to enhancing customer satisfaction by consistently providing e-Discovery, enterprise content and information technology and knowledge management solutions that reflect quality, reliability, speed, versatility, data security and adaptability.</p> <p>The company has 300+ staff spread across its international offices - http://www.knovos.com/about-us-knovos/offices</p> <p>Knovos is committed to being the best provider of Litigation and Information Technology Services in the world.</p>	
<p><u>Vendor Offerings</u></p> <p>eZSuite™ is a complete litigation lifecycle solution from data processing to presentation (see below).</p> <p>eZManage™ is a project management software to track all matter progress from initiation to invoice.</p> <p>nayaEdge™ is a highly secure content management system which processes the data as you save it.</p> <p>Cryptacomm™ is a virtual data room and doc sharing platform especially useful in due diligence.</p> <p>Knovos eZSuite solution and portfolio of technological services addresses all phases of the e-Discovery lifecycle. The company manages all aspects of data collection, ingestion, processing, early case assessment, hosting, review, analysis, presentation and production services. By addressing current electronic discovery requirements and maintaining the flexibility to address future needs, Knovos solutions perform all of the back-end tasks so that attorneys are free to focus on the substantive aspects of their case.</p>	

8.1.54 KPMG LLP

<p>Darren Pauling (Managing Director) Mark Cordy (Director)</p>	
<p>Darren.Pauling@kpmg.co.uk +44 20 7694 5565 Mark.Cordy@kpmg.co.uk +44 20 7311 2376</p>	
<p>15 Canada Square, London, E14 5GL</p>	
<p>https://home.kpmg.com/uk/en/home/services/advisory/risk-consulting/forensic-landing/forensic-technology-services.html</p>	
<p><u>Company Description</u></p> <p>KPMG help corporate and financial clients, and their in-house and external legal counsel to rapidly respond to data needs in disputes, investigations, and regulatory and internal reviews.</p> <p>We have a highly-experienced team which includes a range of specialists, industry sector experts with in-depth knowledge of e-disclosure, incident response, investigations, regulatory inquiries and data enhancement and remediation. We have over 500 forensic technology specialists globally and have been offering leading forensic services for many years.</p> <p>We use industry leading technology, supplemented with our in-house customised solutions, to address your specific needs. Our flexible charging options mean we can help clients control costs at every stage of the process.</p>	
<p><u>Vendor Offerings</u></p> <p>Forensic Investigation and Expert Witness Services</p> <ul style="list-style-type: none"> • We bring together data collection, evidence handling, processing, analysis, reporting and testimony to corporate, legal and government organisations. We can investigate breaches of information security policy, IT asset misuse or hacking activities and are experienced at capturing and analysing data from a wide range of electronic devices, media and sources including desktop and laptop computers, servers, backup tapes, mobile devices and telephony systems. • The team attend court to provide testimony regularly in support of wider investigations including acting as Expert Witness. In addition to oral testimony we provide expert reports and witness statements for court in civil litigation and criminal matters. <p>eDiscovery – Regulatory and Litigation Management</p> <p>The burden of regulation, litigation and investigations is huge and it shows no sign of getting any smaller, we can assist you by providing:</p> <ul style="list-style-type: none"> • A full end-to-end eDiscovery technology platform, including collection, processing and hosting of all data types, including email, edoc, chat, social media, audio, risk and trade data. • Established eDiscovery workflows and optimised processes. • Standardised and consistent dashboards and reporting, configured to suit the relevant stakeholders. • Access to new technology and workflows (TAR, machine learning, Brainspace) through KPMG strategic relationships. 	

Data Separation and Remediation

- The data remediation service enables companies to identify, map and remediate large volumes of key unstructured data (Email, Word, PDF etc.) and structured data (database driven applications such as SAP, Salesforce etc.) throughout their infrastructure.
- The service is deployed in an auditable and risk-adverse manner, whilst ensuring minimal impact on business activities.
- Remediation can take many forms depending on the companies' requirements, including removal, transfer, duplication and / or forensic deletion of data.
- Demand stems from regulatory requirements, legal mandate, M&A / Divestment activity or fit for sale preparation.

KPMG International's Trademarks are the sole property of KPMG International and their use here does not imply auditing by or endorsement of KPMG International or any of its member firms.

8.1.55 KLDiscovery UK

James Morrey-Jones, Head of Legal Technologies,
EMEA

Nexus, 25 Farringdon Street
London EC4A 4AB
+44 (0) 20 7549 3862 Office
+44 (0) 77 7541 0708 Mobile
james.morrey-jones@kldiscovery.com



COMPANY DESCRIPTION

KLDiscovery, formed from the merger of Kroll Ontrack Legal Technologies and LDiscovery, provides technology-enabled services and software to help law firms, corporations, government agencies and individuals solve data challenges of every size and complexity. We can help with everything from the investigation of a single device or mailbox to a multi-terabyte, multi-jurisdiction legal review involving hundreds of data custodians and utilising the latest in Artificial Intelligence technology. The company is a global leader in delivering best-in-class eDiscovery, information governance and data recovery solutions to support the litigation, regulatory compliance, internal investigation and data recovery and management needs of our clients. Serving clients for over 30 years, KLDiscovery offers data collection and forensic investigation, early case assessment, electronic discovery and data processing, application software and data hosting for web-based document reviews, and managed document review services.



Our history and experience as one of the very first companies involved in digital evidence and data recovery means that we understand better than anyone the challenges faced when managing electronic evidence. We attribute our success to our unique culture, our client-focused services, our expert consultant and technical teams, and our industry-leading document review platforms and infrastructure. This ensures that risk is minimised and we deliver a service that is second to none, whatever our client's size or requirements. We are an Orange-level Relativity Best in Service Partner, a Relativity Premium Hosting Partner, and we maintain ISO/IEC 27001 certified data centres with state-of-the-art technology and security.

KLDiscovery operates in over 40 locations in 19 countries around the world and continues to expand rapidly. With more than 1,100 employees in multi-disciplinary teams dedicated to assisting clients, we can deploy consultants familiar with local laws, languages and cultural issues, offering a truly global service. We pride ourselves on being “around the globe and across the street”, ensuring that our worldwide technological expertise is tailored locally to clients whatever their size and requirement. Our European head office is located in London where we have over 100 staff and carry out in the region of 500 assignments per annum. We have dedicated data centres in the UK, Ireland, the US, Canada, Germany, France and Japan, providing the capability to operate in situations where there are legal difficulties with international data transfer. Our capabilities are enhanced by our mobile Remote Collection Manager® and NPC data collection and review solutions. These enable forensic collections, e-disclosure exercises and investigations to take place anywhere in the world irrespective of local infrastructure.

VENDOR OFFERINGS

Edisclosure: We offer Nebula™, a proprietary end-to-end cloud-optimised eDiscovery solution, as well as Relativity processing and review capabilities and our EDR review platform. All of our platforms include developments unique and proprietary to KLDDiscovery such as our nearline hosting capabilities, and our industry-leading Predictive Coding and Automated Workflow technology. Nebula and Relativity also include additional enhancements such as A/V Suite, AutoRedaction and Native Excel Redaction. EDR includes visual communication analysis, phonetic audio searching and in-platform machine translation.

Managed Review Services: KLDDiscovery's Managed Review team has offered review services in the EMEA area since November 2014 (US services began in 2008). Our dedicated review centre in London holds seats for 100 reviewers, with an additional 45-seat document review centre in Böblingen, Germany, and a 100-seat review centre in Katowice, Poland offering responsive, multilingual review from qualified lawyers at exceptionally cost-effective rates. All of our document review centres are owned and managed by KLDDiscovery, with review managers employed by KLDDiscovery, ensuring that we have complete control of the staffing and security of the review process.

Our robust productivity reporting enables in-project efficiency and our Six Sigma-based quality control policies and procedures ensure a high level of review accuracy. We ensure that the highest calibre of review lawyers assist with your cases, working closely with you to deliver the precision in document categorisation that you would expect from lawyers at your own firm.

Strategic Consulting & Case Assessment: Members of our case management team have extensive experience in the ediscovery industry and we employ a team of consultants and client services professionals with extensive and diverse backgrounds in law, technology, project management, business and other areas. Our services range from case management tasks and assistance with preparing search term reports to full consulting services focused on search term development, iterative analysis, early case assessment and sampling to assist you in areas including the negotiation of terms, culling of irrelevant data and identification of relevant material or specific documents. Our consultants utilise their legal, technical and ediscovery backgrounds together with their depth of knowledge of review platform search tools and capabilities to provide exceptional support to clients in setting up document processing and review.

Computer Forensics: KLDDiscovery is a leading computer forensics provider and offers expert analysis and triage of evidence held on all forms of electronic media. Our team includes EnCase, AccessData, X-Ways and Nuix-accredited practitioners with over 20 years' experience in the field. We utilise all of the industry-standard forensic platforms as well as having the capability to produce bespoke forensic solutions. Both remote and global on-site assistance are possible depending on technical requirements. In particular we offer our proprietary Remote Collection Manager forensic tool which enables non-technical personnel to carry out secure, fully audited and defensible forensic collections via USB using a pre-configured external hard drive.

Our computer forensics team works closely with other areas of the business including our eDiscovery consultancy to offer the most efficient and cost-effective means of recovering and analysing digital evidence, following strict chain of custody and forensic protocols. Our investigators have appeared as expert witnesses on countless matters at courts and tribunals at every level of the justice system.

Nebula™

Relativity®



8.1.57 LDM Global

Sean Cordes	
scordes@ldmglobal.com +44 (0) 7911 748149	
11 Old Queen St., London, SW1H 9JA	
www.ldmglobal.com	
<p><u>Company Description</u></p> <p>Founded in London in 1996, LDM Global is an information management, data solutions and litigation support firm. The company specialises in providing eDisclosure, Digital Forensics, Offshore Document Review and Cybersecurity services.</p> <p>Having completed work in more than 40 countries, LDM Global is committed to adding value to its clients, helping professionals reduce risk and find critical evidence. Clients are supported 24 hours a day, seven days a week from four secure global data centres, in the United Kingdom, the United States, Australia and the Caribbean; operations hubs in Texas and India; and certified consultants in key international locations.</p> <p>Four uniques set us apart:</p> <ul style="list-style-type: none"> • Global Partner: We've worked in 43 countries, have data centres in four: the U.K., U.S., Australia and the Cayman Islands, and have a global network of trusted partners. • Not a Vendor. A Partner: Our expert eDisclosure and digital forensics consultants allow you to do more with less and compete with firms twice your size. Gain a competitive advantage by adding us to your team for litigation support without the investment of a costly in-house team. • Proportionate and Predictable Costs: LDM Global offers solutions to suit a broader range of matters, including smaller matters with fixed fees. A free, 1-hour project scoping call with a consultant helps you understand costs for realistic budgeting. • Insolvency & Offshore Specialisation: Our insolvency experts help to unravel the mysteries of insolvent entities by leveraging technology to build chronologies of events, perform tracing exercises and uncover whether there was fraud through investigations using bank statements to follow the money, etc. 	
<p><u>Vendor Offerings</u></p> <p>LDM Global's expert legal and technology resources focus on consultancy for law firms and corporations and include:</p> <p>Services offered:</p> <p>eDisclosure</p> <ul style="list-style-type: none"> • Identification and Preservation of ESI • Data Subject Access Request support • Data Processing • Data Analytics & Consulting • Technology Assisted Review • Hosted Document Review • Managed Document Review 	

- Proactive Project Management
- Managed Services
- Production Services

Digital Forensics

- Identification and Preservation of ESI
- Defensible Collections
- Data Scoping and Analysis
- Custodian Interviews
- Expert Testimony
- Strategy and Consulting

Cybersecurity

- Vulnerability Assessments
- Gap Analysis
- Remediation
- Employee Training
- Security Operations Center (SOC) as a Service
- Compliance Support

LDM Global offers full support on Relativity, a powerhouse tool offering advanced analytics, assisted review, hosted document review and production. In addition, another option that some clients find of great value is to have LDM Global host the Relativity software – saving on infrastructure costs -- while opening up permissions to allow the client to get more hands-on and do much of the eDisclosure work themselves.

While being first to market in the U.K. with Relativity, we also offer Viewpoint, a technology platform providing an all-in-one-tool, giving our clients options for the tool that best fits their needs. Viewpoint includes processing, advanced analytics, assisted review, hosted document review and production all in one platform. In addition to creating efficiencies through keeping your data in one tool, Viewpoint also allows for the flexibility to offer clients predictable and fixed fee pricing. This enables the use of large case technology to be deployed on small matters and is a cost benefit to clients.

8.1.58 Legastat

Paul Fox – Sales Director	
paul.fox@legastat.co.uk 07887 408521 020 7492 6510	
57 Carey Street, London, WC2A 2JB	
www.legastat.co.uk	
<p><u>Company Description</u></p> <p>Established in 1953 Legastat have been providing litigation support services throughout the UK for over 60 years. Today, Legastat combines a range of traditional legal reprographics services with innovative technologies for eDisclosure, maintaining our focus on high quality and excellent customer care.</p> <p>Located in the heart of legal London we've been trusted to deliver an independent, professional and efficient service to top law firms, corporations, government agencies, small law firms and sole practitioners; all of whom rely on us to meet their litigation support and disclosure obligations on time, accurately and efficiently.</p> <p>At Legastat we put our customers' needs, quality and confidentiality at the heart of everything we do. This is demonstrated by our ISO 9001 accreditation for quality management, our ISO 27001:2013 accreditation for information security management and our Cyber Essentials Accreditation. Our extensive work with UK Government over the last 10 years and Legastat successfully retendering as a supplier for the latest Crown Commercial Services eDisclosure Framework, RM3717 in 2017 are further testament to the high standards we maintain throughout our business.</p> <p>In 2014 Legastat enhanced our reputation as a leading provider of eDisclosure and litigation support services to the Public Sector, by launching our IL3 accredited review and processing services. Already in use by a range of Government organisations, our solution robustly addresses our customers concerns of information security when using remote access review systems. This platform continues to provide our Government clients with remote access eDisclosure services with enhanced levels of security and information assurance.</p> <p>As the only original litigation support provider in London still operating today, Legastat is a business with a rich history and a vibrant personality. We are proud of our heritage and the core principles of quality, integrity and innovation that make us what we are today.</p>	
<p><u>Vendor Offerings</u></p> <p>Along with our full reprographics offerings, Legastat offer a range of software and service solutions to assist our Clients with their eDisclosure needs. Our service offering covers both hardcopy and softcopy solutions, underpinned by expert project management and technical assistance.</p> <p>In 2016 Legastat became the UK's first Recommind/OpenText Axcelerate 5 Cloud partner in the UK eDisclosure market greatly enhancing our capability and review capabilities, incorporating class leading predictive coding and intelligent data analytics to our all-round service.</p> <p>In 2014 Legastat added a highly secure and fully accredited to IL3 solution to our toolkit, enabling us to handle protectively marked material up to RESTRICTED/OFFICAL SENSITIVE for both processing and review. If you work with the Public Sector, please speak to us about how we can assist you.</p> <p>Our full range of services provides everything from forensic collection of data, filtering, analysis, review and production of documents. To enable us to do this we use some of the world's leading software and hardware solutions, including</p>	

Chapter 8 – Supplier & Software Details

Axcelerate 5, Nuix, CaseLogistix, cicayda, Case Notebook, Concordance, Equivio, LAW, KOFAX and IPRO.

8.1.59 Lighthouse

Mike Brown - Director of Business Development	
mbrown@lighthouseglobal.com +44 (0) 203 196 1273	
1 King William Street, London, EC4N 7AF	
https://www.lighthouseglobal.com	
<p><u>Company Description</u></p>	
<p>Lighthouse provides software and services to manage the increasingly complex landscape of enterprise data for compliance and legal teams. Lighthouse leads by developing proprietary technology that integrates with industry-leading third-party software, automating workflows, and creating an easy-to-use, end-to-end platform. Lighthouse also delivers unique proprietary applications and advisory services that are highly valuable for large, complex matters, and a new SaaS platform designed for in-house teams. Whether reacting to incidents like litigation or governmental investigations, or designing programs to proactively minimize the potential for future incidents, Lighthouse partners with multinational industry leaders, top global law firms, and the world’s leading software provider as a channel partner.</p>	
<p><u>Vendor Offerings</u></p>	
<p>Lighthouse provides software and services to manage the increasingly complex landscape of enterprise data for compliance and legal teams, whether they’re reacting to incidents like litigation, government, or internal investigations, or designing programs to proactively uncover the potential for future incidents. Through our best-in-class expertise, Lighthouse stands apart as a leader in industry best practices and workflows. Our proactive, high-touch approach has enabled us to build enduring partnerships with the most respected corporations and law firms around the globe.</p>	
<p>Smart Innovation</p>	
<p>At Lighthouse, we have built a culture of innovation – it’s at the heart of everything we do. We simplify complex problems using a combination of proprietary innovations and best-in-class, third party technologies, leading to new and better solutions for our clients.</p>	
<p>Enduring Partnerships</p>	
<p>Our clients have been relying on us as technology and service partners for more than 20 years. In addition to innovative technologies, we deliver extraordinary transparency, control, and flexibility to our clients, together with a proactive and high touch service, seeking to delight our clients, develop durable and efficient information governance and eDiscovery programs, and form long-lasting partnerships.</p>	
<p>Best-in-Class Expertise</p>	
<p>Our team has collectively worked on thousands of matters with clients including the world’s largest technology, pharmaceutical, financial services, and retail firms. Lighthouse has long-term partnerships with these multinational companies because we provide expert advice at the forefront of best practices and workflows. We continuously train and develop our teams, broaden our experiences, and deepen our knowledge to offer an elevated level of guidance.</p>	

8.1.60 LINEAL

Basir Tutakhil	
info@linealservices.com +44 (0) 20 7940 4799	
125 Finsbury Pavement, London EC2A 1NQ	
www.linealservices.com	
<p><u>Company Description</u></p> <p>Lineal provide bespoke solutions to complex client problems, giving them full confidence in the process and the delivered outcome. We operate at the cutting edge of digital forensics, cyber security and eDiscovery technology, using our expertise to exceed client expectations and operate within budget and tight timeframes.</p> <p>Since its beginnings in 2009, Lineal has grown into an experienced and reliable solutions provider in digital forensics, cyber security and eDiscovery and has created a team with over 50 years' experience in these areas. But regardless of rapid growth and success, the core values of strict ethics, quality service, and bespoke solutions for individual clients continue to prevail and are embedded into the culture of every team.</p> <p>From the outset, we partner with you to identify the resources and budgets needed to deliver the results you want. Our bespoke budget management and quotation tools allow you to predict pricing and resources, minimising inefficiencies and reducing your costs. We take the time to understand your digital forensic, cyber security and/or eDiscovery requirements, quickly identifying weaknesses and developing a clear strategy to deliver predetermined objectives.</p> <p>Our team maintains high security that stands up to the explicit management controls required by our ISO27001:2017 certified data security accreditation. Your data is backed up to the minute in secure environments which are on par with government agencies and major financial institutions.</p> <p>Based in the City of London, we are ideally positioned to provide an immediate and flexible response to your needs both in the UK and internationally.</p>	
<p><u>Vendor Offerings</u></p> <p>Lineal supports clients in meeting their digital forensics, cyber security and eDiscovery needs by providing bespoke solutions to complex problems.</p> <p>Our services include:</p> <p>Digital Forensics & Investigations</p> <p>Digital forensics has been a core offering since Lineal began. We are industry leaders in recovering digital evidence in a forensically defensible manner. Our teams are available 24/7 for domestic and international incident response. We continually invest in technical infrastructure and forensic software giving our clients the confidence their project is being managed with the latest equipment and technology.</p> <p><u>Services Offered:</u></p> <ul style="list-style-type: none"> • Data Collection • Data Recovery • Misuse and Fraud Investigations • Intellectual Property and Data Theft Analysis • Cell Site Analysis 	

Lineal Cyber Security

Cyber resilience is the best defence against today's new normal of constant cyber security risk. With almost every aspect of business now digitised, and most employees using mobile technology, cyber security is no longer simply an IT department matter; all stakeholders, from the 'shop floor' to the Board need to be actively engaged in managing cyber security risks. By working on a cyber resilience model, we help organisations identify weaknesses in their systems, create a plan to minimise business disruption in the event of an incident, and stay one step ahead of potential cyber threats.

Services Offered:

- Cyber Security Audit
- Vulnerability Assessment Scan
- Penetration Testing
- Cyber Incident Response
- Digital Forensics

eDiscovery

Lineal offers a complete eDiscovery service, providing clients with a clear idea of the scope of the data relating to a particular matter, and the costs of collection and review. We understand the challenges legal case teams and in-house counsel face when undertaking eDiscovery. Our team is qualified to the highest standard, and we are experts at quickly identifying the technologies and processes required to deal with a particular eDiscovery project. We provide creative solutions to eDiscovery challenges, working within the EDRM framework, and ensuring all identified data is collected, reviewed, and produced in a legally defensible manner.

Services Offered:

Information governance

Document Review

eDisclosure Services

- Early Case Assessment
- Technology-Assisted Review (TAR) /Predictive Coding
- Online Review through advanced eDiscovery platforms
- Data Analytics
- Data Hosting
- Data Processing

Managed Services

- Infrastructure as a Service
- Managed Seats - A flexible 'pay-as-you-go' option which allows you to get the benefit of tools such as Relativity as and when you need them.
- Outsourced Litigation Support Professionals - Access to our staff including our eDiscovery Counsel team, Forensics team, and Document Review Facilities, when you need them, in whatever jurisdiction.

Managed Document Review

Our guiding principle in document review is to minimise costs and risk by getting it right the first time. This applies to a broad spectrum of reviews, including:

- Meeting disclosure obligations in commercial litigation, both domestic and cross-border;
- Responding to disclosure requests in regulatory investigations – e.g. banking, white collar crime, antitrust;
- Data Subject Access Requests (DSAR) under the General Data Protection Regulations (GDPR), as well as other statutory requests;
- Compliance matters and internal investigations.

Legal Document Services

Our legal document services production department produces a full range of supporting information for our clients' legal matters. We provide a 24/7 service in order to deliver full and timely support for the most aggressive deadlines.

Services Offered:

Litigation Bundles / Transaction Bibles

We offer a wide range of services from digital printing, copying and scanning from A5-A0 in colour and monochrome.

- Creation of hardcopy and Electronic Bibles
- Creation of hardcopy and Electronic Bundles
- Optical Character Recognition (OCR)
- Electronic Pagination / Bates Labelling

Document Coding

- Logical Unitisation
Determining document boundaries and capturing family relationships.
- Objective Coding
Manually reading documents and capturing bibliographic information.

8.1.61 LitSavant Ltd

Mark Dingle (Managing Director)	
mark.dingle@litsavant.com +44 (0)20 8923 4333	
70 Leyton Park Rd London E10 5RL	
www.litsavant.com	
<p><u>Company Description</u></p>	
<p>LitSavant Ltd was established by Mark Dingle in January 2010 as a UK technology firm specialising in eDiscovery and litigation support services. Originally founded to assist with the practical application of technology to eDiscovery and litigation support, we specialised in the use of Relativity™ the leading litigation support platform.</p> <p>As part of our consulting practice we realised that the Relativity platform was missing a simple method of building logical rules to check coding as it happened, rather than searching for inconsistent coding results after the event.</p> <p>In response to this need, we developed the LitSavant Conformity Engine – a simple Relativity application which performs checks on data entry as it happens, to ensure that the information entered is consistent with logical rules.</p> <p>We now focus exclusively on the distribution and support of this application.</p>	
<p><u>Vendor Offerings</u></p>	
<p>LitSavant Conformity Engine</p> <p>This is a Relativity application which enables users without programming knowledge to implement logical rules to ensure coding consistency in Relativity.</p> <p>The main uses of the application are:</p> <ul style="list-style-type: none"> • To prevent users entering coding that is internally inconsistent (e.g. Hot and Not Relevant) • To automatically send emails to inform key team members about amendments to questions and other custom objects or alert one set of people about the coding done by another (e.g. somebody has just tagged a Hot document) • To log errors in the coding process • To maintain a log of who coded what and when that is searchable from within Relativity • To prevent users from updating key fields after formal production <p>All of these functions operate not only on documents but also on any other custom object (e.g. Custodians), and can be applied at different stages within the Relativity eDiscovery process. The LitSavant Conformity Engine offers wider functionality than Relativity’s own custom event handler tool and can help users to effectively create or augment applications within Relativity, without developer involvement.</p>	

8.1.62 London Legal Discovery

<p>Graham Jackson, Senior eDiscovery Consultant</p>	
<p>graham.jackson@london-legal.co.uk</p>	
<p>Birchin Court, 20 Birchin Lane, London EC3V 9DU</p>	
<p>www.london-legal.co.uk</p>	
<p><u>Company Description</u></p> <p>London Legal provide full service eDiscovery and litigation support services to law firms and corporate organisations. Working in partnership with our clients, skilled technical teams bring years of experience to support all forms of legal documentation handling and the Electronic Discovery process.</p>	
<p><u>Vendor Offerings</u></p> <p>Headquartered in the City of London and a full-service operations centre in Dubai, UAE, our services include:</p> <p>Digital Forensics - Encompassing the identification, analysis and presentation of potential evidence found on digital devices. London Legal has global access to Computer Forensic experts to provide technology, process capability and professional support to help with the retrieval, analysis and management of Electronically Stored Information (ESI).</p> <p>Data Processing – The technical process providing the ability to store, view and search across multiple native file formats within one review platform. London Legal use the Relativity Processing engine to separate native files, extract metadata and OCR image files to catalogue and allow search functionality within the review process.</p> <p>Unitisation & Coding - Is the process of determining boundaries (the first and last page) of a document and identifying information fields within a document (author, subject etc.). Physical Unitisation is the use of paperclips or staples creating a physical relationship to identify which documents belong together. Logical unitisation involves human interaction to determine pages that belong in one document and indexing them by fields such as page number, document type, legal description and recording date.</p> <p>Early Case Assessment - Uses advanced search capability, data visualisation and combines Relativity Analytics to allow users to gain an understanding of their data and make informed decisions on what they need to review. London Legal ECA tools help cull irrelevant data and enables the exploration of data to assess the overarching facts of the case.</p> <p>Relativity Data Hosting - Is a document review platform acting as a single document repository allowing an unlimited number of users to review, analyse and search electronic and scanned hard copy documents in legal matters and investigations. London Legal provide an experienced technical project management team to support the document review process and advise best practice on project workflows.</p> <p>Relativity Data Analytics - Uses Structured Analytics and Conceptual Analytics to organise and categorize documents to make the review process more efficient minimizing the time your review team would otherwise spend coding irrelevant documents.</p>	

Machine translation - Is an integrated translation application within our Relativity environment. This allows our clients to translate sets of documents or documents 'on-the-fly' from over 70+ languages.

Managed Services - Is London Legal's solution to provide Relativity administrative control and cost certainty to enterprise clients in today's challenging eDiscovery industry. Our clients experience the full benefits of bringing Relativity 'in-house' without the added burden of maintaining a complex IT infrastructure and support network.

Managed Document Review - Situated in the City of London, our review centre houses experienced solicitors and paralegals for any case size. London Legal Project Management team oversee and provide document review guidance reducing the time-consuming and costly process of reviewing document intense projects allowing our clients to focus on the core issues of the case.

Legal Document Services – London Legal utilise the latest technology available in digital copying, printing and finishing equipment, ensuring high quality results and quick completion schedules.

Scanning - Our dedicated team work with high-end equipment and software capable of scanning any condition or size of documents and produce them into multiple formats to suit client review needs.

8.1.63 Maas Consulting Group

Jonathan Maas	
Jonathan@MaasConsultingGroup.com +44 (0)7957 140130	
19 Park Road, Burgess Hill, West Sussex, UK, RH15 8EU	
www.maasconsultinggroup.com	
<p><u>Company Description</u></p>	
<p>The Maas Consulting Group was formed in 2016 and is led by Jonathan Maas. Over the past 35 years he has developed significant expertise in:</p> <ul style="list-style-type: none"> • Managing electronic and hard copy data in a legal context, whether in the course of litigation during discovery/disclosure, regulatory or internal investigations, due diligence or any other situation where records need to be identified, collected, managed, assimilated and produced; and • Selecting, implementing and deploying technology to help lawyers work even more smartly in the modern world. <p>We specialise in working with lawyers, IT people and suppliers, negotiating, delivering cost-effective solutions, writing, speaking, listening, hearing, attention to detail, humour, determination, tact and diplomacy, change management, encouraging the best out of people, removing problems, team work, business integration and getting things done.</p>	
<p><u>Vendor Offerings</u></p>	
<p>The Maas Consulting Group's expertise translates into any number of propositions for different organisations. Examples include (but are not limited to):-</p> <ul style="list-style-type: none"> • Full coverage of all aspects of the Electronic Discovery Reference Model (EDRM) • Change management • Service provider selection and/or management • Establishing internal discovery teams • Streamlining existing discovery workflows • Identifying savings in external litigation spend • Litigation/discovery project management • Electronic Documents Questionnaire (Form N264) guidance • Business integration • Precedent H guidance • TeCSA/SCL/TECBAR eDisclosure Protocol guidance • Early data assessment • Civil Procedure Rules awareness training • Case Management Conference preparation • eDiscovery/eDisclosure strategy/response • Document reviews • User and requirements specifications for new software development • Project management of new software implementation 	

- Software assessment (time recording systems, know-how systems, DMS, etc.)
- Trial preparation
- Impact of the EU's General Data Protection Regulation (GDPR)
- Insights into UK and European markets
- Project management
- Introduction to relevant legal procedure and the drivers behind litigation
- Assistance with presentations to legal audiences
- Leading market-facing roundtables
- Drafting joint white papers and/or webinars
- Guidance developing user interfaces and/or user manuals
- Functionality roadmaps
- Market awareness
- Internal corporate presentations on the state of the legal IT market

Contact us to find out how we can help. In the unlikely event that we can't, it's most likely we'll know someone who can.

8.1.64 MedBrief

Steven England	
steve.england@medbrief.co.uk +44 (0) 20 3947 8888	
Unit 5 Avenue Terrace, 28 Avenue Road, Birmingham, B6 4DY	
https://medbrief.co.uk	
<p><u>Company Description</u></p> <p>MedBrief was founded in 2017 by three eDiscovery Consultants, two based in the UK and one in South Africa. The Company has been in operation since 2011 but only became a separate entity as a result of an MBO from a large UK based eDiscovery vendor.</p> <p>Since 2017 both the Company and the demand for our services have grown significantly, from an initial team of 5 we now have over 25 staff based between the UK and South Africa and that team is growing all the time. Turnover has increased ahead of expectations and we anticipate that 2019/20 will see this trend accelerate.</p> <p>We are focused solely on the Healthcare litigation industry, providing software and services which assist in the process, distribution and review of medical files and radiology images. Our software is unique - we don't seek to compete with the mainstream eDiscovery review applications, but to compliment them or offer an alternative in circumstances where requirements change.</p> <p>Our software and services are currently being used in over 8,000 clinical negligence and personal injury matters for firms across the UK together with a number of international mass tort and product recall cases for international clients.</p> <p>Our clients come from a range of industries, while most are law firms we also work directly and indirectly with NHS Hospitals, medical product manufacturers and insurance companies.</p>	
<p><u>Vendor Offerings</u></p> <p>MedBrief Secure Review</p> <p>MedBrief is both a Company and a piece of software, we own all of our IP and have an in-house development team. The services we provide focus on improving security an efficiency in healthcare litigation.</p> <p>We are not an eDiscovery company, however we have a deep understanding of eDiscovery having spent many years working within the industry. Our objective is to provide complimentary services specifically in respect of healthcare litigation in circumstances where using traditional eDiscovery software is often not appropriate.</p> <p>The application provides review functionality for both scanned and native document types together with the radiology images that accompany them.</p> <p>In addition to the software we also provide the following services to Healthcare litigation teams:</p> <ul style="list-style-type: none"> • Obtaining of Medical Records hosting and distribution. • Indexing and pagination of Medical Records. • Scanning, pagination and OCR. • Hosting of Medical records, radiology and other documents. • Preparation of medical chronologies, summaries and reports. 	

8.1.65 Media Discovery

Nicholas Tomkinson-Hill	
nick@media-discovery.com 01889 503100	
Church Croft house, Station Road, Rugeley, Staffordshire, WS15 2HE	
www.media-discovery.com	
<p><u>Company Description</u></p> <p>After some 30 years of trading as Media Resources, in 2014 we are re-branding as Media Discovery.</p> <p>Media Discovery is a leading professional tape services organisation, providing tape data restoration services, with specific expertise in identifying and extracting targeted information, for Electronic Data Discovery (e-Discovery), Information Management and Corporate Compliance purposes.</p> <p>Our mission is to work with our customers to reduce the business pressures associated with tape e-discovery and other tape restoration requirements, by providing them with swift access to required data that resides on backup tape media.</p> <p>Our Expertise centres on our ability to restore information from virtually all physical tape formats and logical backup formats. Our services are delivered by highly experienced professionals, with tape specific expertise, in our dedicated and secure Data Services centre.</p>	
<p><u>Vendor Offerings</u></p> <p>Our Solutions, both reactive and pro-active, are designed to deliver significant business benefits when organisations are faced with complex and expensive tape preservation and restoration demands. They include;</p> <ul style="list-style-type: none"> ➤ Tape e-Discovery ➤ Tape Restoration on Demand ➤ Tape Discovery and Remediation ➤ Audio Restoration & Processing <p>Our Processes enable us to swiftly identify, extract, and return required data, residing on backup tape, via the most appropriate methodologies - and are designed to save time, reduce risk and lower the costs associated with such processes.</p> <p>Our Tape Discovery and Restoration services;</p> <ul style="list-style-type: none"> ➤ Incorporate Engineering skills to deliver a highly scalable service. ➤ Utilise efficient workflows. ➤ Are subject to strict media management processes that ensure all data is identified, restored and delivered to the client. ➤ Follow a forensically sound and legally defensible process. 	

8.1.66 Media Resources

Nicholas Tomkinson-Hill	
nick@media-resources.co.uk 01889 503100	
Church Croft house, Station Road, Rugeley, Staffordshire, WS15 2HE	
www.media-resources.co.uk	
<p><u>Company Description</u></p> <p>Media Resources is a leading professional tape services organisation, providing data storage solutions including data restoration services, with specific expertise in identifying and extracting targeted information, for Electronic Data Discovery (e-Discovery), Information Management and Corporate Compliance purposes.</p> <p>Our mission is to work with our clients to reduce the risks, costs and business pressures associated with tape processing environments. We address 3 key areas;</p> <ol style="list-style-type: none"> 1. The supply of tape media. 2. Ensuring the ongoing accessibility of data. 3. The secure retirement of data bearing assets. <p>Our process allows us identify, extract and restore information from virtually all physical tape formats and logical backup formats, without recreating the original environment, therefore allowing access to required data in the fastest possible time and at the lowest possible costs.</p> <p>Whether required for e-discovery or other tape restoration requirements, our services are delivered by highly experienced professionals, with tape specific expertise of over 30 years, in our dedicated and secure Data Services centre, centrally located less than an hour's drive from London.</p>	
<p><u>Vendor Offerings</u></p> <p>Our Solutions, both reactive and pro-active, are designed to deliver significant business benefits when organisations are faced with complex and expensive tape preservation and restoration demands. They include;</p> <ol style="list-style-type: none"> 1. Tape e-Discovery 2. Tape restoration on demand 3. Tape discovery and remediation 4. Audio Restoration and Processing <p>Our Tape Discovery and Restoration services;</p> <ul style="list-style-type: none"> • Incorporate Engineering skills to deliver a highly scalable service. • Utilise efficient workflows. • Are subject to strict media management processes that ensure all data is identified, restored and delivered to the client. • Follow a forensically sound and legally defensible process. 	

8.1.67 Millnet Document Services

Steve Chadd Managing Director	
T: +44 (0) 207 422 8841	
M: +44 (0) 7584 482 750	
E: steve.chadd@millnet.co.uk	
6-7 Princes Court, 11 Wapping Lane, London, E1W 2DA	
www.millnet.co.uk	
<p><u>Company Description</u></p> <p>Millnet Document Services is the one of the largest and longest serving Document Services businesses in the heart of London.</p> <p>Incorporated in 1996, Millnet Document Services boasts a wealth of experience and an enviable client base. Working with Legal 500 firms and FTSE 100 companies, our legal and corporate clients testify to our first class performance in offering an impressive range of services under one roof.</p> <p>Combined, we have over 250 years of experience in the document solutions industry. Our varied client base relies on our ability to leverage this experience to provide a consultative approach to meeting their requirements, rather than just a one size fits all offering. Our 57 staff are highly trained in delivering innovative solutions and we are uniquely positioned to take a client problem, whether that be of space, cost, timeline, or even the necessity of a complete process overhaul, and provide a bespoke, process-driven solution.</p> <p>At Millnet Document Services we deliver cutting edge technology with traditional client support.</p>	
<p><u>Vendor Offerings</u></p> <p>We are a global enterprise with a local infrastructure, capable of assisting clients in over 60 countries around the world. Our experts are perfectly situated to assist in any project, including live or onsite scanning, reprographics and electronic data printing.</p> <p>Photocopying</p> <p>We provide a wide range of outsourced photocopying and related services. Housing cutting edge technology our impressive production facilities are capable of handling photocopying jobs of any size 24/7.</p> <p>Scanning and Indexing</p> <p>We have extensive experience in delivering major document scanning projects, accurately, confidentially, and to the tightest deadlines. We specialise in high volume scanning projects that must be delivered to exacting quality standards. As a company, we started in legal assistance but have now grown into a multi-vertical company that assists corporations, law firms and other professional service firms with their document service needs. We scan to TIFF, PDF and many other formats and create load files for all the leading document management and litigation support packages.</p> <p>On Location Support</p> <p>We assist clients' print, index, and bundle projects worldwide, in-keeping with international laws and parameters. We not only have the capability to assist clients close to home, but around the globe. Where a case crosses international borders</p>	

paper evidence from another jurisdiction may need to be included – our mobile scanning services offer the best solution where cost and/or security implications prohibit original documentation from being shipped out of their place or country of origin. From our headquarters in London we can assist with onsite scanning anywhere in the world.

Bundle Preparation

We take the stress out of bundle preparation so that clients can meet tight deadlines. Regardless of any last minute changes, you can be confident that the end product will be fit for purpose. Our up-front, process driven, rigorous workflow assessment of your bundle requirements results in certainty of price and gives you the confidence that your needs will be met, while cutting out the confusion and constant changes that are common in this service. We also have the legal expertise of our pool of managed reviewers for production and quality control of even the most complex legal bundles, providing you with peace of mind.

DocBuster®

Our solution for batch printing, DocBuster® is powerful, fast and user friendly, taking the headache out of printing electronic documents. Developed in response to commercial law firms' requirements and implemented in many of the leading law firms, DocBuster® is the definitive batch printing solution.

Digital Print

We provide high-end digital print and document finishing services across London to a broad client base spanning multiple market sectors. As part of our digital offering, we own a top of the range iGen 150 digital press, along with a Canon 10000 Imagepress both capable of producing astonishingly high quality print not only at regular 'A' sizes, but also larger flat sheet sizes up to 660 x 364 cm.

Our Security and Certifications:

- ISO27001 (2013)
- ISO9001 (2015)
- ISO14001 (2015)
- FSC Certified

8.1.68 Milyli (US)

Mark Neace, Director of Sales	
mark@milyli.com +1 (312) 265-0136	
415 N Sangamon St., Chicago, IL 60657	
www.milyli.com	
<p><u>Company Description</u></p> <p>Milyli – which stands for “Make it like you like it” – is an eDiscovery software development firm with over eight years’ experience providing eDiscovery solutions to leading law firms, service providers, government organizations, and corporations. Founded in 2008, we were the first software firm to develop on top of kCura’s Relativity platform, making us the experts in Relativity customizations and integrations. This experience has allowed us to gather real-world insight about what eDiscovery professionals need to make the review process go smoothly. With that insight, we’ve developed a suite of ready-to-install eDiscovery applications that address common pain points in the review process, like tedious manual redaction workflows, and ensure the most accurate and cost-effective review.</p> <p>We’ve also built scores of custom Relativity solutions to integrate third-party applications or systems into Relativity, automate troublesome parts of the review workflow, and bring new functionality into Relativity with applications built from scratch. We have seen it all, built it all, and can take on any project you can dream up to make Relativity work for you.</p>	
<p><u>Vendor Offerings</u></p> <p>Milyli software products integrate seamlessly into Relativity to help with Review and Analysis.</p> <ul style="list-style-type: none"> • Blackout is the easiest, most comprehensive way to redact information in Relativity. With Blackout, reduce review time, lower costs, and create workflows that increase accuracy. • Broadcast provides the most meaningful reporting for Relativity users who need to measure data points across workspaces and clients. With Broadcast, build granular reports on almost any information recorded in Relativity and pull in additional data to uncover even more insights. • Chronicle is the easiest way to build privilege logs in Relativity. With Chronicle create a consistent, defensible narrative while reducing the expense and time it takes to construct a privilege log. • Delegate is the most robust admin tool for Relativity. Delegate allows Relativity hosts to create user and group level access settings for specific workspaces and matters—all within the same instance. • <p>Customizable Technologies:</p> <p>Milyli supports any stage of eDiscovery with Relativity-compatible technologies that meet the highest standards of functionality, reliability, usability, and efficiency.</p> <ul style="list-style-type: none"> • Relay allows Relativity users to import documents and data directly from SQL-based systems into their instance without load files. • Bridge provides a framework to automate the movement of case data and work product from Concordance and Summation into Relativity — including data not typically supported by load files. 	

- **Ditto** saves Relativity users time and effort by replicating user permissions across workspaces or between groups in the same workspace.
- **Script Runner** allows Relativity users to automate the execution of Relativity Scripts found in the Relativity Script Library at the time(s) and frequency of their choosing.
- **Task Manager** is a project management tool that allows users to manage day-to-day Relativity operations with ease, all without ever leaving Relativity.
- **Licensing Manager** allows users to issue software licenses to customers without having to build the infrastructure necessary to maintain a licensing service.
- **ARM for Delegate** provides Delegate users access to ARM, Relativity's official workspace migration tool. Use all of Delegate's permission granting capabilities to allow clients to archive and restore workspaces.
- **Custom Development and Developer Education** to assist with software integrations, infrastructure challenges, workflow improvement, and more.

8.1.69 Morae Global

Magnus Becher	
magnus.becher@moraeglobal.com +44 (0) 7852 746 771	
Hasilwood House, 60-64 Bishopsgate, London EC2N 4AW	
https://www.moraeglobal.com/	
<p><u>Company Description</u></p> <p>Morae Global Corporation provides end-to-end legal and compliance solutions. Morae’s team of experts is comprised of some of the most seasoned and knowledgeable professionals in the legal industry who are trusted to transform legal and compliance departments worldwide.</p> <p>Core service lines include CLUTCH Information Management & eDiscovery; Legal & Compliance Consulting Solutions; and Alternative Legal Services. Using performance-based management consulting and technology-enabled information, discovery, and on-demand legal services, Morae Global is redefining the business of law.</p> <p>Morae Global has offices throughout the United States, including in Houston, Chicago, New York and Washington, D.C., and internationally in London, Zurich, Bangalore and Hong Kong.</p>	
<p><u>Vendor Offerings</u></p> <p>CLUTCH Information Management & eDiscovery</p> <p>Evolving business regulation and exponential growth in data have created enormous legal challenges. Our many technology-enabled solutions apply sophisticated and proven processes to help your legal and compliance teams quickly and proactively address litigation, regulatory and internal investigations; effectively identify and shape your response to key risks; and drive efficiency for the company and its outside counsel.</p> <p>Policy Design and Implementation</p> <p>Challenging the typical EDRM-based linear approach, our professionals rely on early analytics, streamlining document reviews and minimizing required resources throughout the project. Our methodology is designed to leverage predictive coding and other analytical tools to minimize volume, cycle time and cost while increasing measurable quality. Our professionals develop strategies based on particular experiences using tried-and-tested technologies, resulting in custom, cost-effective solutions and optimum performance.</p> <p>Legal Hold Management</p> <p>We apply a programmatic approach that meets legal requirements that can be performed consistently and efficiently, and demonstrates defensibility through auditing and reporting. Our team specializes in designing and implementing technology and processes, reporting and change management. We serve as expert advisors and provide 360-degree support before, during and after implementation using industry best legal hold technologies including Exterro’s Legal Hold, IBM’s Atlas, Zapproved’s Legal Hold Pro and Relativity Legal Hold, as examples.</p> <p>Forensic Collection</p> <p>We have a Global network of data collection experts with decades of experience ready to be dispatched 24/7 to support you and your teams. Our team is attuned to local collection and data protection laws to collect in a sound and defensible manner. We use quick data extraction and proven collection methodologies across every data format or device. Every collection option is catered to: In-Person, Remote and Self-Collection. We assist in the</p>	

recovery of deleted files, password cracking and online email recovery. Our experts examine Microsoft Windows registry, search engine and browser history. Also, last file access, changes and deletion; phone logs and mobile phone evidence is examined. We deploy state of the art technology to support your data recovery efforts and compile a comprehensive report on results.

Data Processing & Hosting

Our Data Analytics team has dozens of processed petabytes of data sourced from every major enterprise data source for thousands of workspaces. We are technology agnostic, meaning we've used all leading eDiscovery processing tools to ingest data into a wide variety of review platforms. We host data in our US or European servers, depending on client or project requirements, and were the first company in the world to be a RelativityOne Certified Partner in the UK. There is not a data type or source we haven't processed and hosted.

The new ClutchCumulus platform is our managed service offering built around RelativityOne and hosted in the Microsoft Azure Cloud. ClutchCumulus is entirely Office 365 ready and offers rapid scalability with state of the art security at low cost, enabling corporate law departments and law firms of every size to meet their data management needs.

We take pride in industry-leading processing through-put of up to 300 Terabytes per day as well as our capability to develop customized processing workflows.

Data Migration

With increasing regularity, clients are asking Clutch to migrate entire data instances held by other eDiscovery vendors into our environment. Clutch recently migrated one of the largest financial sector entities and one of the largest oil/gas sector entities, both of which included top-fold, high-stakes matters in the transfer.

Managed Document Review – Substantive & Privilege

Our world-class project managers have overseen the most complex investigations and litigations in modern history. A key differentiator is our focus on understanding subject matter and implementing those insights into project execution with a heavy emphasis on technology solutions.

We help to build the review population by first gaining subject matter understanding, applying advanced analytics for early fact discovery, defining the review population and executing an informed approach. We triage to review in smart batches. This step includes privilege triage, which reduces the risk that privileged documents are missed. Technology and substantive expertise are the foundation for our multi-pronged QC approach. Finally, deliverables and reporting to bring greater meaning to our clients through reports such as Monthly Details & Spend, Daily Status, Issue Summary and the Key Documents Chart.

We offer managed review services in our ISO certified centre or on client site and routinely accommodate foreign language review including but not limited to Arabic, Bulgarian, Chinese, Czech, Danish, English, French, German, Hebrew, Hindi, Italian, Japanese, Norwegian, Polish, Portuguese, Russian, Spanish, Swedish, Vietnamese. Other languages upon request.

Workflow Development & Special Projects

Clutch is adaptable to deploying differing workflow, from the simple search terms, threading, and review, to more nuanced workflows that leverage analytics or subject matter insight. Our workflows improve accuracy and pace, front load the discovery of matter-critical content, and help clients avoid costs.

As a specific example, we developed a custom workflow to perform trade reconstruction as required by Dodd-Frank or MIFID on an expedited basis. Furthermore, we're able to create trade chronologies using our custom developed chronology tool that automates the data sourcing from review and facilitates user supplementation.

GDPR and Data Protection

GDPR ushered in an assortment of regulations mandating, among other requirements, that entities understand the contents and interworking of their business and customer agreements. Capture.IQ is our solution to automating that effort with robust QC workflows overseen by industry experts. Capture.IQ leverages unstructured data analytics to extract key contract data points. Automated extraction is underpinned by our industry-specific computer programmers and is subject to validation designed to ensure accurate capture approaching 99 percent.

Advanced Analytics and Predictive Modelling

We are adept in the application of advanced clustering, concept searching, categorization, communications analysis, and other unstructured analytics in matters. Beyond the mere administration of these tools (e.g. Brainspace), we counsel clients in their strategic application as well.

Clutch is often engaged to manage predictive modelling, the machine-learning scoring of a dataset by relevance-likelihood based on input from a subject matter expert. We leverage Continuous Active Learning and multi-lingual advanced analytics in every major language, including all European languages, Chinese, Farsi, Korean and Japanese.

Redaction

Clutch helps clients to redact sensitive or confidential data in disclosure to external parties. We're equipped to deploy Blackout, an automated redaction tool that plugs in directly to Relativity and saves time and money in the redaction workflow.

Production

We have produced to every major regulator in the world and countless private third parties. Our robust production QC processes ensure that we disclose only what client and counsel intend and that production is delivered promptly according to specification.

Legal & Compliance Consulting Solutions

Our clients call us outsiders with an insider's perspective. Our uniquely constructed team includes consultants with decades of experience, as well as former general counsel, law department operations professionals and law firm attorneys. We leverage our real-life experience to help transform your legal and compliance functions into nimble, innovative results-driven teams.

Alternative Legal Services

We serve as an extension of your legal and compliance function by deploying skilled and experienced attorneys, paralegals and other professional resources—including process experts, data analysts, and technologists—to help accelerate key initiatives while balancing cost, quality and risk. Legal professionals from our deep and diverse bench can be procured individually or as a managed service, using predictable pricing models, and can be flexed up or down based on business needs. There is no need to increase headcount or infrastructure, or rely on expensive outside counsel.

Clutch has performed a critical role in supporting clients to comply with GDPR. We have onsite experts deployed to oversee aspects of GDPR change management programmes.

8.1.70 Netmaster Solutions Ltd / CaseLines

David Jackson	
david.jackson@netmastersolutions.co.uk +44 7827 999669	
Portland House, Bressenden Place, London SW1E 5RS	
www.caselines.co.uk	
<p><u>Company Description</u></p> <p><u>CaseLines delivers:</u></p> <ul style="list-style-type: none"> • Cost effective evidence bundling and electronic presentation of evidence (EPE) • Secure, multi-party collaboration • One-click streaming of video evidence • Instant on-demand virtual hearings <p>CaseLines delivers instant benefits to litigators, general counsel and clients. CaseLines simplifies bundle preparation and lowers cost. It allows counsel, judges, court staff and lawyers to work on the same set of documents at an early stage, and to do so securely and remotely. And it saves carbon – for one large client the saving is equivalent to 2,000 trees per month.</p> <p>CaseLines is used in courts throughout the UK and in the UAE and Africa. The system has been used for over 250,000 cases and holds 65m pages of evidence.</p> <p><u>CaseLines</u></p> <ul style="list-style-type: none"> • is the market leading service for the preparation of legal bundles and electronic presentation in the courtroom. • reduces the time and effort required to prepare legal bundles, eliminates the direct and indirect costs of paper and allows courtroom presentation of the bundles without the added cost of a courtroom operator. • eliminates the need to pay for third party preparation of digital bundle files. • provides a secure and easy-to-use cloud based service to collaboratively produce, present and review high quality professional legal bundles, from the office or any remote location. <p>CaseLines has been providing evidence bundling and courtroom presentation services for litigators since 2010. We now have unrivalled experience supporting litigators with cases of all possible sizes, from 100 page criminal cases to 100,000 page group litigation cases, with everything in between.</p> <p>In 2016, CaseLines developed two major firsts in the digital courtroom space – one-click video streaming, allowing body worn camera evidence to be stored and streamed to court – and language localisation, allowing the CaseLines service to be offered in 6 languages, with more planned.</p> <p>In 2017, CaseLines delivered instant, on-demand virtual hearings, with recordings stored in the evidence file for subsequent review. CaseLines also introduced AI-driven fuzzy matching to detect duplicate and near duplicate documents in the evidence bundle. In late 2017 we announced the launch of a case management API and now have multiple CMS API's in place.</p> <p>In 2018 CaseLines introduced the ability to apply redactions across specific bundles associated with a case and to make available to relevant parties only the redacted version of a document. The solution retains both unredacted and redacted versions of each document for visibility to parties subject to appropriate permissions. Appropriate users (for instance a judge, or the managing lawyer) can see superimposed on an unredacted version of a</p>	

document the exact position of redactions in the redacted version and the sub-bundles in which the redacted version is filed.

Also in 2018 CaseLines introduced enhanced search tools, including handwriting search plus Boolean, proximity and fuzzy matching based on an AI machine learning system

In 2019 CaseLines introduced functionality allowing lawyers to

- load evidence files directly from discovery databases such as Summation
- mark up and annotate files using stylus/pen tools
- automatically transcribe recordings of hearings and other audio/video recordings

Vendor Offerings

CaseLines is a secure web-based service that allows legal teams to collaborate on any legal content – mediation or trial bundles, deal bibles, contract packs etc. CaseLines gives the team online access to a secure shared workspace, without the hassle or cost of setting up a separate data room, which can be accessed from anywhere in the world. It saves the trouble and cost of regularly re-issuing pdf bundles every time the contents change or re-printing hard copy sets. Key features include:

- Hosting of trial bundles and evidence documents with remote online access
- Automatic indexing and hyperlinking
- Dynamic hyperlinking of opening/closing submissions to bundle documents, or from witness statements to exhibits
- Private or shared annotations which ‘stick’ to the correct page in the bundle even when pages are added or moved around
- One-click streaming of audio and video evidence or recordings of the hearing
- Instant on-demand virtual hearings and video conferencing, with the ability to store a recording in the case file
- Multiple bundles, with access managed at the sub-bundle level, allowing mini-bundles to be created for juries, expert witnesses etc.
- Automatic duplicate detection using AI fuzzy matching

CaseLines is used by civil litigators, public law lawyers for child protection and adoption cases and by private and public prosecutors, including a wide range of criminal cases. Over 1,000 judges in the UK have been trained to use CaseLines.

Netmaster Solutions is certified to ISO 27001 for Information Security Management. Case data is stored in Tier 1 datacentres and uses encryption for data in transit and, optionally, at rest. CaseLines improves management of security over case files with audit trails showing who has accessed any case or document and when. The alternative, without CaseLines, is that users must rely on paper or sending documents by email. However, paper can be lost or misplaced, and has virtually no effective audit trail. Even sending documents (such as a pdf bundle) by email is far less secure than CaseLines, since documents are very commonly sent via unencrypted email, and there is no subsequent audit trail to allow enforcement of the security provisions.

8.1.71 NightOwl Discovery (Ireland)

Michael Conner	
mconner@nightowldiscovery.com	
Mob : +1 415-694-1239 Land: +1 650-484-9050	
Suite 333, The Capel Building Mary's Abbey, Dublin 7	
www.nightowldiscovery.com	
<p><u>Company Description</u></p> <p>NightOwl was founded in 1991, and offers a complete spectrum of discovery services, including full spectrum discovery management, analytics, review management and litigation/discovery consulting to organizations in demanding industries such as life sciences, finance and construction. Historically, we have worked on some of the largest litigation matters, including most recently an on-going life sciences product liability MDL that includes more than 25 million documents. Large-scale defence experience also includes global oil spill litigation, the silicon breast and penile implant class actions, U.S. tobacco litigation and major lead and asbestos litigations.</p> <p>NightOwl is a privately-owned US company headquartered in Minneapolis, MN with offices across the US and Europe. NightOwl Discovery Global is a wholly owned subsidiary headquartered in Dublin, Ireland. NightOwl has four major divisions: Discovery Management (discovery services spanning entire EDRM), Review Management (fully managed contract attorney review), Technology Consulting (supporting client-owned discovery systems) and Business Solutions (onsite staffing services).</p> <p>NightOwl has grown at an average compound annual rate of more than 25% over the past 5 years. We are currently a top-15 global discovery management provider. Our strong growth over the past five years is attributed to the strong service, expertise and unique elements that NightOwl brings to engagements.</p>	
<p><u>Vendor Offerings</u></p> <p>The following areas distinguish NightOwl in the industry as we continue to grow year over year:</p> <ol style="list-style-type: none"> 1) Deep integration with clients – NightOwl seeks long lasting engagements with quality clients. We onboard fewer than one new client per month and yet our revenues have grown by double digits for over eight years straight. We have not lost a single discovery management client. We believe that this is due to our commitment in taking the long-term view with each of our clients. We work hard at the outset of relationships to build a deep partnership with our clients. We become part of our clients' discovery management solution rather than act as an outside vendor. 2) Innovative programs – NightOwl is a leader in innovative discovery management programs. NightOwl nVision®, our most popular program, offers clients a flat monthly fee program that includes processing, hosting, analytics and production, along with a dedicated client team. The programs are flexible and can be configured to match your current and future needs. Other programs, such as nTerprise® seek to maximize existing client investments in behind-the-firewall discovery technology by supporting that technology and integrating it with off-premises hosting and review solutions. 	

We have an efficient program for every client with a significant and ongoing discovery management need.

- 3) **Full discovery spectrum** – NightOwl is one of the few providers that offers a full spectrum of discovery services, including services in information governance, legal hold notification and preservation, collection, processing, hosting, production, managed review, paper discovery (imaging), and US/EU/APAC data centers. We are a full-service discovery company expected by our clients to handle all aspects of discovery, including elements such as workflow planning, training and education for in-house and outside counsel, and interfacing with corporate IT resources.

- 4) **International data centers** – NightOwl operates our own international data centers in Dublin (Ireland), Dusseldorf (Germany) and Hong Kong (China). These data centers are built to the same specifications as our secure US data centers, including two-way failover capabilities in the EU data centers. In addition to international data processing and hosting, we also offer Managed Review services in Dublin (Ireland) and Dusseldorf (Germany) and project management in Ireland, Germany and UK.

- 5) **Woman-owned business** – NightOwl is a certified woman-owned business by the Women's Business Enterprise National Council (WBENC). Certification is a rigorous, multi-faceted business application and review process, conducted by the Certification Review Committee. WBENC certified businesses are nationally recognized and accepted by major corporations and government entities.

8.1.72 Nuix Technology Ltd

Samantha Mather	
Samantha.mather@nuix.com +44 795 127 1978	
Times House, 2nd Floor South, 5 Bravingtons Walk, London, N1 9AW	
www.nuix.com	
<p><u>Company Information</u></p>	
<p>Nuix provides critical data intelligence solutions that enable organizations to seamlessly collect, protect, manage, and interrogate their structured or unstructured data— particularly human and human-behaviour generated data.</p>	
<p>Nuix is built on a history of stability and growth:</p>	
<ul style="list-style-type: none"> • Commercialized in 2006, profitable since 2008 • More than 400 employees worldwide • 2,000+ satisfied customers, 250+ new in 2017 • Customers and partners in 70+ countries • Acquired Ringtail in 2018 	
<p>Nuix is the only data and analytics platform that helps organizations tackle critical challenges across the total threat continuum and the entire data lifecycle— on premises or in the cloud. The Nuix Engine can turn raw data into contextualized information across more than 1,000 formats and source types, much faster and more scalable than competing technologies. With rapid availability, advanced automation, and intuitive visualization, Nuix and our partners deliver solutions that are transforming the ways organizations anticipate, detect, and act on cybersecurity threats, litigation and eDiscovery, risk and compliance, intellectual property theft, and much more.</p>	
<p><u>Vendor Offerings</u></p>	
<ul style="list-style-type: none"> • Nuix Ringtail is an industry-leading legal review and visual analytics tool acquired by Nuix in 2018. Fully integrated processing, review, analytics, and predictive coding technologies help you uncover better evidence, faster, and quickly make it part of your case strategy. Ringtail is available in SaaS, on-premises and hybrid configurations directly from Nuix. • Nuix Workstation is the world’s leading technology for extracting intelligence from high-volume unstructured, semi-structured, and structured data. It provides unmatched speed, scale, and accuracy to processing, searching, indexing, and analyzing the information you need. • Nuix Web Review & Analytics is a web-based, collaborative, forensic investigations tool in which to share, search, and analyze case data. Powerful visualizations and a simple web interface enable investigators to analyze quickly and arrive at a case position sooner. • Nuix Enterprise Collection Center performs data collection, relocation and production from many devices and storage platforms, across disparate, remote, and difficult-to-access sources. 	

- **Nuix Legal Hold** is a preservation and custodian notification tool that maximizes the use of technology and automation to meet legal hold obligations in eDiscovery. It eliminates tedious manual intervention and provides a complete audit trail to maximize defensibility.
- **Nuix Adaptive Security** is an EDR tool that delivers a proactive approach to detecting an ongoing attack, accelerate recovery time, easily adapt to changing environments, regulations and attack vectors—and ultimately stop incidents in their tracks.
- **Nuix Analytics & Intelligence** is a dynamic, collaborative investigations tool that makes it possible to quickly extract, correlate, and contextualize thousands of data types—across people, objects, locations, and events—enabling investigators to make faster and more accurate decisions and accelerating investigations.
- **Nuix Orchestration** is a web-based multi-user graphical tool that allows you to map out complex data processes across multiple activities and machines and lets them run with minimal user input. Optimize resource utilization, manage changing priorities, and maintain consistent workflows.

8.1.73 Omnis

Ben Gowers			
bgowers@omnisglobal.com +44 (0)7544 743666			
City Pavilion, 33 Britton Street, London, EC1M 5UG			
www.omnisglobal.com			
<p><u>Company Description</u></p> <p>Omnis is a new breed of global service partner to the legal and compliance sectors. With offices in Dubai and London we provide an unparalleled service in round the clock document and data management services, for a growing list of high profile clients.</p> <p>We are one of very few companies focusing on the Middle East region and were the first independent to enter the UAE Electronic Discovery market in 2014. In the UK, we are focused on applying innovative new approaches to assist companies with their ever emerging Information Governance challenges.</p> <p>Our team is made up of technology experts from leading consulting firms, who are knowledgeable in multi-jurisdictional and cross-border matters, including applicable Middle East, UK and US legal processes.</p> <p>Founders Ben Gowers and Nigel Murray have a wealth of experience in this sector, having built multiple successful businesses in the past. Their previous venture together, Trilantic, was sold to Huron Consulting in 2010.</p>			
<p><u>Vendor Offerings</u></p> <p>Our technology experts and solutions help organisations maximise the value of their information while minimising associated risks and costs.</p> <p>Our practice areas are focused on Disputes, Investigations and Corporate Governance.</p> <p>Our services consist of the following:</p> <table border="0" data-bbox="268 1279 1316 1630"> <tr> <td data-bbox="268 1279 790 1630"> <p><u>Electronic Discovery</u></p> <ul style="list-style-type: none"> ● Digital Forensics / Collections ● Electronic Data Processing ● Electronic Review & Disclosure ● Legal Process Outsourcing ● Paper Bundles, Scanning & Coding </td> <td data-bbox="805 1279 1316 1630"> <p><u>Information Governance</u></p> <ul style="list-style-type: none"> ● File Analysis & Risk Evaluation ● Intelligent Migration ● M&A Due Diligence / Divestiture ● eDiscovery Optimisation ● Maturity Assessment & Strategy </td> </tr> </table> <p>We use best of breed software, including EDT for Electronic Discovery and Nuix for Information Governance.</p>		<p><u>Electronic Discovery</u></p> <ul style="list-style-type: none"> ● Digital Forensics / Collections ● Electronic Data Processing ● Electronic Review & Disclosure ● Legal Process Outsourcing ● Paper Bundles, Scanning & Coding 	<p><u>Information Governance</u></p> <ul style="list-style-type: none"> ● File Analysis & Risk Evaluation ● Intelligent Migration ● M&A Due Diligence / Divestiture ● eDiscovery Optimisation ● Maturity Assessment & Strategy
<p><u>Electronic Discovery</u></p> <ul style="list-style-type: none"> ● Digital Forensics / Collections ● Electronic Data Processing ● Electronic Review & Disclosure ● Legal Process Outsourcing ● Paper Bundles, Scanning & Coding 	<p><u>Information Governance</u></p> <ul style="list-style-type: none"> ● File Analysis & Risk Evaluation ● Intelligent Migration ● M&A Due Diligence / Divestiture ● eDiscovery Optimisation ● Maturity Assessment & Strategy 		

8.1.74 OpenText Discovery

Simon Price	
simonp@opentext.com +44 20 3627 5011,	
Princes Court, 7 Princes Street, 4 th Floor, London, EC2R 8AQ	
www.opentext.com	
<p><u>Company Description</u></p> <p>OpenText enables the digital world, creating a better way for more than 100,000 organisations to work with information, on premises or in the cloud. As a global leader in Enterprise Information Management, our products enable businesses to grow faster, lower operational costs, and reduce information governance and security risks. OpenText was founded in 1991 and currently employs 12,000 staff in 80 offices worldwide. For more information about OpenText (NASDAQ: OTEX; TSX: OTC), please visit: www.opentext.com.</p>	
<p><u>Vendor Offerings</u></p> <p>OpenText EnCase</p> <p>EnCase is the world’s most widely used and trusted forensic collections tool—capable of targeting specific files or capturing entire disks for defensible preservation and processing into review platforms, like Axcelerate and Insight (through the acquisition of Catalyst Repository Systems in January 2019). Deployed on over 42 million endpoints, EnCase enables forensically sound and discrete collections from workstations (e.g., laptops, desktops, phones), ECM solutions (e.g., Microsoft, OpenText, Box), and more. EnCase even supports automated, offline collections with an enhanced agent that automatically starts and stops transfers as devices are connected or disconnected from the network. EnCase maintains evidence consistency and integrity with its proprietary Logical Evidence File (LEF) format, which accurately preserves all original data as an image file and has been examined and upheld by numerous courts around the world.</p> <p>OpenText Axcelerate</p> <p>Axcelerate is an end-to-end eDisclosure solution with integrated advanced analytics and machine learning (including multiple forms of machine learning and TAR features). Axcelerate’s analytics are developed in-house, producing rapid search results and a seamless user experience that helps legal professionals prioritize the review of important documents with the assistance of AI. In addition to keyword search, phrase analysis, and metadata filtering, Axcelerate includes integrated visualisations and communication mapping tools. It also features industry-leading machine learning capabilities that automatically organise documents according to conceptual similarity and continuously learn from human decisions to identify similar content. In addition to a full-suite of workflow automation and document production tools, Axcelerate also includes advanced pattern recognition capable of automatically identifying and redacting PII like credit cards, phone numbers and more. All this functionality is built in to the technology (no 3rd party add-ons or integrations) and is available to use all the time.</p> <p>OpenText Insight Legal Hold & Collect</p> <p>Insight Legal Hold & Collect is proven, defensible legal hold technology with centralized and automated hold management from a single pane of glass across the enterprise. Hosted securely in the cloud, Insight Legal Hold & Collect can be deployed quickly, with no hardware requirements, and integrate with various corporate systems including email, IT, and HR. Insight Legal Hold & Collect can</p>	

create and distribute targeted legal hold notices rapidly with web-based questionnaires, audit trails, and the ability to automate IT task suspensions to prevent inadvertent data spoliation. Integrated remote collection capabilities are also available.

OpenText Insight Discovery

Available in the United States and Japan via a cloud model, Insight Discovery is a full EDRM platform purpose-built for multi-matter management. Documents can be collected, processed and reviewed once, stored centrally and promoted as often as needed for analysis, review and productions--effectively reusing work product. Analytics, machine learning automated workflow to help legal teams review eDisclosure and investigations data and documents with speed and accuracy. Specific review features include multi-modal search, visual analytics and social networking, automated pattern detection and redaction of sensitive data, dynamic review workflow, paging and highlights, automated data management from loading and processing to production, and user-controlled automation. Insight allows users to process, search, analyse and review in more than 280 languages, including Chinese, Japanese and Korean (CJK). Insight Discovery integrates with Insight Legal Hold & Collect and Insight Predict machine learning based on the continuous active learning protocol, to prioritize reviews.

OpenText Discovery Services

OpenText Discovery software can be installed on-premise, accessed via your own secure private cloud or on a project by project basis. OpenText is the only company that can offer technology and professional services across multiple delivery models. In addition, OpenText complements the technology offering with a fully staffed first-party professional services team to ensure that clients get the maximum benefit out of technology investments including:

- **Data Collection** - a dedicated team from OpenText using OpenText and other industry standard technology to collect data from multiple data sources within corporations on a project by project, or subscription basis.
- **Mobile Discovery** - OpenText EnCase and OpenText Axcelerate in a 'box' supported by our professional services teams when data cannot leave site or jurisdiction.
- **Project Management** - our team of experienced project managers have an average of 10 years' experience in eDisclosure and have worked on hundreds of projects across multiple jurisdictions, including data subject access requests (DSAR), litigation and arbitration reviews as well as large scale investigations. OpenText project managers work in a consultative manner and ensure every workflow they design fits the goals of your project, and the needs of your client.
- **Machine Learning/TAR** - our team of TAR experts, including data scientists, search experts, lawyers and technologists, can develop optimal workflows to meet client goals in the most efficient and cost-effective manner.
- **Technology Implementation** - our professional services team can provide the full suite of services required to implement Axcelerate On-Premise within your organisation or integrate our Axcelerate Cloud solution into your internal litigation support service.
- **Managed Services** - our team can provide onsite or remote managed services to manage on-premise software technical installation and/or manage on-going eDisclosure projects with your internal legal teams.

8.1.75 Opus 2 International

Oliver McClintock	
omclintock@opus2.com +44 20 3008 6611	
5th floor, 5 New Street Square, London, EC4A 3BF	
www.opus2international.com	
<p><u>Company Description</u></p> <p>Opus 2 International is a court reporting and litigation software development company founded by Graham Smith-Bernal, the creator of LiveNote. Opus 2 provides cutting edge technology globally, with an emphasis on high quality services delivered though the cloud based software Opus 2 Magnum and Magnum Realtime.</p>	
<p><u>Vendor Offerings</u></p> <p>Opus 2 Magnum – a proprietary document management and electronic bundling tool which has made paperless trials a reality and is revolutionising the way in which lawyers access, share and manage their documents in the trial preparation phase and beyond. A versatile tool – Magnum can be used at any stage of the litigation/arbitration lifecycle.</p> <p>Opus 2 Magnum Realtime – a court transcription tool that allows access to the live feed of proceedings as the action unfolds. Realtime is a highly secure, sophisticated portal to your live hearings. Whether they occur in a nearby courtroom or an arbitration centre in another hemisphere, you may access the entire live proceedings from anywhere – not just from within the hearing room. At the conclusion of the day’s session, Opus 2 synchronises the audio from the live session to the final transcript, allowing all participants to log in and re-live any moment from the day’s proceedings.</p> <p>Electronic Presentation of Evidence (EPE) – any evidence called in the hearing room will be instantly displayed on any number of screens controlled by our experienced EPE officer. If used in conjunction with Magnum, individuals will be able to gain immediate access to their own versions of the documents (with all annotations) alongside the full, clean version of the document that is shared throughout the hearing room.</p> <p>Alongside the services listed, all clients will be given a dedicated, experienced Project/Case Manager who will act as a primary point of contact, providing consultative services throughout the client’s hearing and ensuring that the transition from a paper to electronic trial bundle runs efficiently and exceeds client expectations.</p>	

8.1.76 Planet Data Solutions (US)

<p>David S. Cochran (Chief Operating Officer & Executive Vice President)</p>	
<p>DCochran@PlanetDS.com +1 412 638 7423</p>	
<p>555 Taxter Road – Suite 150 – Elmsford, NY 10523</p>	
<p>www.PlanetData.com</p>	
<p><u>Company Description</u></p> <p>Planet Data provides the best patented technology, Project Management, and consulting expertise to quickly get your eDiscovery job done right- the first time! Our clients run the spectrum from AmLaw 100 firms, midsize firms, corporations, to boutiques and government agencies. The size of an IT department should not be a deciding factor in your litigation needs. When the case demands it, we are your full-service IT department on-demand. We offer a team of dedicated eDiscovery experts who helped build and design the Exego® platform to give you a strategic advantage.</p> <p>We are retained by our clients to provide solutions for:</p> <ul style="list-style-type: none"> • Second/ITC Requests • Cross-Border Disputes • Patent Infringement • Securities Litigation • Employment Litigation • Mergers & Acquisitions • Governmental & Internal Investigations • Bankruptcies • Environmental Litigation • Contract Review <p>Planet Data designed and built the dual-patented Exego® Platform to handle your data like no other engine can. Exego® increases the accuracy of eDiscovery while reducing the total project cost.</p>	
<p><u>Vendor Offerings</u></p> <p>Planet Data addresses today's eDiscovery challenges that must be solved by a combination of cutting-edge technology, forward-thinking expertise and dedicated client-service teams. We have assembled some of the best people in the industry to work for you. Our world-class developers, dedicated hosting team, and squad of expert project managers have hundreds of cases under their belts, and bring a passion for problem solving to the table.</p> <p>Our Services include:</p> <ul style="list-style-type: none"> • Forensic Data Collections & Examination • Mobile Device Discovery & Examination • Exego Extract eDiscovery Processing • Contract Intelligence and Analytics • Exego® Early Case Assessment & Pre-Review Analytics • Secure Data Hosting • Relativity® Review • Managed Document Review • Translation Services • Managed Services – Domestic & International 	

8.1.77 PwC LLP

Umang Paw, Head of Digital & Forensic Investigations Matt Joel, Director, Digital & Forensic Investigations	
umang.paw@uk.pwc.com +44 (0) 7931 304 666 matt.joel@pwc.com +44 (0) 7809 552 273	
1 Embankment Place, London, WC2N 6RH	
http://www.pwc.co.uk/forensic-services/forensic-technology-solutions/	

Electronically-stored information is growing faster than most organisations’ ability to manage it. Typical information systems often hold vast amounts of data but are not designed to respond to critical incidents that create an immediate need for specific data to be preserved, analysed and produced.

The Forensic Technology team at PwC helps clients to manage their electronic data and navigate the legal and business processes that are mandated by critical events ensuring quality at every stage and minimisation of risk to the client. We have extensive expertise in the following areas: information governance, legal and regulatory electronic disclosure, investigations relating to fraud, bribery, corruption, price fixing or other breaches of compliance, disputes and assertion or defence of claims (including warranty, breach of contract and other such claims).

Our discovery and investigation support capabilities help clients to locate, capture and search their data to get to the right information fast, irrespective of data type, volume or location. Our document review tools and forensic data analytics allow clients and their lawyers to conduct early case assessment to determine the merits of an action, review evidence in fraud, corruption, compliance investigations, conduct privilege and relevance reviews and disclose responsive information to opposing parties or regulators. We can also assist with project management, drafting and implementing preservation orders, proving compliance, arguing reasonableness and proportionality, conducting first and second stage document review in any language and create electronic trial bundles.

Our proactive information governance solutions help clients to understand their information and design appropriate programmes to reduce the risks associated with poorly managed information. In providing clients with a robust framework of controls we help to identify and address operational, security, compliance and discovery risks. Together, we implement good practice ahead of technology, account for readiness and maturity in a scalable way and take control of information to turn potential liabilities into assets.

Our team comprises 1500 forensic technology professionals spanning 40 countries globally, with over 90 forensic technology staff in the UK based out of offices in London, Belfast, Birmingham, Leeds and Edinburgh.

Services

- Legal and regulatory electronic disclosure:
 - data capture
 - data analysis
 - data hosting and search
 - production
- Document review

- Investigation support
- Project management
- Electronic trial bundling
- Information Governance/Records Management
- Contract digitisation, governance and lifecycle management

Technology

Data Collection:

- Encase
- Helix
- FTK imager

Decryption:

- Passware

Processing:

- Nuix
- Proprietary technology for processing Chatroom data

OCR:

- ABBYY Recognition Server

Data Hosting Platform:

- Relativity

Voice:

- Nexidia
- Intelligent Voice
- Other proprietary technology

Translation:

- Translation on the fly with proprietary technology

Analytics:

- Relativity Analytics
- PwC eDiscovery Module

8.1.78 QuisLex

Julie Maeir	
julie.maeir@quislex.com +44 (0) 20 3709 2675	
15 Old Bailey, London, EC4M 7EF	
www.quislex.com	
<p><u>Company Description</u></p> <p>QuisLex is an award-winning legal services provider specializing in executing complex document review projects for FTSE 100 and Fortune 500 companies, as well as Magic Circle and Am Law 100 firms throughout the world. Since its founding in 2004, QuisLex has been a pioneer in the provision of managed legal services. With more than 1,200 attorneys, process experts, statisticians and linguists, QuisLex delivers solutions that reduce costs, mitigate risks, and enhance quality. The company's expertise in providing these benefits has been acknowledged by both clients and the legal industry at large, including being recognized by Chambers & Partners as a Band 1 legal outsourcing provider, <i>The New York Law Journal</i> as a top managed document review provider, the <i>Financial Times</i> as a member of its Intelligent Business Top 35, and the <i>IACCM</i> as its "Outstanding Service Provider" for contract management solutions.</p> <p>To date, QuisLex has reviewed more than four billion pages, created privilege logs running into tens of thousands of entries and worked on matters before most major jurisdictions and regulatory agencies worldwide. QuisLex is the partner of choice for many of the world's leading law firms. The company's clients trust it with complex, highly visible bet-the company matters, such as global regulatory investigations in the financial services industry or decisive patent litigations in the technology industry. It also has significant experience in competition/antitrust matters and FCPA/anti-bribery investigations.</p> <p>QuisLex has assisted numerous clients in responding timely and efficiently to high-profile, high-stakes investigations by the Financial Conduct Authority, Serious Fraud Office and Office of Fair Trading. It has also assisted in regulatory and internal investigations throughout the EU and before the European Commission, as well as the Securities and Exchange Commission, Department of Justice, Federal Trade Commission, FINRA and OFAC in the US.</p> <p>QuisLex holds the ISO 9001:2015 certification for its patented Legal Quality Management System and the ISO/IEC 27001:2013 certification for its Information Security Management System. QuisLex is both SSAE 16 (formerly SAS 70 Type II) and HIPPA compliant.</p>	
<p><u>Vendor Offerings</u></p> <p>The company's litigation services focus on managed document review services, which include complete end-to-end project management and quality control, and seamlessly integrate with outside counsel. QuisLex helps clients to prepare for the first CMC and compile defensible and proportionate disclosure strategies, as well as accurate cost budgets. QuisLex also prepares privilege logs, performs redactions for privilege, trade secrets and confidentiality and have vast experience with reviews involving multiple languages, including French, German, Italian, Spanish and Mandarin.</p> <p>Many clients involve QuisLex early in a matter to perform services that some might not traditionally associate with a document review provider. While document review companies may routinely review the documents provided to them, a key aspect of QuisLex's value-add is to proactively identify efficiencies for their clients, which allows them to streamline the process and review fewer documents where possible.</p>	

This can include validating search terms and suggesting changes, as well as using statistically valid methodologies for culling document sets, or creating matter-specific strategies to optimize review.

Recognizing the increasing role of technology in document review and the need to continually improve efficiency, QuisLex has established itself as a pioneer in the application of techniques from the fields of information retrieval and statistics to document review. We have and will continue to be at the forefront of using tools such as predictive coding, email threading, metadata analysis, clustering, and hash value comparison, among others, to winnow down the total universe of potentially responsive documents and identify the most relevant documents to review first.

Post review, clients rely on QuisLex to leverage the expertise gained during the review (knowledge of the documents, custodians, important issues, and key facts) to assist law firms with activities such as preparing for depositions. This allows law firms to focus on the substantive aspects of the matter, while QuisLex can perform the more labour intensive but critical activities such as searching for, analysing, or summarising specific factual content. Having recently been immersed in the document population, QuisLex attorneys are well-positioned to leverage the company's search and analytics expertise to perform these activities, and as permanent employees, they remain available despite the common start and stop nature of review and post review activities.

The company's execution and delivery is further enhanced by the involvement of a dedicated Quality Team comprised of Six Sigma Master Black Belts, Black Belts and Quality Analysts whose sole function in the company is to monitor and improve the quality of the work product delivered. This team serves as an independent check on every project and contributes significantly to their industry leadership. The company's Six Sigma rigour and the expertise of their Quality Team allow them to execute projects on shorter time frames and with a higher degree of quality and budgetary certainty.

QuisLex also utilizes a highly specialized Legal Technology Group comprised of search specialists, linguists and statisticians that test, refine and validate search results, use statistically valid sampling methodologies to test and validate results, and create efficient iterative feedback loops to drive quality and efficiency at every stage of the project.

Software Information

While QuisLex does not provide its own document review platform or software, they have experience with all of the major platforms, such as Relativity, Recommind, Kroll OnTrack, Xerox, Documatrix and Ringtail. A key function of its Legal Technology Group is to optimize the capabilities of the client-chosen platform. QuisLex also maintains a team of technologists and programmers who design customized applications (for example, a privilege log processing application) to extend the capabilities of a given review platform that may not provide certain functionality. At all times, QuisLex securely and remotely accesses the review platform, meaning that the data is never hosted by QuisLex but remains hosted by the corporate client, law firm or third party technology vendor.

8.1.79 Relativity

The Relativity Sales Team	
sales@relativity.com +1 312 263 1177 ext. 4 +44 (0) 20 7153 1132	
231 South LaSalle Street, 8th Floor, Chicago, IL 60604 2nd Floor, 6 Broad Street Place, London EC2M 7JH	
https://www.relativity.com	
<p><u>Company Description</u></p> <p>At Relativity, we make software to help users organize data, discover the truth, and act on it. Our e-discovery platform is used by thousands of organizations around the world to manage large volumes of data and quickly identify key issues during litigation, internal investigations, and compliance projects. Relativity has over 180,000 users in 40+ countries from organizations including the U.S. Department of Justice, more than 70 Fortune 100 companies, and 198 of the Am Law 200.</p>	
<p><u>Vendor Offerings</u></p> <p>RelativityOne is an end-to-end, SaaS platform built on Microsoft Azure, servicing every part of the e-disclosure process, from legal hold through production, including Early Case Assessment (ECA) and investigation. It can be used independently or as a hybrid solution with our web-based on-premises product, Relativity. RelativityOne and Relativity enable case teams to handle the largest, most complex projects using flexible, customisable workflows and powerful search and analytics capabilities - all in a highly scalable environment. The Relativity App Hub - comprised of more than 100 applications and integrations - allows users, consultants, and third-party software providers to design, build, and integrate custom applications on the software's open platform, extending its functionality. RelativityOne and Relativity are available via direct license or through a global network of channel partners.</p> <p>Learn how organisations around the globe are using Relativity here.</p> <p>For more information, see the entry for Relativity in the software sub-section following this one.</p>	

8.1.80 Reveal Data Corporation (Ireland)

Fiona Byrne	
fbyrne@revealdata.com +353 (1) 8572882	
96 Upper Drumcondra Road, Drumcondra, Dublin 9, Ireland	
www.revealdatacorp.com	
<p><u>Company Description</u></p> <p>Reveal Data is redefining flexibility in eDiscovery by combining infrastructure, processing, document review, analytics and production into a seamless user experience. Reveal’s review platform, available in both a SaaS environment and on-prem, combines user-informed features into a faster, more nimble review experience, and provides channel partners the ability to scale to their client’s needs faster than any other industry application. Reveal is used by legal service providers and agencies, Fortune 500 companies, government agencies, and financial institutions in more than 40 countries across five continents.</p>	
<p><u>Vendor Offerings</u></p> <p>Reveal offers our software application behind a client’s firewall or in a dedicated hosted environment provided by Reveal. Our flexible licensing model provides our clients global access to their data and technology partnerships with other applications like NexLP, Brainspace, Total Discovery, Nuix and others. By leveraging AWS and an Elasticsearch index Reveal is the fastest, most stable technology of its kind and has surpassed older technologies that are unable to manage the largest databases. With Reveal, clients pay for what they need, there are no user fees, no long-term commitments or upfront costs.</p>	

8.1.82 Ricoh (US)

David Greetham	
dgreetham@ricohforensics.com +1 713 341 1708	
70 Valley Stream Parkway, Malvern, PA 19355 USA	
http://www.ricoh-usa.com	
<p><u>Company Description</u></p> <p>Headquartered in Tokyo, the Ricoh Group operates in approximately 200 countries and regions. Ricoh is committed to empowering the digital workplace of organizations worldwide, while helping individuals work smarter. As a global company known for professionalism, maturity, and scale, Ricoh instils confidence by designing the most effective workflow solutions that improve workplace productivity and expand revenue streams with enhanced security features to meet our customers' needs.</p> <p>Specific to the legal industry, Ricoh's <i>Intelligent eDiscovery</i> services enables organizations to make informed decisions by designing innovative solutions that deliver exceptional data insight and control. Ricoh customers discover critical information at the earliest stage, proactively manage costs and mitigate risk. Ricoh's comprehensive suite of powerful technologies, hosted within our Microsoft® Azure™ cloud environments with enhanced security features, are supported by our trusted, technology-certified Professional Services team, and Ricoh's more than 80-year global history of innovation and refusal to be limited by tradition.</p>	
<p><u>Vendor Offerings</u></p> <ul style="list-style-type: none"> <p>• Digital Forensics Services</p> <p>Ricoh's Digital Forensics Services is driven by our team of forensics experts inside the first private lab in the world to have been accredited by ASCLD/LAB. We use proven procedures, advanced technology and forensically sound tools – including our patented Remlox™ Remote ESI Collection Tool and Remlox™ Cloud – for fast, reliable collection of ESI and a truly defensible and auditable process.</p> <p>• Ricoh Acumen</p> <p>RICOH Acumen provides advanced business analytics that go above and beyond the standard reporting features currently available through Relativity out of the box. Designated users will be armed with snapshots and trend reports, along with workspace metrics and statistics and real-time review performance tracking. Using the “global view,” users can report on all of their Relativity projects and project history or drill down to single or selected matters — all with interactive, downloadable graphs and an executive summary of all cases.</p> <p>• Ricoh On Demand</p> <p>RICOH On Demand, powered by Venio Systems, is a user-friendly solution that leverages the cloud for full control over the eDiscovery process. Users can upload their Electronically Stored Information (ESI) for processing, analysis, review and production, utilizing an automated production workflow. And it's all hosted within Ricoh's Microsoft® Azure™ Cloud environment.</p> <p>• Managed Review Services</p> <p>Ricoh's Managed Review Services provides proven expertise, professionalism, and a consistent, fully-vetted approach to outsourced legal document review.</p> 	

Our Review Project Managers and contract attorneys specialize in using advanced technologies to efficiently organize, search and cull down the data to only the most relevant in the collection. Our scalable services and flexible pricing models mean Ricoh customers can maximize productivity and manage costs without sacrificing results.

- **Hosted eDiscovery Technology**

Ricoh offers a comprehensive suite of powerful eDiscovery technologies, hosted within the Microsoft® Azure™ environment. Our continual investment of time and resources to proactively seek and assess leading technologies, ensures that our customers have access to the most appropriate tools for their needs, supported by quality processes and the expertise of our trusted Project Management team and eDiscovery experts.

- **Professional Services**

Ricoh's Professional Services team combines certified expertise with tenured experience and a culture of service excellence. We work closely with our customers to fully understand their unique strengths and challenges, and ensure they get the right solution to achieve their business goals, reduce costs and mitigate risk. With innovative thinking, we support legal teams to gain exceptional data insight and control.

8.1.83 Servient

Ben Hammerton, Head of Sales, Servient UK & Europe	
bhammerton@servient.com 0203 350 1398 / 07711 234 413	
48 Chancery Lane, London, WC2A 1JF	
www.servient.co.uk	
<p><u>Company Description</u></p> <p>Servient are a pioneer of machine learning and cloud-based eDiscovery services. The solution is architected for the cloud and developed on the same modern technologies that power the largest web companies in the world. Easy to use and learn, Servient provides savings on the first and every case.</p> <p>Servient allows the client to control as much of the eDiscovery process as they would like. This includes processing, production, creating and managing review teams, running an ECA process and more. Some rely on Servient to help on every step of the way, and others handle it all internally.</p> <p>Servient provides these sophisticated technologies with a new pricing model that is reflective of the modern architecture utilised. No more up-front processing fees, no more user licenses that fluctuate throughout the matter and make budgeting difficult, and no more fees associated with analytics and predictive coding.</p> <p>Put simply, Servient provides robust, scalable, budgetable, and cost-efficient eDiscovery.</p> <p>Key Points</p> <ul style="list-style-type: none"> • Founded in 2003, with offices in UK, USA, and India. • Servient are mainly known for their Continuous Active Machine Learning technology and workflow, which was first created in 2008 and underpins the whole system. • Servient is designed and built for the Cloud and is flexible and customisable depending on the organisational needs. • Servient is provided as: <ul style="list-style-type: none"> ↳ SaaS (software-as-a-service) – on a matter by matter basis. ↳ Managed or Subscription Service – manage multiple cases, on a monthly or annual plan <p>The System</p> <ul style="list-style-type: none"> • <u>Self-Processing Application</u> Allowing you to process as much data as is needed (not just limited to smaller volumes) • <u>Early Case Assessment Application</u> Explore the dataset, run lists of search terms and prepare data for review, prior to sending the data into the review phase • <u>Document Review Application</u> A fully featured, easy to use document review application. Search functionality included: 	

- **Standard** – Comprehensive Search and Analytics functionality: including keywords, phrases, date range, format, file type, custodian, boolean and more)
- **Advanced** – Technology Assisted Review (TAR/Predictive Coding) incorporating Continuous Active Learning, Conceptual Clustering, content-based Email Threading etc (included in the base price)
- **Matter & User Management Module**
Control who gets access and to what level of the case, add or subtract users from a case, create cases on the fly and deactivate them when they complete.
- **Reporting (QC/QA)**
Multiple dashboards and metrics that show the speed, throughput, and accuracy of a review.
- **Production Module**
Users can create a template once and re-use it many times. Productions can be run Natively, in TIFF or PDF – with no extraneous charges for tiffing, branding, or stamping.

Key Differentiators

- **Self-Service** – especially processing, allowing legal teams to effectively run matters themselves without needing to rely on support from a vendor which will waste time and create service bottlenecks
- **Customisable** – allowing true flexibility, the platform can be configurable to specific requirements in terms of screen layouts, user preferences, etc.
- **Modern Charging Structure** – a simple, budgetable monthly data hosting charge, without up-front costs and other variable charges like Monthly User Fees or Analytics
- **Machine Learning** – Servient provides a sophisticated Continuous Active machine learning technology and workflows. Servient gets the user to the critical and relevant information quickly.

Vendor Offerings

The Servient application is wholly owned by Servient, developed with technologies that power the largest web companies in the world. The system provides a simple and intuitive interface that allows easy management of the various stages in the EDRM.

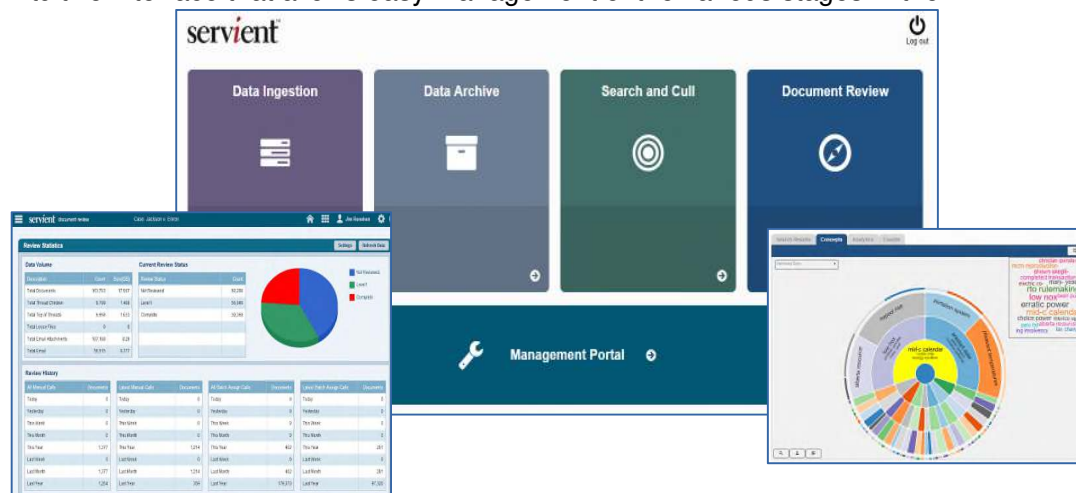

8.1.84 Sky Discovery

Martin Flavell (Director)	
mflavell@skydiscovery.co.uk +44 (0) 207 562 8999 +44 (0) 7486 444303	
Level 17, Dashwood House, 69 Old Broad Street, London, EC2M 1QS	
www.skydiscovery.co.uk	
<p><u>Company Description</u></p> <p>Sky Discovery is a privately owned eDiscovery consultancy business with offices in the UK and Australia, specialising in group litigation, construction litigation and multi-party complex litigation projects. We offer premium project management and consulting expertise by a team of highly experience eDiscovery experts. Services include data collection, processing, Early Case Assessment and document review utilising advanced analytics features and workflows.</p> <p>These services can be provided in a fully packaged managed service which includes the implementation and maintenance of the software and infrastructure. Sky Discovery has implemented a number of managed service contracts with top tier global law firms and sees this as the main area of growth for 2019.</p> <p>Our key focus is to assist legal teams with document review, applying technology effectively to gain maximum efficiency during the review processes and reducing overall litigation costs.</p> <p>As a Relativity Premium Hosting Partner, we offer the full suite of Relativity products and latest features hosted out of our data centres in London and Sydney. Sky Discovery has 7 RCA certified consultants and a number of consultants also hold specialised Relativity certifications include Infrastructure Specialists and Analytics Specialists.</p> <p>By utilising one software solution throughout the project lifecycle, from collection and processing to review and production, Sky Discovery reduces the total review time required, while also minimising the risk of data errors that occur when using multiple software products.</p> <p>Our philosophy is simple, we want to provide the best technology at a price that is truly accessible for all clients, and offer market leading service and expertise that delivers exceptional value.</p>	
<p><u>Vendor Offerings</u></p> <p>Sky Discovery offers a consultative approach to eDisclosure projects and acts as an extension to a firm's in house team. Sky Discovery utilises Relativity as its go to market solution to perform a range of services.</p> <p>Relativity ECA – utilising Relativity 9.6 and the visual dynamic dashboards, our simplified ECA offering allows legal teams to access the data early prior to review so they can make informed culling decisions early, resulting in a richer review set and reducing review costs.</p> <p>Relativity Review – Sky Discovery consultants work with legal teams on litigation projects, information governance activities, regulatory requests and internal investigations, ensuring the technology is applied effectively and providing high end consultancy & project management support.</p> <p>Relativity Analytics - Utilising the full suite of Relativity 9.6 analytics tools, from the basics of email threading and near-duplication, to more advanced TAR and</p>	

predictive coding technologies and workflows, we help clients reduce large datasets to manageable review levels.

Relativity Productions – Sky assists firms with their production requirements using the software’s capabilities blended with years of experience and taking advantage of Relativity’s dashboards and widgets to QC/QA staged data to minimise risk producing privileged documents to the opposing party.

eDisclosure Task & Project Management Software – SkyNav is a web-based collaborative project and task management tool designed to manage all aspects of eDiscovery projects throughout the lifecycle of a litigation. With an intuitive user interface, tasks can be set up and assigned to the team in minutes using built-in templates which are designed to enforce consistency. Communication, time recording, and billing stats can all be recorded within the system. Dashboard reports showing the productivity of the team as well as financial information provides a real time overview of capacity and allows for resourcing decisions to be made quickly and easily.

Automated Hyperlinking Tools - HyperlinQ is an automated hyperlinking tool for Relativity, designed to automatically hyperlink documents referred to in pleadings, witness statements, chronologies and trial bundles. The app will identify document ID’s in the source Word document by recognising document numbering patterns. Documents will either be directly linked to Relativity or be downloaded as an offline copy.

Specialist areas:

Construction Litigation – The variations tables application makes review of complex construction matters manageable in an efficient manner, linking variation requests and site instruction with all related document in the document set.

Group Litigation – This all-in-one automated solution reduces the administrative burden of matters with 1000’s of claimants by integrating a number of smart technologies.

Complex, non-standard data conversion: Not all data can be processed using standard tools. Our team of technical experts and IT specialist can unravel the most complex data set and provide them in a reviewable format.

8.1.85 Smith & Williamson LLP

John Holden	
john.holden@smith.williamson.co.uk 020 7131 8128	
25 Moorgate London EC2R 6AY	
www.smith.williamson.co.uk	
<p><u>Company Description</u></p> <p>Smith & Williamson was founded in Glasgow in 1881 and has, for many years, combined an independent firm of accountants with an investment management and private banking house. Our business spans 12 principal offices and 1,500 staff located across the UK and Ireland with a turnover of approximately £212 million to April 2013. We provide audit & accountancy, forensic services, tax and financial advisory services to corporates, owner-managed businesses, professional practices and private clients.</p> <p>At Smith & Williamson, our prime aim is to help clients achieve their financial ambitions, both corporate and personal, focusing on wealth creation, wealth management and wealth preservation. This unique approach singles us out from our peers and larger competitors, being the only UK financial services firm to combine a top 10 accountancy practice (Accountancy Age 2014) with an investment management and private banking house.</p>	
<p><u>Vendor Offerings</u></p> <p>Forensic technology</p> <p>Our forensic technology team provides a scalable and technically focused solution to issues surrounding the recovery, retention, investigation and presentation of electronic data, both in investigations and during the disclosure process.</p> <p>Our team</p> <p>With over 40 years' combined experience, our team consists of former police officers, IT professionals and lecturers who are not only technically adept, but commercially minded ensuring minimal disruption to a client's business. We can assist those less experienced to gain the maximum benefit from the technology and suggest appropriate ways to maintain proportionality.</p> <p>Investigations</p> <p>Working together with our forensic investigations team, we investigate both criminal and civil cases and can:</p> <ul style="list-style-type: none"> • secure electronic data using overt or covert techniques • review servers with minimal disruption to networks • identify and recover deleted and hidden data from all forms of electronic media • provide clear, non-technical reports on our findings. <p>e-disclosure</p> <p>We offer a complete e-disclosure solution that:</p> <ul style="list-style-type: none"> • consults, collects and prepares documents for electronic review • reduces the cost of e-disclosure through flexible charging structures 	

- saves time and money through more cost-effective planning
- simplifies even the most complex e-disclosure exercise through advanced analytics
- delivers cost efficiency to clients
- allows our clients to regain control of the case.

At the heart of our e-disclosure solution is IPRO Enterprise - featuring Early Case Assessment, web-based review including computer assisted review, near duplicate analysis, concept clustering and high speed processing tools. With these tools, clients can choose to manage the e-disclosure process themselves or our multi-disciplined team is on hand to guide them through any stage of the process if required. By working as part of the client team, we give the insight and assistance needed to ensure a smooth e-disclosure exercise every time.

8.1.86 Special Counsel

<p>Matt Franklin Vice President, UK Solutions</p>	
<p>+44 (0)207 634 0272</p>	
<p>Millennium Bridge House, 2 Lambeth Hill, London EC4V 4BG</p>	
<p>www.specialcounsel.com www.d4discovery.com</p>	
<p><u>Company Description</u></p> <p>Special Counsel D4 is a leading provider of managed data, discovery and review services to law firms and corporations. As one of the first providers to offer an eDiscovery Managed Services solution, the company continues to lead the field in innovation and was the first Relativity Partner to offer RelativityOne in the UK. Overall Special Counsel D4 has been a Relativity Orange Level Best in Service partner for 9 consecutive years.</p> <p>Special Counsel D4 provides technology and review solutions for end-to-end EDRM support. Our data intelligence group provides a consultative experience for matters both large and small. Our global forensics team assists in information governance, preservation, and collection exercises across all jurisdictions. Our full technology suite is available across state-of-the-art data centres and global operations throughout the US, China and the UK while the Managed Review team are widely commended for the quality of their work product and the way in which they proactively collaborate with the client case management team. Depth of staff, experience and innovative technology allow the company to provide first-class performance worldwide.</p>	
<p><u>Vendor Offerings</u></p> <ul style="list-style-type: none"> • eDiscovery/eDisclosure Services • Internal and FCPA Investigations • RelativityOne Subscriptions • Relativity One Hosting • Managed Services • Litigation Support Consulting • Computer Forensics • Data Collections/Mobile Device Collections • Rapid High Volume Processing • Early Case Assessment • Advanced Analytics/Technology Assisted Review • Managed Review and Legal Staffing • Multilingual Reviewers • Machine Translation • Paper Discovery • Legal Copy and Scanning 	

- Deposition Services
- Expert Witness Testimony

3rd Party Software and Solutions Offerings

- Relativity (US and China Data Centres)
- RelativityOne (UK and US)
- Ipro eCapture
- Ipro Eclipse (Managed Service and US Hosting)
- Brainspace
- Nuix
- Veritas
- Systran
- Office 365 Integration
- LexisNexis Law PreDiscovery
- LexisNexis Concordance
- X1 Social Discovery
- Zapproved-Legal Hold Pro
- Cellebrite
- FTK
- enCase

8.1.87 Swiss FTS (Switzerland)

Mattias Aggeler	
mattias.aggeler@swiss-fts.com +41 43 266 78 50	
Sägereistrasse 25, 8152 Glattbrugg, Switzerland	
https://www.swiss-fts.com	
<p><u>Company Description</u></p> <p>Swiss FTS was founded in 2010 in Zurich, and is an independent and provider of Litigation technology and IT forensic services with offices in Zurich, Lausanne and Singapore.</p> <p>As a specialist in IT forensics, electronic discovery (eDiscovery) and information governance, Swiss FTS has the technology and requisite expertise to tackle some of the most challenging data protection and legal problems a company can face. With its many years of experience and its proven expertise, Swiss FTS supports its customers in areas such as fraud, corruption, data theft, sabotage, insider trading investigations, compliance and many others – always with precision, transparency and the utmost efficiency.</p> <p>Swiss FTS is one of the leading corporate investigation firms in Switzerland and operates an ISO 27001-certified data centre in Switzerland and in Singapore for the hosting of sensitive data.</p>	
<p><u>Vendor Offerings</u></p> <p>Swiss FTS offers full-service solutions to all IT Forensics challenges that a major company might face.</p> <p>We are well-equipped and prepared to tackle some of the most challenging data and legal-related problems a company can face. We have extensive experience helping our clients solve problems related to:</p> <ul style="list-style-type: none"> • Fraud • Anti-Trust Regulation Breaches • Arbitration and litigation • Corruption • Employee Misconduct • Anti-Money-Laundering Investigations • Insider Trading Investigations • Insolvency • Compliance • Data Theft • Intellectual Property Theft • Sabotage 	

See overleaf for software information and Certification

Software Information and Certificates



8.1.88 SFTS Engineering (Switzerland)

Mattias Aggeler	
+41 43 266 78 50 mattias.aggeler@swiss-fts.com	
Europa-Strasse 19, 8152 Glattbrugg, Switzerland	
https://www.swiss-fts.com	
<p><u>Company Description</u></p> <p>SFTS Engineering’s goal is to turn our team’s extensive industry knowledge into a set of applications which can be used to improve the efficiency and accuracy of work performed on IT Forensics projects.</p> <p>Our team consists of eDiscovery and IT Forensics experts who have worked on numerous projects for a wide variety of clients. The applications that SFTS Engineering develops are primarily created to solve issues and fill in feature gaps that have been discovered by our team while working on live projects.</p> <p>We don’t just develop applications; we use the tools we create daily to make our tasks easier and our work more reliable. SFTS Engineering is taking this knowledge sharing process a step further by enabling the entire IT Forensics industry to benefit from our experience.</p>	
<p><u>Vendor Offerings</u></p> <p>Illuminate (Relativity add-on):</p> <p>This application extends the feature set of Relativity’s document review and production capabilities. Key features include:</p> <ul style="list-style-type: none"> • In-line document highlighting and commenting • One-click navigation to relevant sections in a document • Advanced summary features showing relevant text and associated comments • Detailed production cover sheets with document highlights and comments • The ability to produce only the relevant sections of documents <p>Penumbra (Relativity add-on):</p> <p>This Relativity add-on streamlines the redaction process when reviewing documents within Relativity. Key features include:</p> <ul style="list-style-type: none"> • Automatic redaction of word-sets • Redaction propagation • Easy management of multiple color-coded redaction sets <p>Transfer Vault:</p> <p>Transfer Vault is a robust stand-alone file transfer tool which can be used internally or with clients. It is designed to be user-friendly, and has built-in automatic encryption and auditing features to securely setup the 2-way communication of sensitive data between secure locations.</p> <p>Custom Development:</p> <p>If you have a problem that our suite of applications cannot solve, SFTS Engineering can develop a customized solution to perfectly meet your requirements. Our application developers are also experienced experts in eDiscovery and IT Forensics, which enables us to better understand your situation and to work alongside your team to create the most effective solution.</p>	

8.1.89 The Oliver Group

Dean M. Felicetti, Partner, VP Sales & Marketing	
dfelicetti@the-olivergroup.com +44 (0) 20 7786 0490	
US = +1 (860) 599 9760	
29 Wilson St, London, EC2M 2SJ 595 Greenhaven Road, Pawcatuck, CT 06379 US	
http://www.the-olivergroup.com	
<p><u>Company Description</u></p> <p>The Oliver Group (TOG), founded in 1997, provides data forensic and media restoration e-discovery services to corporations, litigation support providers, and law firms.</p> <p>TOG is a proven, reliable partner with extensive experience that includes some of the world's most publicized corporate legal actions of the last decade. Our North American headquarters are located in Connecticut and our European Union headquarters are located in London.</p> <p>What We Do</p> <p>TOG helps clients navigate the early stages of the e-discovery process through service offerings that include:</p> <ul style="list-style-type: none"> • Data Acquisition & Forensic Analysis. • Media Restoration & Conversion. • Data Preservation & Remediation. • Data Filtering, Culling and Searching. • Litigation & Compliance Readiness Assessments. • Consulting & Project Management. 	
<p><u>Vendor Offerings</u></p> <ul style="list-style-type: none"> • Data Acquisition & Forensic Analysis – onsite or remote • Media Restoration & Email Conversion – via Native process e.g.: GroupWise to .pst • Data Preservation & Remediation One to one copy, • Data Filtering, Culling and Searching • Data Migration e.g.: Exchange to Office 365 from backup tapes • Legacy System Decommissioning • Litigation & Compliance Readiness Assessments • Consulting & Project Management <p>We use industry standard tools such as Encase, FTK, Cellebrite, etc. as well as our own fully defensible developed in house software.</p>	

8.1.90 TransPerfect Legal Solutions

Charles Lilwall, Account Executive	
clilwall@transperfect.com +44 (0) 20 7061 2039	
Aldgate House, 33 Aldgate High Street, London, EC3N 1AH	
www.transperfectlegal.com	
<p><u>Company Description</u></p> <p>TransPerfect Legal Solutions (TLS) empowers legal professionals to leverage AI, analytics and multi-language technology across e-discovery, forensic consulting, due diligence, privacy, managed review and staffing projects. TLS delivers software and service solutions to every Am Law 200 and Global 100 firm, and the majority of Fortune 500 corporate legal departments.</p> <p>Founded in 1992, TLS has a worldwide presence with over 100 offices and a global team of legal experts. TLS’ consultative approach is supported by an extensive network of resources with proven success in solutions engineering, problem solving, and forging a seamless partnership that clients regularly trust and rely on.</p> <p>TLS customizes service offerings to support the scale, urgency, and scope of each project. Whether your business requires specialized solutions to cull and focus data for discovery in multiple languages, protect against a potential data breach or automate clause comparison in a due diligence, We Know How.</p>	
<p><u>Services Offered by TLS</u></p> <p><u>Forensic Technology & Consulting</u></p> <p>TLS resources and experience allow us to efficiently collect and analyze electronic data from virtually any type of storage device or media. Our solutions are available on-site, in one of our laboratories, or through remote-kit equipment shipped to client locations anywhere in the world. With extensive knowledge of privacy and state secrecy laws, TLS is equipped to deploy on-site culling, filtering, and review. From early data assessment and rapid deployment, to secure evidence storage and expert witness services, we provide a cost-effective forensic and discovery workflow for any circumstance.</p> <p><u>E-Discovery Processing</u></p> <p>TLS provides comprehensive ESI solutions by utilizing cutting edge hardware and industry-leading applications to process electronic data. Recognizing that raw speed is essential when processing large volumes of ESI, we have invested in an extremely powerful processing environment—ingesting up to 17 TB per day. With over 20 worldwide production centers working around the clock, TLS can quickly turn around large amounts of data in a matter of days. We have the ability to process data in-house or—if needed—to work on-site to convert files for processing. Our skilled ESI specialists will work with you to create a customized e-discovery plan that fits your needs.</p> <p>Our state-of-the-art EDA tools allow the TLS team to:</p> <ul style="list-style-type: none"> • Accelerate early data assessments from weeks to hours • Lower processing costs and increase turnarounds by up to 80% • Process large volumes of data 8-10 times faster • Reduce review workload by up to 90% 	

- Wrap up investigations 10 times faster
- Maximize defensibility and control of e-discovery processes

Data Hosting

As one of the first e-discovery providers to adopt and offer the Relativity platform, TLS has established a reputation as an industry leader in hosting technology. TLS has achieved “Best in Service” for four consecutive years among Relativity Partners, and has been awarded Orange-Level status for our commitment to customer service, technical expertise, and technology knowledge.

TLS has developed a proprietary translation-on-the-fly tool that works directly within the Relativity interface. This machine translation functionality allows instant translation between 30+ different languages. TLS has also built a human translation workflow into Relativity, which can push documents into the TLS human translation pipeline, thereby minimising the client-side administrative overhead of handling translations.

TLS was one of the first adopters of Technology Assisted Review (TAR) methodologies and regularly employs them utilizing the Relativity Assisted Review module and Brainspace.

Document Review

TLS maintains top-of-the-line review centers in most major cities in the US, and internationally as well. These secure facilities seat as many as 50 people and are available to all TLS clients pending schedule availability. With offices in over 90 cities on 6 continents, TLS has an unsurpassed network that ties clients in to vast global resources for review space in virtually any location in the world.

When a review engagement has a multilingual requirement, TLS is the ideal partner to deliver what you need. Whether it’s a managed review in Japanese, an on-site team of 10 in Beijing, or an on-site review of a multilingual document set in New York, TLS has the qualified linguistic resources to handle even the most complex requirements. Hybrid teams of linguists, paralegals, JDs, licensed attorneys, and project managers collaborate to ensure that your multilingual review meets the quality and readiness of any project despite language requirements.

Language Services

With a deep understanding of the stringent regulations of the legal world, we create tailored solutions based on the size, subject matter, multilingual requirements, and price limitations of your case. TLS provides language services such as large-scale multilingual and English document reviews, quick summary translations, and interpreters for depositions—all of which are backed by our certified quality management system and worldwide 24/7 production capabilities.

Court Reporting

The TLS Deposition Support and Court Reporting group was built to provide world-class services and solutions to our clients. To that end, we maintain an elite staff of expert court reporters and case management specialists who are versed in handling complex litigations, specific subject matters, and all types of legal proceedings.

Unlike many agencies that work through intermediaries, TLS corresponds directly with every court reporter we use, allowing us to instantly check availability, relay client requests, and monitor deliveries. Our reporters and production staff are keenly aware of our high expectations for excellence in punctuality, demeanour, accuracy, and speed, both on-site and in final transcript deliveries.

Paper Discovery and Disclosure

TLS reprographic centers are specifically designed to handle the intense physical document needs of litigation. With strategic locations in major markets around the world, TLS's paper discovery and production capabilities include:

- Document Scanning
- Copying and Collating
- Printing (High Volume, Color)
- Binder Preparation
- Large Format Documents
- Trial Demonstratives

8.1.91 TSD Services Ltd (Bulgaria)

Plamen Dobrev , Marketing & Sales Specialist	
sales@tsdservices.com +359 2 870 2036	
Tsarigradsko Chaussee 115A, Fl. 7Sofia, Bulgaria	
www.tsdservices.com	
<p><u>Company Description</u></p>	
<p>TSD Services, Ltd is a medium-sized Bulgarian software company founded in 2007 in Troyan, Bulgaria by CEO German Gachevski. The TSD team is currently consisting of more than 60 dedicated personnel. The company operates in three office locations within Bulgaria – Troyan, Sofia and Plovdiv.</p>	
<p>Since 2013 TSD has immersed into eDiscovery, focusing on custom application development for Relativity® platform. TSD has grown considerable expertise that allowed our RelaTeams to actualize various custom development projects and extensions for the Relativity® Platform.</p>	
<p>As Relativity® Development Partner, TSD has also designed its own suite of Relativity-based applications that address common pain points in managing Relativity® and extends it to solve them.</p>	
<p><u>Vendor Offerings</u></p>	
<p><i>Custom Development for Relativity®</i></p>	
<p>You have a killer idea for a Relativity-based application that can help your organization run the business more efficiently? You are looking for Relativity® Custom Development Partner who can develop an application tailored to your specific e-discovery needs? Our dedicated RelaTeams definitely can help you with projects of any size.</p>	
<p>We have built up extensive expertise with:</p>	
<ul style="list-style-type: none"> • Custom pages (integrated, standalone, or both) • Event handlers • Agents (single- or multi-agent setup) • API calls (RSAPI, REST API) • Direct database calls and access • SQL Scripts • Custom RDOs (Relativity® Dynamic Objects) • Console Buttons • Mass Operations • Programming Saved Searches (create, rename and add/remove conditions)* • Structure Relativity® Applications (Object Rules, Layouts, Views, etc.) • Elasticsearch – we have excellent expertise in Elasticsearch – one of the most important additions to Relativity® 9 • Gravity – an open-source framework for all developers in the Relativity community, that makes the custom development on Relativity much easier and faster. Officially endorsed by Relativity ODA. 	
<p>TSD can help you turn your idea into a time-saving or revenue-generating reality, providing you with a designated RelaTeam who will provision the full lifecycle of the project from the initial design to testing and final implementation.</p>	

Relativity® Applications

We explored our clients' most common challenges in running e-discovery operations, and extended Relativity®, building our own Relativity-based applications to solve their difficulties and make requests a reality. Our current Relativity® integrations are:

- **MaxMessage** - an enhanced messaging system across Relativity®, that builds on the Message of the Day (MotD) feature to neatly enhance communications within Relativity by adding different message targets (an individual user, a group of users, on a workspace or and on a platform instance level), periods, attachments, and the long-awaited message acknowledgment history.
- **MaxBilling** - a Relativity®-based application that automates the billing process experience and streamlines the invoice-to-cash cycle. It allows you to monitor both yours and your client's Relativity data usage and ensure you are billing each client properly. You can generate detailed and easy-to-read PDF or Excel reports with calculated costs from pre-set pricing metrics and custom rates including Case Rollup, Case Flow, Users, Analytics, Processing, Indexes, Custom Tasks. MaxBilling reduces the time and effort you spent on billing, while also minimizing the potential for errors.

Services for Relativity®

- **TSD Development Training for Relativity®** – a course that covers the fundamentals of Relativity® Custom Development. This includes development with Gravity - our open-source development tool for all developers in the Relativity® community to use, contribute to, and improve. The course is designed to start you on a path toward future studies in Relativity® custom development, no matter how much experience or technical knowledge you currently have with the platform. It teaches you how to rapidly create agents, event handlers, custom pages and much more with corresponding business logic. By the end of this 5-day training through both theory and practice sessions, as well as homework assignments, our trainees gain the skills needed to manage and code documents in Relativity®.
- **Compatibility Certification and Warranty for Relativity® Apps** – a tailored solution which provides regular quality assurance testing of your custom Relativity® applications, scripts, or workflows. It represents an annual support and maintenance service, which ensures that your custom Relativity® apps and workflows are compatible with the latest Relativity® release. It will help you achieve an easy and smooth transition from Relativity® on-premises to RelativityOne.

8.1.92 Venio (US)

Charles Lavallée	
clavallee@veniosystems.com +1 301 908 1981	
4031 University Drive, Suite 100, Fairfax Va. 22030	
www.veniosystems.com	
<p><u>Company Description</u></p> <p>Venio Systems is a team of innovators and developers with 30 years of experience in providing eDiscovery solutions. At its core Venio Systems was created to address the industry’s lack of unified eDiscovery solutions. VenioOne, a unified eDiscovery platform and VenioOne OnDemand are designed to provide law firms, corporations and government entities with the ability to manage all phases of discovery and investigations — processing, ECA, analysis, review, and production — from a single software solution. Venio Systems remains at the forefront of innovation with a new direction in our technology providing the most agile and adaptable discovery platform available for today’s global legal requirements. Based in the United States, Venio is currently used at top law firms, the 2 largest government agencies in the US, and by thousands of attorneys & solicitors through our partners in the US, Canada, UK/EU, and Asia. References are available by request.</p>	
<p><u>Vendor Offerings</u></p> <p>Venio Systems provides the unified discovery software platform VenioOne and VenioOne OnDemand. VenioOne manages the full EDRM lifecycle with processing, early case analysis, machine and active learning analytics, review and production. The addition of VenioOne OnDemand to VenioOne enables Venio’s capabilities into a fully automated self-service discovery platform addressing more of today’s discovery challenges.</p> <p>Venio Systems development is an agile process with a bi-weekly release of new updates and enhancements. 24/7 software support, maintenance and training are included. Site consultation, custom development and Software Certification are also available.</p>	

8.1.93 Veritas

	
infogov@veritas.com + 44 0800 279 9810	
350 Brook Drive, Green Park, Reading, Berkshire, RG2 6UH	
www.VERITAS.com	<p>Company Description</p> <p>Veritas enables organizations to harness the power of their information, with solutions designed to serve the world’s largest and most complex heterogeneous environments. Get industry-leading solutions that cover all platforms with backup and recovery, business continuity, software-defined storage, and information governance.</p> <p>From traditional data centers to private, public and hybrid clouds, Veritas helps enterprises protect, identify and manage data regardless of their environment through a comprehensive and innovative product strategy and roadmap.</p> <p>Veritas enables organizations to make informed decisions about all of the information they store. The integrated Information Governance portfolio synthesizes intelligence across unstructured data sources and facilitates action to ensure organizations are best positioned to counter information risk.</p>
<p>Vendor Offerings</p> <p>Veritas Information Governance products and solutions simplify and automate the control of unstructured data. Achieve compliance and limit liability by gaining control of critical business processes including retention, eDiscovery, and risk management. Combined with advisory and assessment services to help with increasing regulatory demands such as the impending European Union (EU) General Data Protection Regulation (GDPR) and FOIA in the USA.</p> <ul style="list-style-type: none"> - Universal Classification. Enforce intelligent retention policies by quickly locating and quantifying valuable and sensitive data. - Risk Analytics. Identify access and permission vulnerabilities before a crisis hits. Discover how Data Insight can help you predict risk. - Integrated Workflow. Cut through timely delays with single-click integration that unifies your analytics, retention and discovery processes. <p>Information Map</p> <p>Information Map provides an immersive visual experience for users to gain insight into your organisation’s unstructured information.</p> <p>Data Insight - Data Classification, File Analysis & Access Controls</p> <p>Data Insight is a file analysis solution that provides the tracking and reporting necessary to deliver organizational accountability for file usage and security.</p> <p>eDiscovery Platform - Respond quickly and easily to legal, regulatory and discovery requests</p> <p>eDiscovery Platform arms investigators with a single solution to streamline regulatory requests and solve challenges across the entire eDiscovery lifecycle. The Veritas eDiscovery Platform brings transparency and control to the electronic discovery process. From collection to production, our workflow speeds time to resolution, improves accuracy and lowers costs. With better insight and less</p>	

complexity, the eDiscovery Platform enables you to focus on strategy and create business value.

Features; Classification, Redaction, Annotation, Transparent Predictive Coding, Audio Processing, Search, & Review, Distributed Architecture and multiple source collectors including O365 and Enterprise Vault products,

[Enterprise Vault and Enterprise Vault.Cloud](#)

Veritas Enterprise Vault helps automate retention management, classification and supervision, while simplifying search and eDiscovery over unstructured data. Veritas Enterprise Vault.cloud provides a SaaS archiving solution for retention and eDiscovery from both cloud and on-premises sources, such as Microsoft Office 365, Microsoft Exchange, SharePoint Server, Lync instant messaging or Skype for Business.

8.1.94 Vound Software (Intella) (US)

Peter Mercer (Founder and CTO)	
Peter.Mercer@vound-software.com +1 612 9451 3819	
1153 Bergen Pkwy #1537-267 Evergreen, CO 80439 USA	
http://www.vound-software.com	
<p><u>Company Description</u></p> <p>Vound is a leading global vendor of technology used for end-to-end forensic search, eDiscovery and early case assessment. Our Intella® range of eDiscovery and digital investigation software is used by over 1500 organisations worldwide including the Big 4, Fortune 500 enterprises and Big Box Retailers, national security agencies, global banks, law firms, and law enforcement for Human Resources, Legal and Compliance matters.</p> <p>Intella’s strength lies in taking large collections of data and allowing users to quickly search and drill down to the most pertinent evidence; minimising the need for experts and significantly cutting the time and costs organisations normally take to carry out investigations, audit requests and eDiscovery.</p> <p>Intella enables even the novice user to quickly find evidence and make an informed decision on their data, and is, therefore, widely recognised as one of the most intuitive and easy to use Early Case Assessment and e-discovery solutions on the market--without the complexity or costs associated with similar products.</p> <p>For more information, visit www.vound-software.com.</p>	
<p><u>Vendor Offerings</u></p> <p>Intella® Product Family</p> <p>Find your evidence fast.</p> <p>Intella delivers powerful process, search and analysis capabilities in an easy-to-use platform for single-user investigations through to multiple-reviewer teams. Intella products are priced starting from Intella PI for single users/ up to 10 GB, for \$99.</p> <p>Intella’s key features are designed to help reviewers and investigators get the job done quickly, simply and cost-effectively. Whether you are a seasoned litigation support professional or lawyer in a small firm, Intella range of products are suited to your needs.</p> <ul style="list-style-type: none"> • Market-leading indexing speeds for faster evidence processing • Enhanced search and analysis capabilities of mobile data collections, forensic images, email, attachments and embedded objects, archives, headers, and metadata • Load file support for all major legal export formats, to include ingestion of existing load file productions • Task and export wizards to create and implement repeatable, template-driven processing steps • Additional file level support for indexing native EnCase images, DD, L01, MacOS, GPT and ISO • Multiple analytic visualizations, including Intella’s unique Cluster Map and Sets View 	

8.1.95 XBundle Ltd

Mark Agombar	 XBUNDLE
marka@xbundle.co.uk +44 (0)207 871 3125	
160 Fleet Street, London EC4A 2DQ	
www.xbundle.co.uk	
<p><u>Company Description</u></p> <p>XBundle – the innovative litigation software suite – was originally designed and developed by Robert Onslow, a leading IP/IT barrister at 8 New Square, with his early pioneering version being created in 2004.</p> <p>XBundle is comprised of two modules:</p> <ul style="list-style-type: none"> • XBundle::Assemble - revolutionising the creation of electronic document bundles; and • XBundle::View - the trial presentation software, which has already had success in the courtroom. <p>At XBundle we are building on Robert’s legacy and continuing to enhance and grow his innovative products which are being used by a Silver Circle law firm, a global Top 10 law firm as well as in other smaller firms and has proved its credentials with use in the Competition Appeals Tribunal. XBundle is a true workhorse for all electronic presentation of evidence requirements.</p>	
<p><u>Vendor Offerings</u></p> <p>See software section for details.</p>	

8.1.96 Yerra Solutions - an Elevate Business (Switzerland)

Josie Johnson	
josie.johnson@yerrasolutions.com +41 61 262 02 23,	
Freie Strasse 11, CH-4051, Basel, Switzerland	
www.yerrasolutions.com	
<p><u>Company Description</u></p> <p>Yerra Solutions is headquartered in Basel, Switzerland and has offices in the UK, US, Singapore, Hong Kong and Poland. The company was founded in 2013 and was acquired by Elevate Services in 2019. Yerra provides consulting and technology-enabled managed services for legal & IP, eDiscovery & investigations and compliance with a focus on large, international organisations in highly-regulated industries. Joining Elevate, a leading law company with over 1,200 employees, expands Yerra’s ability to scale globally and meet the needs of these complex clients.</p> <p>Yerra partners with clients to help them bring eDiscovery in-house, implement technology and streamline processes. Expert consultants help clients define and accomplish a target operating model and managed services teams, that are fully embedded into client operations, execute on every phase of the EDRM. Yerra is especially qualified in the complexities around cross-border data privacy issues and has in-country resources in the most stringent jurisdictions like Switzerland and Singapore. Yerra is also uniquely qualified to handle sensitive eDiscovery issues for financial institutions and does so for some of the largest banks in the world.</p>	
<p><u>Vendor Offerings</u></p> <p>eDisclosure/eDiscovery Consulting</p> <ul style="list-style-type: none"> • Litigation/Investigation Readiness Assessments – Our experts will evaluate current systems and processes, identify gaps and make recommendations on how to best prepare an organisation for inevitable discovery requests due to litigation or regulatory investigation. • Early Case Assessment – Leveraging years of experience, Yerra consultants evaluate a request to produce Electronically Stored Information (ESI) and offer an estimate of the cost and time it will take to fulfil the request. This helps minimise exposure to risk and aids in a decision about settlement. • Reporting and Analysis – With eDisclosure representing a large and ever-growing percentage of legal spend, Yerra offers services to identify costs and provide expert analysis of how to handle future cases more efficiently. <p>eDisclosure/eDiscovery Managed Services</p> <ul style="list-style-type: none"> • Case Management – Yerra team members are experienced in project managing cases from start to finish. Working in tandem with the client’s legal, IT and discovery teams, we handle every request for information to ensure the timely delivery of defensible results. • Preservation and Collection – Yerra employs forensic and eDisclosure specialists on behalf of our clients who are uniquely skilled in handling the preservation and collection of data from sources spread around the world. We focus on high-quality chain-of-custody and process documentation to manage the risk involved in moving data across borders. • Review and Redaction – Yerra employs legal professionals on behalf of our clients that represent various level of experience. These teams review documents pertaining to all types of matters, from the mundane to highly- 	

Chapter 8 – Supplier & Software Details

sensitive “bet the company” litigation and investigations. We adhere to strict confidentiality and quality control protocols to produce quality work efficiently and defensibly.

8.1.97 ZyLAB UK Ltd (Dutch)

Lennert Hoogvliet (VP Sales EMEA/APAC)	
Lennert.hoogvliet@zylab.com +31 (0)20 691 9550	
Laarderhoogtweg 25, 1101EB Amsterdam	
www.zylab.com	
<p><u>Company Description</u></p> <p>ZyLAB is an innovative and strategic leader in eDiscovery technologies. Over the past 35 years, ZyLAB has been working closely with law firms, corporations and governments to deal with eDiscovery, answering regulatory requests, internal investigations, audits and handling public records requests.</p> <p>The ZyLAB software is developed to meet the specific requirements for such applications, and is available in on-premises, SaaS and Azure deployments.</p> <p>To learn more, please visit www.zylab.com.</p> <p>Gartner recognizes ZyLAB as “leader” in the latest Magic Quadrant for eDiscovery Software and ranks ZyLAB #1 for complete EDRM eDiscovery in its most recent “Critical Capabilities for E-Discovery Software” report. On Gartner’s review platform Peer Insights, users rate ZyLAB software with five stars out of five.</p> <p>For more information, visit: www.zylab.com</p>	
<p><u>Vendor Offerings</u></p> <p><u>ZyLAB ONE eDiscovery</u></p> <p>ZyLAB ONE eDiscovery uses Artificial Intelligence and Data Science to limit the disruptive effect and costs of litigation, arbitration and regulatory information requests related to anti-trust, competition, fraud, bribery, financial-, environmental-, healthcare-, and export violations and the subsequent internal investigations or damage claims.</p> <ul style="list-style-type: none"> • ZyLAB’s Direct Collecting makes tremendous time savings to get data ready for early case assessment and (first) pass review. Direct Collection drastically reduces the cost and risks of downloading / uploading data or the shipping around of tapes and hard disks. • ZyLAB’s Deep Processing allows you to automatically reduce your data volumes before you send them on for review, without getting in trouble or being accused of data spoliation. • Using ZyLAB’s Review Accelerators you can minimize the most expensive and time consuming part of the eDiscovery process. • Litigants use ZyLAB’s Early Case Assessment to quickly understand the facts and merits of a case, identify key custodians and recognize critical information so they can develop an effective and realistic litigation strategy. <p><u>ZyLAB eDiscovery as a Service</u></p> <p>For a predictable monthly subscription fee, ZyLAB ONE eDiscovery as a Service provides you with the infrastructure to host and manage your cases, providing you on-demand access to your information as well as tools to collect, upload, process, perform early case assessments, analytics, TAR, review, redact, and produce documents in native TIFF or PDF formats.</p>	

ZyLAB ONE eDiscovery is a great way to experience our technology, perform a proof-of-concept for a full-scale deployment, or manage a smaller or ad-hoc eDiscovery case. ZyLAB offers three levels of services:

- eDiscovery as a Service in a managed services model.
- eDiscovery as a Service, '24/7 ready DIY'
- eDiscovery as a Service within your Microsoft Azure.

BENEFITS

- You can start immediately, no need to install on-premises software or hardware.
- Lower starting costs and low (case-based) monthly bills instead of large capital investments.
- Scale as you need and as you go.
- Always the latest releases and the most advanced technology available.
- Easy to use and deploy in-house and with 3rd party service providers.
- The best professional services available for additional customizations and assistance.

8.1.98 Zylpha

David Chapman, Head of Marketing	
d.chapman@zylpha.com 01962 658881	
Suite 4, Poles Copse, Poles Lane, Winchester, Hampshire, SO21 2DZ	
www.zylpha.com	
<p><u>Company Description</u></p> <p>MAKING LAWYERS' LIVES EASIER THROUGH THE SMARTER USE OF TECHNOLOGY</p> <p>That's what excites us and why we get out of bed in the morning.</p> <p>As former lawyers, paralegals and IT professionals within major law firms we know what lawyers do well. It also puts us in a unique position to understand the problems that face lawyers daily, with technical expertise to overcome those issues.</p> <p>We know that lawyers are great at 'the lawyer-y bit' and we believe that lawyers should be freed from administrative tasks that stop them from doing what they are good at.</p> <p>In our experience many of these tasks can be simplified using technology, and that's what we have been doing for over 15 years; writing software that gives lawyers more time to do the stuff they spent years training for.</p>	
<p><u>Vendor Offerings</u></p> <ul style="list-style-type: none"> • Electronic document (Court) bundling software with integrations into many case/document management systems • Electronic signature integrations for iManage, SolCase & Visualfiles • Many integrations for Visualfiles including MoJ portal, HM Land Registry, Smartsearch, PayPal and more • SolCase and Visualfiles development and optimisation 	

8.2 Software

This Section details the software used by various companies. As there are firms that use third party products, at the end of each section is a box showing which company owns/supplies the product and a second line show which firms use the software as part of their offering to the marketplace.

Owned/Supplied by :	
Used by :	

8.2.1 AccessData Software Suite

FTK: Zero in on relevant evidence quickly, conduct faster searches and dramatically increase analysis speed with FTK®, the purpose-built solution that interoperates with mobile device and e-discovery technology. Powerful and proven, FTK processes and indexes data upfront, eliminating wasted time waiting for searches to execute. No matter how many different data sources you’re dealing with or the amount of data you have to cull through, FTK gets you there quicker and better than anything else.

AD Lab: Divide and conquer with AD Lab. This proven tool helps you power through massive data sets, handle various data types and run multiple cases at the same time, all within a collaborative, scalable environment. AD Lab uniquely enables distributed processing, allowing investigators to utilize additional hardware to dramatically increase their case processing and resolution speed.

Quin-C: This pioneering software solution from AccessData is changing the way digital investigations happen, empowering investigators, legal teams and forensics labs of all sizes with ground-breaking tools and transforming their work environments. Quin-C speeds data access, processing and analysis, and offers a highly customizable, widget-based User Interface for more accurate, advanced investigations in less time. It’s simple, visual and powerful, with flexible out-of-the-box configurations to fit the unique needs and challenges of any type of investigation or case work. Quin-C integrates seamlessly with all other AccessData products or is available as a stand-alone.

AD eDiscovery: A single, fully integrated platform for forensically sound preservation/litigation hold, search, collection, processing, data assessment and complete legal review, AD eDiscovery gives teams a repeatable, defensible process for managing e-discovery that will hold up in court.

Summation: Summation® is the only all-inclusive, web-based legal review platform that provides teams with a single tool for managing all post-collection stages of e-discovery. Powered by trusted FTK® processing technology, Summation combines processing, review and case organization into a single product for the most cost-effective, accelerated e-discovery possible. And because Summation utilizes a single shared, forensically secure backend database, data never has to move throughout the e-discovery process, reducing risk of data loss and spoliation.

AD Enterprise: Today’s digital forensics teams face many challenges in a world filled with an overwhelming amount of data. From multiple office locations, to massive employee pools and remote workers, AD Enterprise provides deep visibility into data to investigate employee wrongdoing and to facilitate regulatory and legal requirements so you can respond quickly, remotely and covertly while maintaining chain of custody. Whether investigating personnel, fact checking a whistleblower’s claims, or investigating government inquiries, AD Enterprise facilitates focused forensic investigation and post-breach analysis, without interruption to business operations.

Owned/Supplied by :	Access Data
Used by :	Access Data, A&M, FRA, Grant Thornton, Stroz Friedberg.

8.2.2 Anexsys Review Tool Kit (RTK) Suite

RTK.ExcelRedact

RTK.ExcelRedact takes Excel documents of any shape and size and renders them in an interactive webpage within Relativity, allowing users to make redactions quickly and easily without missing important data. Imaging Excel spreadsheets for redactions can result in unexpected pagination and formatting, and often removes plenty of the useful content present in an Excel workbook; redacting Excels offline makes it easy to miss hidden data that should be considered for redaction. This application allows users to consider and redact all data in an Excel document, including non-cellular data such as macros, named ranges, and more. RTK.ExcelRedact is provided as a Relativity Application in a RAP file and can be installed directly through the front end of Relativity.

The screenshot shows the RTK.ExcelRedact interface. At the top, there are tabs for 'CONTROLS', 'METADATA', and 'SAVE'. Below these are various redaction tools: 'Select', 'Remove', 'Black', 'White', 'Text', and 'Replace'. A 'REDACTED' button is also visible. To the right, there are options to 'Redact Entire Worksheet' and 'Redact All Cells In Worksheet'. The main area displays an Excel spreadsheet with columns A through F and rows 1 through 19. The spreadsheet contains various data points, including company names, dates, and numerical values. Some cells are redacted with black boxes, and others are highlighted with red borders. The data table is as follows:

	A	B	C	D	E	F
1						
2		[Company Name]				
3		Customer Profitability Analysis				
4		[Date]				
5						
6		[Redacted]				
7			[Redacted]	[Segment Name]	[Segment Name]	Overall
8		Customer Activity:				
9		[Redacted]		8		21
10		Number of customers added	2	4	4	10
11		[Redacted]	-1			-5
12		[Redacted]	6			26
13						
14		Profitability Analysis:				
15		Revenue per segment				
16		Weighting				
17						
18		Cost of sales:				
19		Operating expenses	1,000,000	1,000,000	1,000,000	3,000,000

RTK.Loadfile

RTK.Loadfile was designed by the consultants at Anexsys to solve everyday challenges encountered when dealing with document loadfiles. RTK.Loadfile automates common loadfile tasks including comparison of a loadfile against a Relativity workspace and splitting loadfiles for faster ingestion, or for complying with requirements of a production or disclosure specification.

RTK.Message

Standard exports from social media and messaging applications are often in a format including XML formats. There’s also often lots of ‘noise’ such as entries and exits in a Bloomberg chat room, as well as irrelevant data such as data outside the relevant date range from a social media profile export.

RTK.Message has a built-in processing engine which supports a variety of message formats and Anexsys have created a message parser framework which allows new sources, for which a parser doesn’t already exist, to be rapidly created.

RTK.Message populates a staging area for messages, which harnesses the power of the Relativity UI. By using widgets and dashboards, reviewers and administrators can quickly filter the message data to remove irrelevant content, and promote potentially relevant data to the main document review.

During the publishing stage, RTK.Message can create one document per message, or per conversation, but can also consolidate messages into groups such as a daily, weekly, or monthly digest of messages. The output is a modern, easy-to-review HTML document.

#	Application	Date	From	To	Message Body	Class	Type
				Jane Jones (Jane) jane.jones@anexsys.com, Jim Bloggs (Jim) jim.bloggs@anexsys.com, Peter Booth (Peter) peter.booth@anexsys.com			
12	Bloomberg	01/04/2015 12:20	Jim Bloggs	John Smith (John) john.smith@anexsys.com, Jane Jones (Jane) jane.jones@anexsys.com, Sam Howard (Sam) sam.howard@anexsys.com, Peter Booth (Peter) peter.booth@anexsys.com	What's your meeting about?	Chat	Message
13	Bloomberg	01/04/2015 12:16	Peter Booth	John Smith (John) john.smith@anexsys.com, Jane Jones (Jane) jane.jones@anexsys.com, Sam Howard (Sam) sam.howard@anexsys.com, Jim Bloggs (Jim) jim.bloggs@anexsys.com	I'll see you there	Chat	Message
14	Bloomberg	01/04/2015 12:16	John Smith	Jane Jones (Jane) jane.jones@anexsys.com, Sam Howard (Sam) sam.howard@anexsys.com, Jim Bloggs (Jim) jim.bloggs@anexsys.com, Peter Booth (Peter)	Excellent	Chat	Message

DocumentFolio

DocumentFolio quickly collates documents into a searchable, elegant, branded application enabling end-users to view, search and print electronic documents. DocumentFolio offers complete versatility to create electronic bibles (eBibles), transaction volumes, bid submissions and more, via an easy to use desktop application. With the ability to customise the interface to match your requirements and brand, DocumentFolio delivers electronic content to users securely and conveniently. eBibles can be created from a standard legal index, leaving little requirement for time-consuming and often inaccurate data entry. Developed in-house by Anexsys' software developers in collaboration with a leading international law firm, DocumentFolio is a next generation eBible solution.

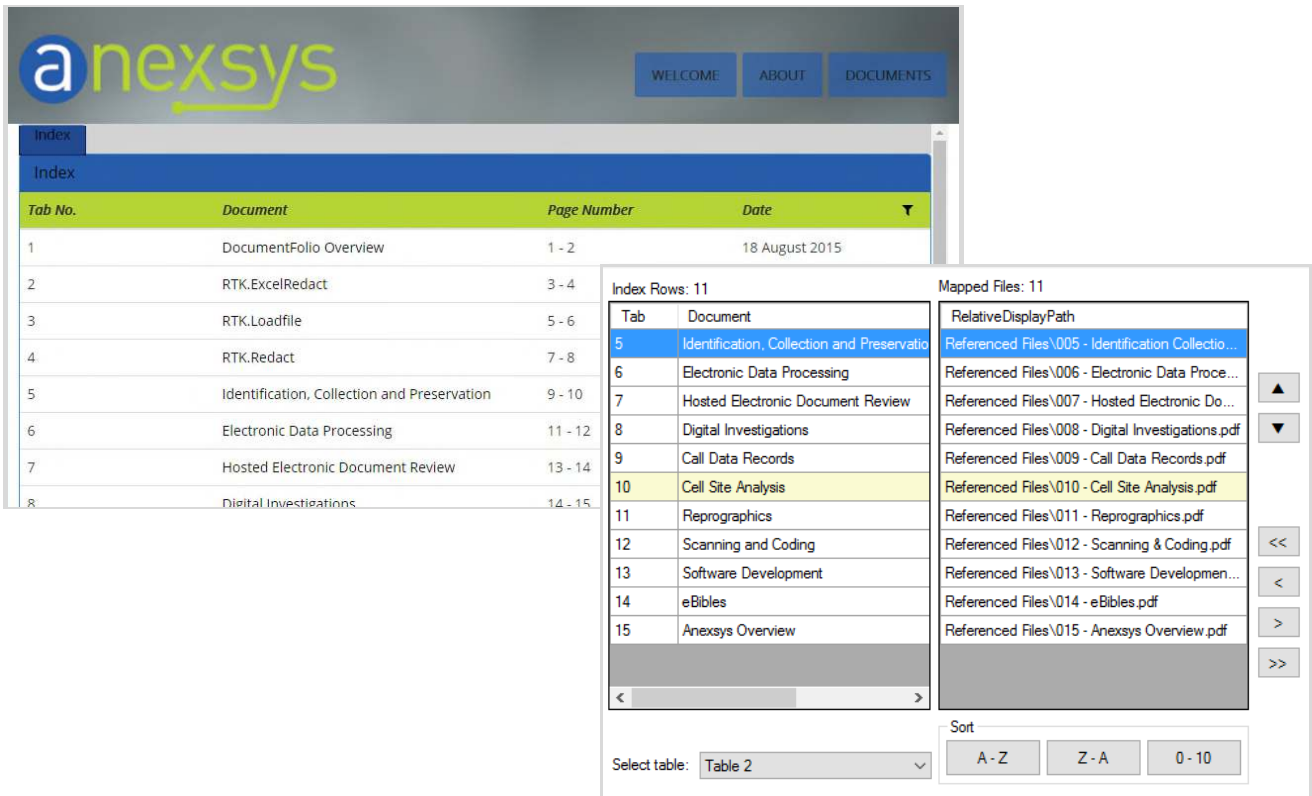

Owned/Supplied by :	Anexsys
Used by :	Anexsys

Chapter 8 – Supplier & Software Details

8.2.3 Aon Software Suite

STANDARD eDISCOVERY SERVICES	PREMIUM SERVICES
Deduplication	Standard eDiscovery Services +
DeNISTing	ECA with First Glance
Data Filtering	Email Threading
Data Processing	Near Duplication
Hosting in Relativity	Concept Searching/Clustering
Productions (tiff, bates, brand)	Keyword Expansion
Free User Licenses/Month	Predictive Coding
Standard PM Support	Privilege Analytics
Dedicated PM Team	Stroz Extract

How Do We Charge?

ALL YOU CAN EAT	PAY AS YOU GO
Annual Fixed Fee	Tiered Discounted per GB Rates Or, per Custodian rates Standard or Premium Services Available
Volume-based	
All-inclusive Services	
Two other <u>free</u> Stroz Friedberg Pilot Service Offerings (e.g. Cyber Security, Compliance, IP Analysis, Due Diligence)	

Security Features

Stroz Friedberg's Managed Services & Litigation Repository employs a robust security architecture which includes the following:

- Full law enforcement-level chain of custody on all devices and data
- Data stored with SSAE16: SOC1/SOC2, ISO/IEC 27001:2005, ISO 22301, and/or FINMA certification(s).
- Internal information security protocols
- Regular security assessments under HIPAA, PCI DSS standards, and/or NIST 800-53.
- Security certifications:
 - Security Essentials Plus Certification (UK)
 - Subject matter experts with CISSP, CIPP, CEH, GIAC, GPEN, and CISM

Owned/Supplied by :	Aon
Used by :	Aon

8.2.4 ayfie Software Suite

ayfie Inspector for Relativity®

ayfie serves legal teams around the world with innovative Artificial Intelligence (AI) products that streamline document review processes and maximize efficiency for reviewers.

ayfie Inspector is a powerful text analytics suite that lets customers find crucial information within their content. It goes beyond putting together patterns of words or similar names. It puts persons, locations, organizations and time into relation and connects dots that might have been missed otherwise. It presents its findings in a user-friendly interface with data visualizations that make multi-layered data relationships easier to see. It provides a modern way to cull down the massive data sets of today’s litigations.

ayfie Inspector deploys easily in the leading technology stack of Relativity®. Its linguistics-based feature engineering is a critical differentiation which injects structure and domain specific entity knowledge to vast amounts of text-based content for rapid filtering. Leveraging aided intelligence, ayfie immediately identifies redundant information through familiar workflows including email threading for inclusive materials and accurate near-dupe analysis. With its predictive search module, ayfie adds intuitive data querying by sample documents to explore large volumes of documents with ease. The ability to use ayfie Inspector in “Fact Finding” drives immediate results.

ayfie Inspector for Relativity® revolutionizes productivity and accuracy for document review with state-of-the-art Continuous Active Learning (CAL) workflows. The enhancements of CAL powered by SenticAI™ provide a new level of precision and ease in supervised machine learning workflows for the Relativity® ecosystem. The Inspector for Relativity® analytics suite is based on best of breed technology and leverages a combination of linguistic and powerful machine learning products. It enables a “revolutionary speed-to-relevance”, informing case strategy, while saving time and money.



ayfie Locator for knowledge discovery

Finding the right knowledge is critical to success. The ayfie Locator indexing and search software puts an end to restrictive data silos, increases productivity and helps companies gain greater IT agility without losing control. It enables employees to find information they didn't know existed. ayfie Locator pulls all your enterprise data into a Universal Index™ and makes your content accessible anytime, anywhere, across teams.

While Locator helps teams find files and their respective locations — access right management remains securely in place to protect content and maintain control over distribution. ayfie Locator’s pre-built connectors make setup easy.

ayfie Locator for knowledge discovery turns your data into knowledge resources — examples lawyers can use to work more effectively. The greatest asset of your company is your “know-how”. ayfie Locator normalizes and structures data from 450 file types, allowing you to use them. It provides fast and intelligent views into the most relevant information by automatically identifying meaning across multiple data sources. It connects users to the knowledge they need.

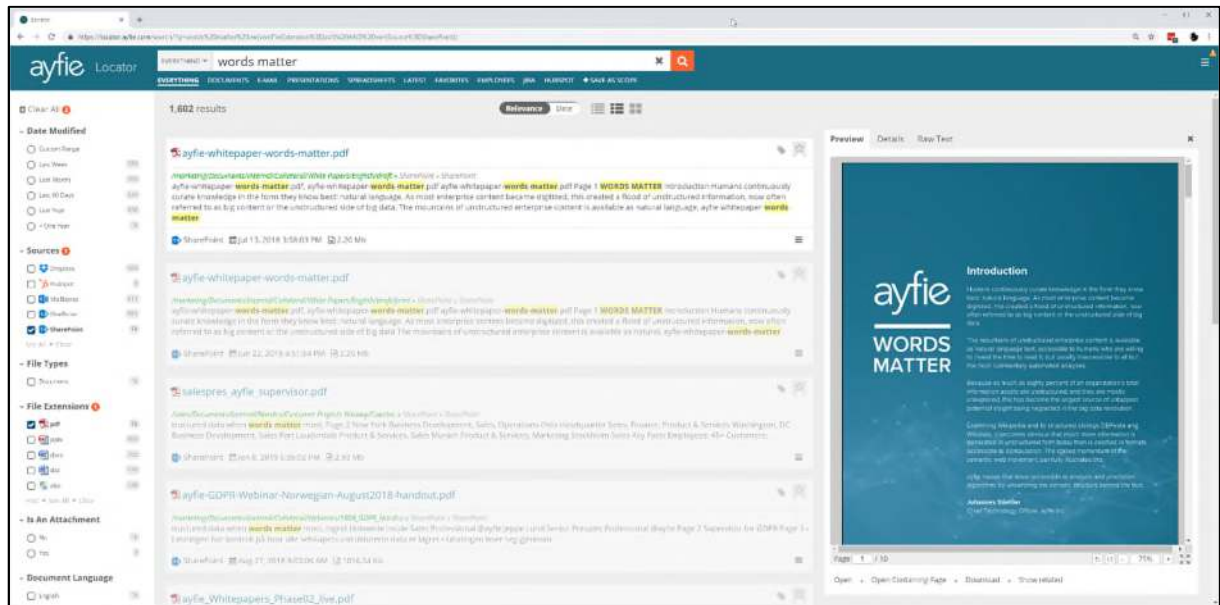

ayfie offers a free personalized demo for both products that can be requested on the following site: ayfie.ie/demo

Owned/Supplied by :	ayfie
Used by :	ayfie

8.2.5 Bundledocs

Bundledocs is the ultimate document bundling software and provides law firms and legal departments with everything they need to get the job done.

With powerful technology underlying our functionality, Bundledocs helps alleviate common pain points such as:

- Table of Content Creation
- Pagination and Late Inserts
- Document Manipulation
- Secure Sharing and Collaboration
- OCR
- Redaction and Annotations

Collaborative working is easily accommodated so you can work with colleagues in different offices, securely share bundles with clients, or even collaborate with any third party. You even have the ability to make annotations public or private which is ideal when working with others.

Bundledocs has an open API allowing us to seamlessly integrate with your system. We already integrate with leading systems including: iManage, NetDocuments, Tikit TFB, Timeslice, Actionstep, Worldox etc.

Our cloud first technology provides users with a secure, stable platform for the creation of any size bundle – large or small. Our unique approach means that resources are added when needed meaning you don't have to worry about slow PC's or systems stalling and crashing.

The best bit? Bundledocs is software you'll love using. It's incredibly simple and easy to use. No need for long laborious training sessions. No need to wait for install and setups. Just pick it up and go!

Owned/Supplied by :	Bundledocs
Used by :	iManage, NetDocuments, Tikit TFB, Timeslice, Actionstep, Worldox

8.2.6 CaseLines (from Netmaster Solutions)

CaseLines is the market leading service for the preparation of legal bundles and electronic presentation in the courtroom. Our systems hold over 250,000 cases, with over 65 million pages of evidence held securely in the cloud. Compared with CMS bundling tools, CaseLines is less complex to implement and manage, is preferred by Counsel, court staff and judges, and delivers increased savings.

CaseLines is a secure web-based service that allows legal teams to collaborate on any legal content – mediation or trial bundles, deal bibles, contract packs etc. CaseLines gives the team online access to a secure shared workspace, without the hassle or cost of setting up a separate data room, which can be accessed from anywhere in the world. It saves the trouble and cost of regularly re-issuing pdf bundles every time the contents change or re-printing hard copy sets. Key features include:

- Hosting of trial bundles and evidence documents with remote online access
- Automatic indexing and hyperlinking
- Dynamic hyperlinking of opening/closing submissions to bundle documents, or from witness statements to exhibits
- Notes ‘stick’ to the correct page in the bundle even when pages are added or moved around. Notes can be private or shared within the trial team
- One-click streaming of audio and video evidence or recordings of the hearing
- Instant on-demand virtual hearings and video conferencing, with the ability to store a recording in the case file
- Multiple bundles, with access managed at the sub-bundle level, allowing mini-bundles to be created for juries, expert witnesses etc.
- Automatic duplicate detection using AI fuzzy matching

API's are available for integration to case management systems to facilitate easy loading of evidence bundles, and also to court management systems which allows a CaseLines evidence bundle to be generated automatically whenever an application is made through the court eFiling systems.

CaseLines provides a simple interface for access to cases.

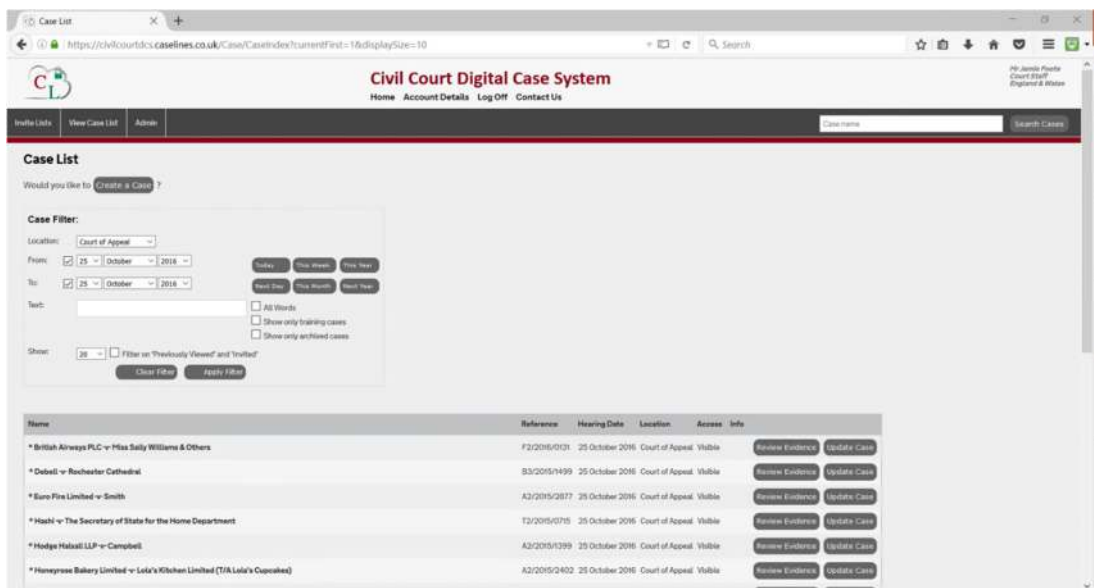

Chapter 8 – Supplier & Software Details

CaseLines is used by civil litigators, public law lawyers for child protection and adoption cases and by private and public prosecutors, including a wide range of criminal cases. Over 1,000 judges in the UK have been trained to use CaseLines.

The CaseLines courtroom review interface provides tools designed to simplify courtroom presentation, designed with the help of judges and tested every day in hundreds of cases across the UK:

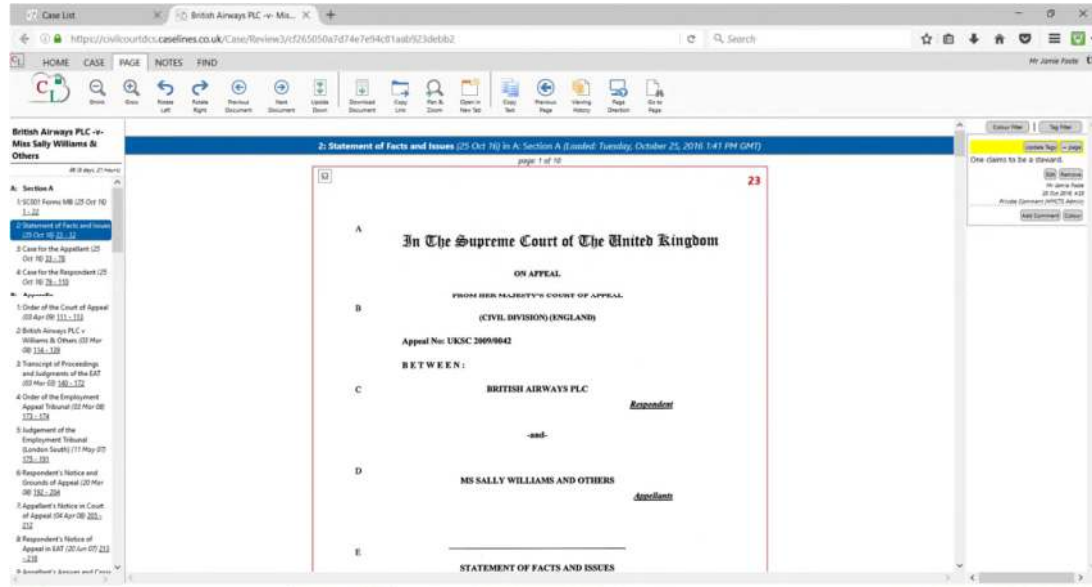

CaseLines is the only solution which allows video evidence (interviews, CCTV, body worn camera) to be indexed and hyperlinked within the evidence bundle, then streamed to the court with a single click. Video evidence can be tabbed and noted and the court taken to a key segment with a single click.

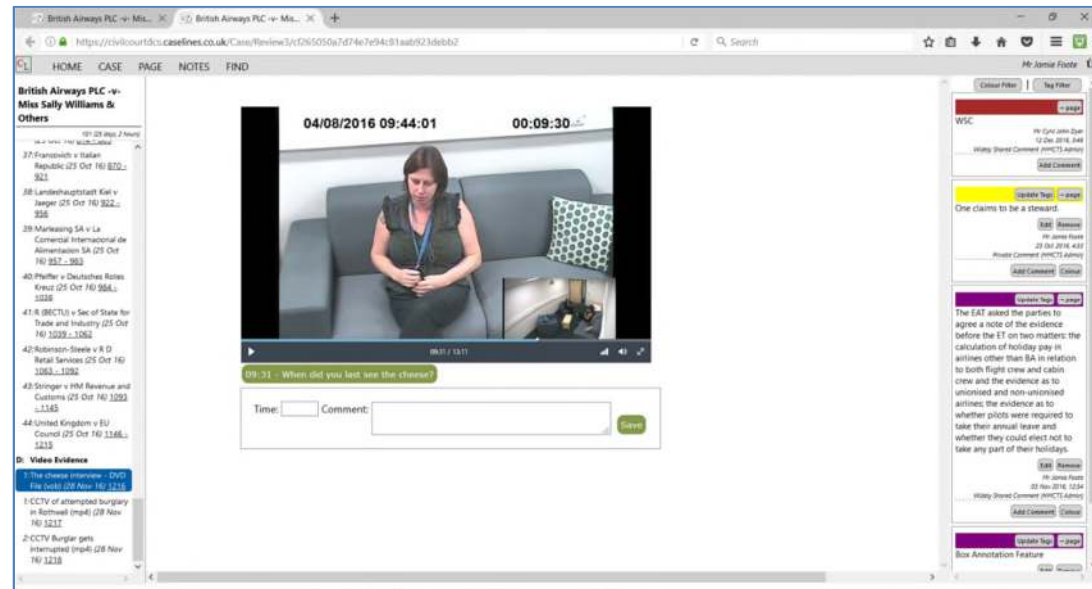

Supplied by :	Netmaster Solutions
Used by :	Baker & Mackenzie, Norton Rose Fulbright, Eversheds Sutherland, Taylor Wessing, King & Wood Malletsons, DLA Piper, K&L Gates, Crown Prosecution Service, West London Family Courts, DIFC Courts, Abu Dhabi Global Market Courts, Manchester City Council, Ealing and Brent Councils, Orbis Public Law, BT plc, Irwin Mitchell, South Africa Civil Justice System, COMESA Court of Justice

8.2.7 Case Logistix

Case Logistix is a robust document-review and production platform offering you a quick, simple, and accurate way to review electronically stored information (ESI) and traditional "paper" throughout the discovery process.

Case Logistix makes it easy to meet the challenges of eDiscovery.

- Intuitive Design: Case Logistix looks and feels like other common office tools.
- Native Review: Case Logistix lets you review documents in native formats, maintaining key formatting and metadata.
- Flexibility: You can customize Case Logistix to meet the need of the case – rather than forcing the case to adjust to the application.
- Scalability: Built on a Microsoft® SQL database foundation, Case Logistix can scale from single-server/desktop configurations to robust multi-server solutions storing many millions of documents.
- Security: Control security at folder, document, data, and functional levels, ensuring that users see only what they need to see and do only what they need to do.
- Global Capabilities: Case Logistix is Unicode-capable, allowing you to find and review foreign language documents and localize to particular languages.

Owned/Supplied by :	Thomson Reuters
Used by :	Anexsys, Legastat.

8.2.8 CasePoint

Casepoint's flagship technology offering is Casepoint eDiscovery as a SaaS, on-premise, and hybrid-mode model. Casepoint eDiscovery is a full-spectrum eDiscovery solution that features state-of-the-art tools including:

- **Cloud Collections** - Casepoint can directly collect cloud-based data with its revolutionary, disruption-free process. Example cloud systems Casepoint can pull from include:
 - Office 365 and Microsoft OneDrive | Gmail and Google Drive | Dropbox and Box
- **Data Processing** - Casepoint has a powerful built-in data processing engine that can process over 600+ file types. Clients can upload and process their own data using our web interface and desktop tool.
- **ECA / Culling** - Casepoint offers a wide variety of culling tools. In addition to deduplication and de-NISTing, timeline and advanced filtering, Casepoint makes available our full range of analytics and AI-based tools to support client's culling needs
- **Review & Advanced Analytics** - Casepoint is a full strength review platform that offers a robust set of review, redaction, tagging, advanced search, and data visualization and analytics tools.
- **Artificial Intelligence** - Casepoint offers built-in artificial intelligence and analytics that are the most robust in the industry, with advanced tools for TAR 1.0 and TAR 2.0.
 - Casepoint also offers a first of its kind artificial intelligence based automated case evaluation system called CaseAssist. CaseAssist proactively identifies and alerts case teams of potential hot documents, helpful search terms, important dates, and likely "junk" documents. Instead of laboriously running complex search terms or reviewing predefined batches of documents, CaseAssist begins presenting potentially relevant documents to attorneys and investigators when they log into Casepoint on the fly.
- **Productions** - Casepoint offers highly customizable production features and functions built directly into the platform allowing detailed level specifications and features
- **Organization and User Management** - robust organization, user, and administrative management features and functions to manage eDiscovery across the enterprise

With Casepoint eDiscovery, legal teams can complete discovery projects faster, at a lower cost, and with greater accuracy using a single, integrated, easy-to-use tool. All customers get the complete package – there are no features to turn on or pay for later and no user fees. Our SaaS clients pay for hosting and service. Our on premise offering comes in a variety of structures, but we can also provide the software to run on your hardware as well as provide the software and hardware to run behind your firewall. We also offer mixed-mode (hybrid) solutions between your on premise deployment and our SaaS cloud.

Casepoint Platform is an innovative technology platform that law firms and legal departments can use to integrate a full range of enterprise applications, documents, legal data, and workflows, into a single flexible platform. Casepoint eDiscovery is also an infinitely scalable private cloud-based software-as-a-service (SaaS) solution capable of handling millions of documents, multiple terabytes of data, thousands of legal matters, and unlimited numbers of users.

Chapter 8 – Supplier & Software Details

Pricing has been structured for maximum transparency, without upsells or user fees.

Casepoint Security

Casepoint security is focused on data security, integrity, and reliability at the company, datacenter, and application/database level. At the company level, Casepoint maintains the following:

- ISO 27001:2013 Certification (Information Security Management Systems)
- ISO 9001:2015 Certification(Quality Management Systems)
- SOC 2 Type II Accreditation
- Casepoint is also in the process of obtaining our FedRAMP certification and SSAE 18 attestation – expected Q2 2019.

At the datacenter level, Casepoint has chosen facilities that meet the highest security requirements and credentials. Data centers are fully replicated for business continuity. Casepoint's private cloud environment resides in secure data centers that have achieved:

- ISO 27001:2013 Certification
- SOC 1 Type II Accreditation
- SOC 2 Type II Accreditation
- Energy Star and LEED Certification
- PCI DSS Certification
- HIPAA Compliance

At the application & database level, Casepoint utilizes role-based security. Casepoint uses military grade encryption utilizing AES 256 bit encryption. Data is encrypted both in transit and at rest.

Owned/Supplied by :	Casepoint
Used by :	Casepoint

8.2.9 Catalyst

Powerful Search

Insight provides the most powerful field and text search in the market. It is lightning fast, even for complex field and text searches against tens or hundreds of millions of documents. (We've tested searches involving over a million characters.) But Insight search goes well beyond Boolean constructs.

Use Faceted Search to analyze field values as you drill into your results. Or Tracked Search to analyze key words in anticipation of a Meet and Confer. Or PowerSearch to run a thousand searches with the click of a mouse.

Visual Analytics

Not only did we improve the standard results page with flexible columns, previews and the ability to stack three fields in a column, but we also provided visual insights into your data.

Change to a chart view against any of your fields or several at the same time. Switch to a timeline view and drill into the dates. Track email communications between one and many or focus on two key witnesses with email and a timeline view.

Review Workflow

Organize review teams and carry out review easily and efficiently with Catalyst's unique review workflow module. Set up review stages to fit your plan, dragging them where you want them. Set up users and workflow rules to determine where the documents go next.

Let the reviewers have at it. They get documents dynamically, as they need them. You follow their progress through the review dashboard or create reports to track progress, productivity and tagging patterns.

Paging and Highlights

For review teams, the key metric is documents per hour. We designed Insight to provide the fastest paging in the industry, even with large text files and thousands of highlights. You click Save & Next, and your next document is instantly before you, no matter how big it is. We've used every trick in the programmer's book to improve productivity.

Unlike most other products, we don't limit the number of highlights you can show. Insight can display hundreds of thousands of highlights on massive text files in seconds. No more compromising on your review because of product limitations.

Processing and Productions

Rather than wait for your vendor to act, take control of the process yourself. Insight is automated from processing and loading right on through to production. Do it yourself at any time, nights, weekends or holidays.

Unlike most vendors, we've spent years developing a fully automated system. Load data through your custom, secure FTP site and watch as Insight automatically picks up the delivery and processes it according to your specifications. Since 2008, we have run more than 125,000 automated loads and produced hundreds of millions of documents.

User Control

Although we host Insight securely in our private data centers, you can run it just like a local appliance. Set up a new site based on an existing model, manage users, set up new fields, choose redaction labels, folder structures, search fields, lookups and much more.

Give different rights to different user groups, from outside reviewers, to your internal team and even outside experts. The system supports private fields, folders, and searches so you can use it with joint defence groups or even opposing parties.

Chapter 8 – Supplier & Software Details

Owned/Supplied by :	Catalyst Repository Systems
Used by :	Catalyst Repository Systems

8.2.10 CloudNine

CloudNine provides four software offerings for clients:

1. CloudNine eDiscovery Platform
2. Preservation and Collection from CloudNine
3. Legal Hold Notifications from CloudNine
4. Outpost for Relativity from CloudNine

CloudNine eDiscovery Platform

What is the CloudNine eDiscovery Platform?

The CloudNine eDiscovery Platform (CloudNine), the company's proprietary eDiscovery automation software, is a secure, web-accessible, SaaS-delivered offering that allows clients to immediately upload, review, and produce electronic documents for litigation, investigations, and audits. Built with speed, simplicity, and security in mind, CloudNine users experience the benefits of:

- **Speed:** With an all-in-one eDiscovery platform users can load data, start reviewing, and produce in less than 5 minutes.
- **Simplicity:** CloudNine was built to be intuitive enough for the non-technical user but have all the functionality power users crave.
- **Security:** Housed in our own protected cloud. We use a TIA-Tier 4 data facility to ensure that data never leaves our hands

How do customers use CloudNine?

CloudNine allows users to start their electronic discovery with three easy steps:

1. Users Upload data to CloudNine's private network for automated processing.

CloudNine allows users do-it-yourself uploading of data to our secure online repository while automatically converting documents to a usable format for review. We offer cost effective cloud-based eDiscovery software to process and review large volumes of data, reducing the expense of traditional processing, loading, and hosting.

2. Automated processing "automatically" converts documents for review.

CloudNine is an intuitive platform with multiple viewing options, giving users the ability to review their way. Create review sets for multiple reviewers. Add users and data fields as needed. Set user rights to control access to functions, fields, and documents. With a comprehensive search engine, users can even get highlighting images.

3. Users begin searching and filtering documents in minutes and produce with flexibility.

CloudNine makes producing responsive data easy, generates production and privilege logs, and eliminates the need for additional processing after export. Image, native and text files can be exported, with the images Bates numbered, custom-branded, and converted to single or multi-page TIFF or PDF with a load file.

- One real-world example of this process in action is as follows:
- Client registered online (with no contract) and began to upload data immediately.
- Client uploaded 27 GB of PST email files.
- CloudNine processed 300,000 documents (Emails and Attachments).
- CloudNine reduced document set by 61% with deduplication and irrelevant

domain filtering.

- Client with CloudNine accomplished these tasks within 24 hours of registering.

[Click here](#) to learn more about CloudNine's simplified eDiscovery automation.

Preservation and Collection

What is Preservation and Collection from CloudNine?

Delivered as an integrated and automated capability in CloudNine's cloud-based, Software-as-a-Service eDiscovery automation software, Preservation and Collection from CloudNine improves collection workflow by efficiently and comprehensively accelerating legal and IT team ability to detect, identify, locate, and collect ESI in a targeted, comprehensive manner. And once collected through an automated ingestion process, ESI is automatically processed and prepared for analytics and review in support of litigation, investigations, or audits.

How do customers use Preservation and Collection from CloudNine?

Available at no incremental cost as part of the CloudNine eDiscovery Platform, the automated preservation and collection capability is accomplished through an eight-step, wizard-driven selection process that includes:

1. A secure login to the CloudNine eDiscovery Platform
2. The selection of the files and folders to be collected (scanning of local drives or specific folders)
3. The selection of a processing option (host with CloudNine, host with Relativity, build early data analysis report, or automatically create a load file for a third-party eDiscovery platform)
4. The selection of the project for the collected data to be added to (creation of a new project or loading into an existing project)
5. The selection of the time zone for the collection
6. The naming of the collection (custodian, location, etc.)
7. The secure upload of the collection (compression and uploading)
8. The upload confirmation for the completion of processing for analytics and review

Upon completion of the preservation and collection process, users are automatically and immediately ready to begin using the analytics and review capabilities as determined by their processing option selection (CloudNine, Relativity, or Load File for export to additional platforms).

To see a short technology snapshot of this offering in action, [click here](#).

Legal Hold Notifications

What is Legal Hold Notifications from CloudNine?

Legal Hold Notifications from CloudNine empower legal and information professionals by enabling them to quickly and comprehensively develop, send, track, and manage legal hold notices to key custodians with the goal of protecting data integrity for potential or current investigations or litigation.

How do customers use Legal Hold Notifications from CloudNine?

With the defensibility and repeatability exemplified in all CloudNine eDiscovery automation technology, Legal Hold Notifications from CloudNine can be initiated quickly and directly from within CloudNine eDiscovery Platform and managed as part of a guided three step process. This three step process includes:

Step One: Understanding and Managing the Current Legal Hold Landscape

Step Two: Creating Legal Hold Notifications

Step Three: Confirming and Tracking Legal Hold Notifications

[Click here](#) to learn more about Legal Hold Notifications from CloudNine.

Outpost for Relativity

What is Outpost for Relativity from CloudNine?

Outpost for Relativity from CloudNine is CloudNine’s eDiscovery automation integration provides Relativity users with a tool that accelerates the upload, processing, and ingestion of electronically stored information (ESI). This complementary capability allows Relativity users to immediately ingest ESI directly from their desktops and automatically move ESI into Relativity.

How do customers use Outpost for Relativity from CloudNine?

Outpost allows users to automatically move data into existing Relativity platforms or helps users create a new Relativity environment with CloudNine’s hosted Relativity for Outpost. Outpost processing consists of more than thirty advanced processing tasks to ensure data is immediately actionable when automated loading into Relativity is completed. To use Outpost, clients first need to contact CloudNine for a demonstration/overview of Outpost. Upon completion of the demonstration/overview, clients will then have the opportunity to engage with CloudNine to gain access to an Outpost-enabled version of CloudNine.

[Click here](#) to learn more about Outpost for Relativity from CloudNine.

Owned/Supplied by :	CloudNine
Used by :	CloudNine

8.2.11 Concordance FYI

Concordance® e-discovery management software decreases the complexity of managing discovery and allows your team to search, review, organize, produce and share litigation documents - scanned paper, email and other e-discovery - generated during discovery.

Owned/Supplied by :	Cloud Nine
Used by :	IDS-Legal, Legastat.

8.2.12 Consilio Product Suite (Global RPM®)

Document Review in Global RPM® or Relativity®

Global RPM is a secure, web-based document review platform designed and built by Consilio's in-house development team to meet the challenges of complex eDisclosure exercises. Global RPM is hosted in Consilio data centres across the globe to aid compliance with local data privacy restrictions.

The platform supports both small- and large-scale document review exercises and offers a range of features designed to simplify and speed up the review process, such as intuitive, customisable review interfaces and highly efficient workflow-management tools.

Users have the ability to perform simple or complex searches, create tags and folders, apply redactions and comments to documents, and select groups of documents for production. Global RPM allows searching and review of electronic documents in any language.

Using dynamic visuals such as dashboards, timelines and enhanced statistics, review managers can gauge resource requirements, monitor review progress, track reviewer productivity and adjust workflow to meet deadlines.

Consilio offers clients the option to host their matters in kCura's Relativity review platform. As an Orange Best in Service premium hosting partner, Consilio offers the full range of Relativity's suite, including Relativity Analytics. The company has hosted hundreds of matters in Relativity and has over 75 worldwide Relativity Certified Administrators (RCSs), Relativity Review Specialists, Relativity Assisted Review and Analytics Specialists, relativity Experts and Relativity Infrastructure Specialists.

Recently joined with Huron Legal and Proven Legal Technologies, Consilio maintains multiple Best in Service Blue™ data centres in Europe. The combined, Consilio organisation has maintained Best in Service™ status in London every year that the accreditation has been available and longer than any other organisation outside of the United States.

Technology Assisted Review in Global RPM

Advanced analytical technology identifies and groups near-duplicate and conceptually similar documents as well as email threads; concept searching and clustering enable lawyers to prioritise documents for review more efficiently and deploy computer-assisted review techniques in appropriate cases.

Consilio offers clients a fully supported predictive coding solution as a cost- and time-efficient alternative to manual human review. The predictive coding technology, Backstop, allows for the creation and optimisation of multiple predictive coding models concurrently within the same review process. Each predictive model (tag specific) is independent of one another; thus each document will receive a probability score from each predictive model generated. The technology also handles sets of documents in multiple language without the need to create separate workflows. Consilio project managers support clients throughout each stage of the process ensuring that results are understood and optimised.

Enhanced Audio Review in Global RPM

Global RPM fully integrates Nexidia's world-leading, patented phonetic-indexing and search technology to allow the searching and review of audio files such as telephone conversations in the same platform as the rest of the disclosure material. This streamlined one-system approach delivers dramatic improvements in accuracy and the opportunity for significant cost reduction.

Enhanced Chat Review in Global RPM

Consilio's Enhanced Chat solution is fully integrated into Global RPM and overcomes the challenges associated with chat reviews from Bloomberg and other platforms. In addition to keyword searching and date range filtering, the search engine allows for filtering and searching over chat specific fields which enables our clients to focus their review on specific chat participants, companies, participant count, and other fields of interest. Furthermore, dynamic filtering out of the chat "noise" of disclaimers, entry-exit and history events significantly improves the accuracy and efficiency of the review process.

Owned/Supplied by :	Consilio
Used by :	Consilio

8.2.13 Digital Reef (A TransPerfect Company)

TransPerfect's Digital Reef is the only processing and ECA platform that has proven it can process 17 TB in a single day. The processing engine scales across available servers and processing cores to support any size case and is not limited to single server scalability like other tools. Nearly all data types are supported, including mail archives such as Microsoft PST and OST, and Lotus Notes NSF files. In addition, forensic containers such as E01 and L01 files are automatically mounted, deNISTed and processed, without requiring that they are first flattened by hand.

On top of this powerful processing engine, our clients enjoy an intuitive yet powerful ECA interface that allows datasets to be culled quickly and easily. Each client has full access to their case data for Boolean searching, reporting, tagging, and advanced similarity analytics. Analytics offers "find more like this" searching, clustering, and near-duplicate analysis which is included in the ingestion rate. Email Threading is provided using both email metadata and content, depending on the quality of the data. OCR is also built-in so that image-only TIFFs, PDFs, and low content PDFs can be automatically scanned for textual content.

Digital Reef processing and ECA key features:

- Powerful multi-server grid architecture
- Processing tools for litigation support personnel
- Intuitive ECA interface for case team and attorneys
- Email threading viewable and exportable
- Clustering based on advanced similarity analytics
- De-duplication, de-NISTing and near-duplicate detection
- Multi-byte Unicode for support of all foreign languages
- All ECA work product (such as tagging) exportable to review
- Extensive reports, include search breakdowns and email histograms

Interface

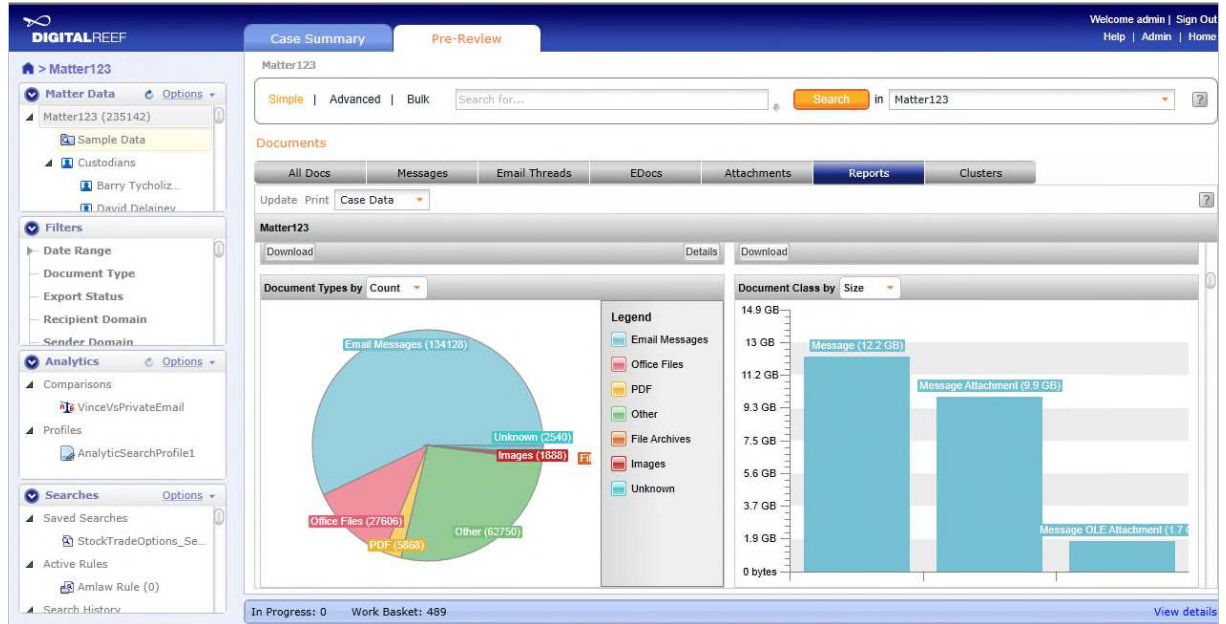

Example Reports

Email Volume Histograms: Email Sent Date and Email Received Date

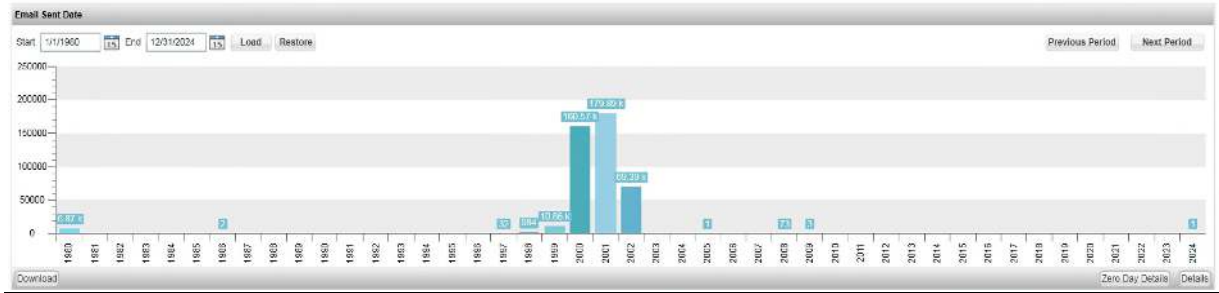

Email Addresses for Sent and Received Email

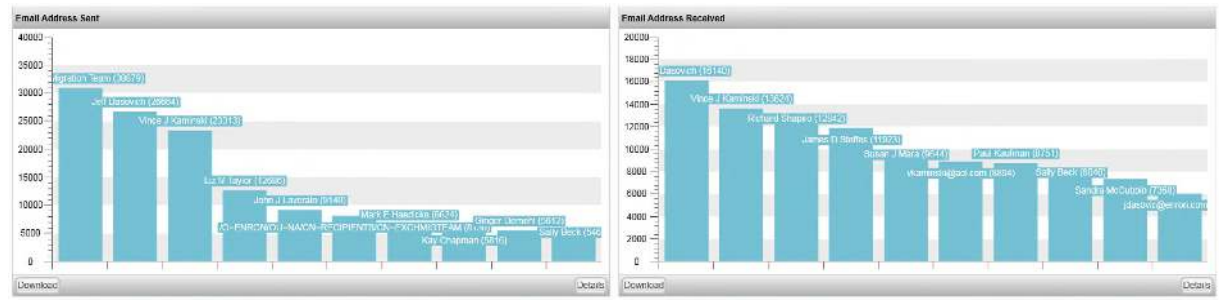

OCR Confidence Level Report

OCR confidence		
Name ▲	Count	Size
0-10	948	48.6 MB
11-20	4	126 KB
21-30	16	923.4 KB
31-40	52	3.5 MB
41-50	43	13.1 MB
51-60	35	7.8 MB
61-70	85	20.3 MB
71-80	109	57.4 MB
81-90	440	48.8 MB
91-100	703	590.6 MB

Download Details

Language Identification Report: Dominant Languages

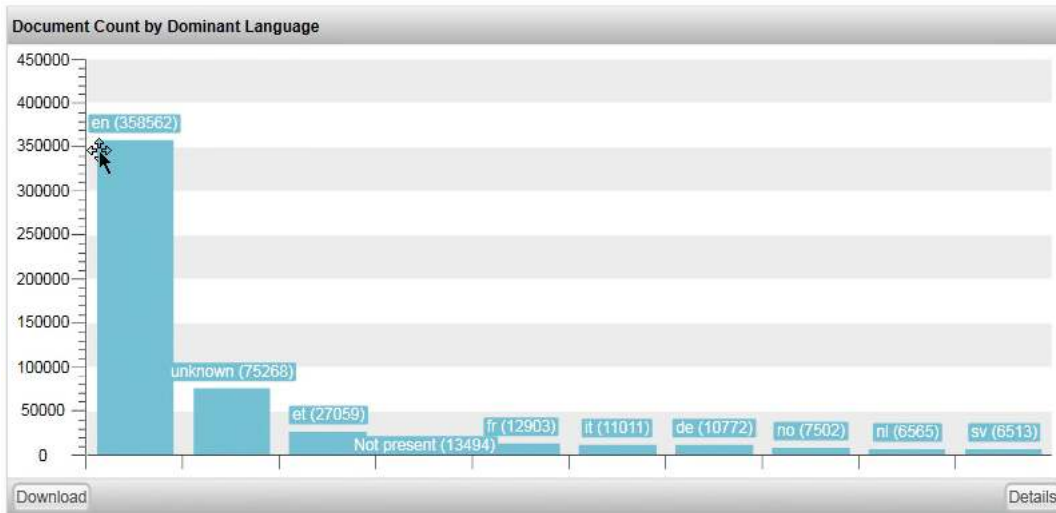

Chapter 8 – Supplier & Software Details

Clustering and More Like This

Search Results

Name	Top Terms	Documents	Tags
More like Re: Real Options in Matter123-2	vince,ect,kaminski,hou,subject,enron,token-email,please,forwarded,can	1653	
More like Re: Real Options in Matter123-3	enron_development,vince,ect,paul,sydney,presentation,july,raymond,kaminski,can	103	
More like Re: Real Options in Matter123-4	enron_development,ect,enron,subject,hou,gas,cairn,doug,please,forwarded	307	
More like Re: Real Options in Matter123-5	options,opon,price,value,spread,real,time,pricing,prices,can	428	1
More like Re: Real Options in Matter123-6	options,real,valuation,group,risk,value,conference,management,energy,business	339	
More like Re: Real Options in Matter123-7	real,time,conference,options,token-email,call,power,please,electric,perspective	43	
More like Re: Real Options in Matter123-8	paul,token-email,vince,work,some,management,message,might,call,other	229	
More like Re: Real Options in Matter123-9	ect,vince,can,hou,kaminski,enron,options,subject,please,houston	152	
More like Re: Real Options in Matter123-10	vince,sandeep,india,enron_development,ect,reminder,subject,houston,kaminski,dpc	26	
Unclaimed List		0	

Doc Number: 1.60.2892 | Tag: | File: | To: | Date: 2000-05-22-15-57 67 | Score: 57

Author: vkamins
Filename: final0524.doc

7 EXOTIC OPTIONS Vincent Kaminski, Stinson Gibner and Krishnarao Pinnamaneni Enron Corp. Exotic options continue to increase in use as a means of controlling exposure to energy prices. One factor contributing to this increased popularity stems from

Doc Number: 1.61.2852 | Tag: | File: | To: | Date: 2000-10-12-15-59 65 | Score: 65

Author: EGS LAN MGR

DIGITAL REEF

Case Summary | **Doc Review**

Matter123 - Searching for ((stock OR trade OR ...)) More like Re: Real Options in Matter...

Simple | Advanced | Bulk | Search for: | Search at Matter123

Search Results

Doc Number	Tag	File	To	Date	Score
1.43.13916			From: Stinson Gibner Subject: Re: Real Options	2002-04-04-16:29	57
1.43.13990			From: Paul Smith Subject: Re: Real Options	2001-04-03-10:00	57

From: Stinson Gibner
Subject: Re: Real Options

Paul, Krishna and I are thinking that you may be able to book this type of option as a call option on power. If you would like to discuss further, let's set up a time when we can call you. -Stinson- Forwarded by Stinson

From: Paul Smith
Subject: Re: Real Options

Stinson: Krishna, Paul Q, Raymond Y and I will call 5:30pm Houston time Thursday afternoon to discuss. That is 8:30am Sydney time. If that is not convenient, I will call Krishna to arrange another time. Rajesh, Paul Stinson [ECT 05]

Owned/Supplied by :	TransPerfect Legal Solutions
Used by :	FRA, TransPerfect Legal Solutions

8.2.14 DISCO Software

- DISCO delivers the **fastest performance** in the industry, with **1/10-second search** and **1/3-second document viewing**, even in databases with more than 100 million documents and even for the largest and most complex file types. Upload up to 4 TB of data per day using DISCO's proprietary high-speed uploader.
- DISCO's **cloud-native review platform** automatically scales to handle matters of any size, with any number of users. DISCO releases new features and enhancements to all matters weekly using software-as-a-service (SaaS) delivery, requiring no upgrades or downtime – our clients have the latest and greatest software at all times.
- DISCO's review platform includes **all features for an end-to-end review**, including Westlaw- and Lexis-style search syntax, an interactive search builder, clickable search examples, search history, saved searches, mass tagging and foldering, customizable folders for database organization, batch print to easily export documents for use in witness prep, redactions including mass redactions and redaction reasons, search term highlighting and persistent highlighting, the ability to add your own users with role-based permissions, customizable tags and tag groups, and automatic search result indexes.
- **Full processing and analytics** to identify duplicates and near duplicates, normalize time zones, extract all metadata, recreate email conversations and parent-child relationships, and OCR and image documents up front for faster performance during review – all at no additional cost.
- **DISCO AI with Tag Prediction Technology.** DISCO's tag predictions powered by DISCO AI work within the flow of normal document review, and is enabled on matters at no cost. As you work, DISCO gives multiple coding recommendations for the document, predicting tags that are most likely relevant to the text. Furthermore, the software also scores tags that have been suggested or applied to the document on a -100 to 100 scale, showing predicted confidence and/or potential tagging errors.

DISCO's advanced AI is designed to help attorneys throughout the course of discovery by applying continuous learning on multiple review decisions concurrently. There is no setup or seed set creation required — just start your review. When the system has developed enough insight, it intuitively begins to display those recommendations to you in real-time.

DISCO's advanced AI gives precise predictions in a fraction of the time required for traditional review. As DISCO understands what is relevant to your review, it examines the document, taking into account the order, meaning of words, and sentence structure to arrive at intelligent insight as to whether the document is of substance to your review.

Chapter 8 – Supplier & Software Details

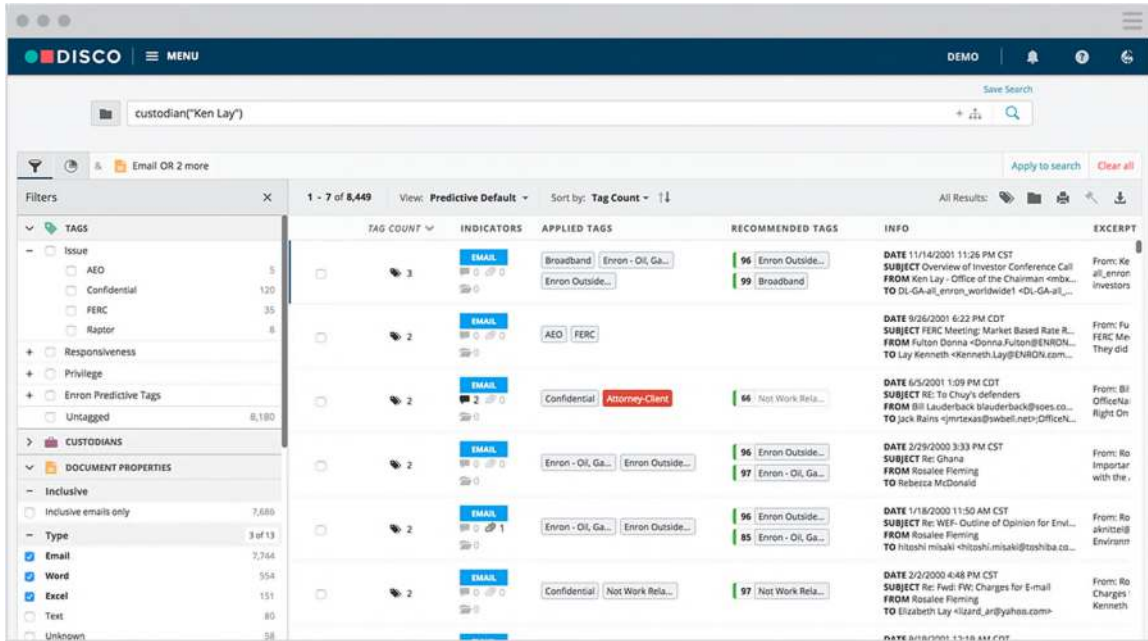

- **Automated workflow** allows a case team to organize a large review into a series of review stages (for example, “first pass review” or “issue review”) with customizable tagging panels and rules. The case team can then see what each reviewer is working on, can control access within a stage at the group level, and can see progress at the group or batch level.
- **Review metrics** provide transparency into overall review progress, including documents remaining, average pace for the review team and for individual reviewers, and an estimated completion date; help you identify problems early in the process, including reviewers who are outliers on specific review decisions or on their overall pace; and summarize what you are learning about the documents through your review.

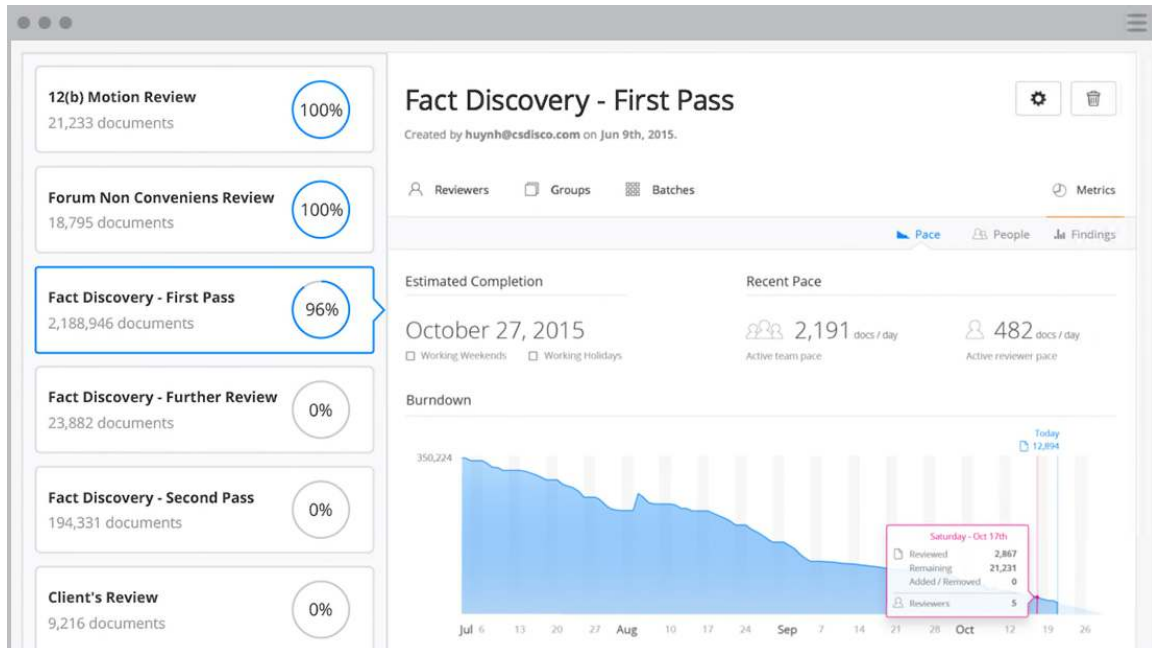

- **Quality control** lets you sample the review work product at any point to assess the quality of review decisions the team is making and to localize any problems by reviewer, custodian, document type, or other metadata field so that the problems can be corrected surgically without re-review.

Chapter 8 – Supplier & Software Details

- Search Term Reporting.** When negotiating search terms with the other side it can be difficult to know the scope or volume of documents (and their families) that any given search will return. Search term analysis resolves this issue by delivering a simple interface to cross-reference searches and see the result counts, family counts, and the **unique counts** of documents across terms. If you have received a set of search terms from the other side you can even drag and drop a .txt file containing terms straight into DISCO to save having to retype entries.

SEARCH TERM	HITS	UNIQUE	DOCUMENTS W / FAMILIES	HITS	FAMILIES UNIQUE
	1. (prepa! /3 transaction) % prepaid	328	328	566	200
2. "fas 140" "fas 125"	46	46	110	12	12
3. forecast model projection plan insolvent! "cannot meet" "cant meet" "will not meet" "fall short" guidance auditor! accountant!	36,434	36,162	45,678	13,775	13,768
4. ((delete! or alter! or destroy! or shred) /10 (document! email! evidence data laptop computer file!)) (retain retention)	42,943	31,878	51,909	14,662	10,771
5. (energy power) /25 (schedule! bid! estimate! forecast! description! characterization! analyst! evaluation! projection! plan! report!))	72,857	44,149	66,454	24,800	19,512
6. "fantasy football" or ((gambll or bet or wager) /5 football)	2,037	1,473	2,106	51	38
Total	154,645	114,036	166,823	53,500	44,301

- Native Excel Viewer.** Speed up your review of excels!. Now review your excels as you normally would in excel, search for hidden formulas and easily produce them natively as well.

	A	B	C	D	E	F	G	H	I	J	K	L	M
1													
2													
3													
4	LOAD (Incl.RGC,CFE)	829	832	815	828	840	874	783	834	829	834	829	822
5	TNP	80	50	50	55	85	80	70	75	75	75	75	75
6	Purchases												
7	Incremental Purchases												
8	4C Prescheduled												
9	4C Balancing												
10	4C Real-time												
11	PV Prescheduled												
12	PV Balancing												
13	PV Direct Bill												
14	PV Real-time												
15	Hedging Prescheduled												
16	Hedging Real-time												
17	Artesia Direct Bill												
18	Artesia Prescheduled												
19	Artesia Balancing												
20	Artesia Real-time												
21	Sales												
22	ID (150 MW)	59	84	75	75	75	75	84	108	108	108	108	108
23	PNM (50 MW)												
24	Incremental Sales												
25	4C PRESCHEDULED	25	25	25	25	25	25	25	25	25	25	25	25

- Searchable audit histories** for each document let you quickly find documents tagged by specific people between certain dates.

Chapter 8 – Supplier & Software Details

- Case teams can use **exhibit sets** to collect documents for depositions, motions, or trial. DISCO automatically numbers and labels exhibits, allows you to add titles and descriptions for cover sheets, include or exclude attachments, and output collated exhibits with an automatically generated index of exhibits ready for printing or e-filing.

Owned/Supplied by :	CS Disco
Used by :	Kennedys

8.2.15 DocBuster

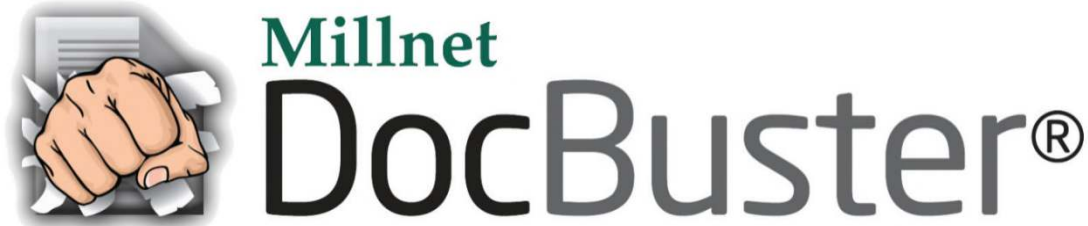

Millnet’s solution for batch printing, DocBuster® is powerful, fast and user friendly, taking the headache out of printing electronic documents. Developed in response to commercial law firms’ requirements and implemented in many of the leading law firms, DocBuster® is the definitive batch printing solution.

DocBuster is an integral part of Millnet’s 24/7 document operation, and is used by businesses across the UK. DocBuster makes it easy for law firms to batch print documents such as emails and their attachments, and common file types including Word, Excel and PDF. DocBuster is tried and tested technology, used within leading UK law firms. Millnet has printed in excess of 100 million pages of emails, MS Office documents (Word, Excel, PowerPoint), PDFs and other file types with the program over the past 10 years. DocBuster is easy to install, requiring little or no IT involvement.

DocBuster is designed to be

- Easy to Use
- Powerful
- Cost Effective

Main Features

- Page count reporting
- Identifies password protected and corrupted files
- Chronological ordering of emails
- Formatting of Excel spread sheets
- Page capping on large documents
- Detailed slip sheets, making it easier to identify a documents origin
- Plus many other features that will assist lawyers in their day-to-day work requirements
- UK based support, DocBuster is backed up by the largest outsourced secure 24/7 legal document production facility in the UK.

Owned/Supplied by :	Millnet Document Services
Used by :	Various UK law firms

8.2.17 edt Toolbox

One Database. One Search Engine. True Integration.

In the real-world litigation and investigations are iterative, fluid and unpredictable. Early data culling decisions often need to be revisited as a case evolves and new issues come to light. EDT software delivers a fresh approach and true integration. EDT was developed to analyse, filter and cull data at the earliest stages possible – immediately upon loading raw data into the software. The unique function of EDT significantly reduces data to be reviewed compared to other e-discovery solutions.

EDT cases have a single database that is shared by all processing, analysis, review and production functions. Therefore, no data need to be moved between multiple tools and there is no requirement to create load files. This single product solution delivers significant efficiency across the entire case lifecycle. This makes the EDT solution ideal as a portable solution for off-site jobs. At its core, EDT was designed for both e-discovery and investigative purposes.

Unicode compliant and customisable language indexing for foreign language document review.

EDT is an integrated 'all-in-one' eDiscovery solution. Backed by Microsoft SQL database EDT is open to users who wish to interact with SQL directly, and with a Command Line Interface to interact with other systems. A widely scalable solution, EDT is comprised of the following components:

Agent Service

EDT Agent Service is a processing engine used to execute tasks such as generating export packages and retrieving native files from source data. Multi-tasking efficiency and reliability is achieved through the execution of multiple agents, providing a truly scalable eDiscovery option for legal teams of any size, locations or workload.

Loader

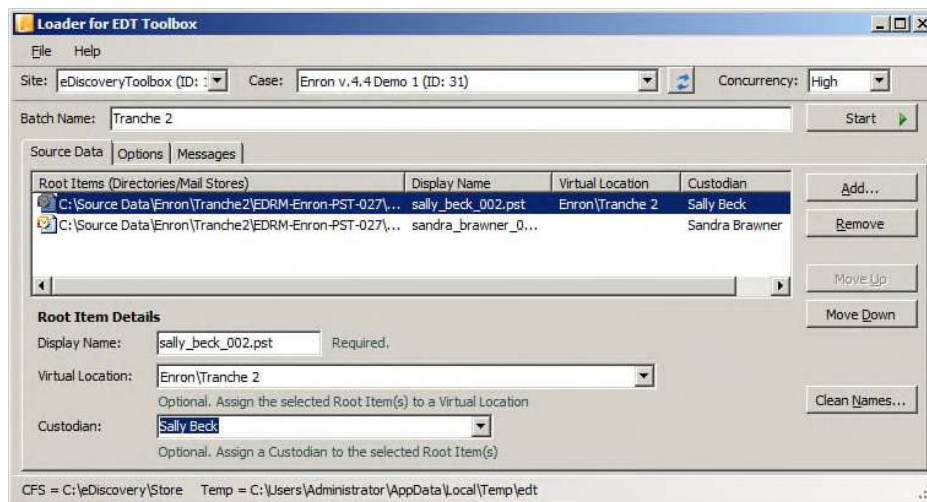

EDT Loader extracts and loads metadata from source data into a Toolbox case with an easy-to-use interface. The Loader enables you to select the source data to be loaded, assign custodians, remove unwanted file types and also set your duplicate, time zone and text extraction options.

Native data of multiple formats can be ingested, including pst, nsf, EDB and forensic image files. Hard-deleted documents can also be ingested from PST and OST files. All file information is added to Analyst for early case assessment, and processed data is made immediately available without needing to wait for the batch to complete. DT's Integrated OCR function also provides text for documents without extracted text.

Importer

EDT Importer is used to import documents via load files to Analyst or Reviewer. Importer is flexible and can use generic load files or those generated by other eDiscovery software. Existing documents sets can also be updated using Importer.

QA Manager

EDT QA Manager is used to clearly identify documents that have failed to process fully, then allow the user to efficiently apply fixes or use passwords as needed in order to complete the ingestion process begun by Loader.

Analyst

Analyst is an early case assessment (ECA) web browser-based interface that provides graphical tools to analyse and report on the documents ingested. Analyst shows metadata characteristics and filters to enable the promotion of priority documents to Review or removal of irrelevant documents, as well as interactive communications charts.

On-the-fly calculators estimate the potential costs involved in processing, printing and conducting legal review, and provides a proportionality check early on in the case lifecycle to compare these costs against the litigation budget and the amount at stake. Analyst is a key tool for planning effective disclosure strategies that keeps costs within budget and proportionate to the issues at stake.

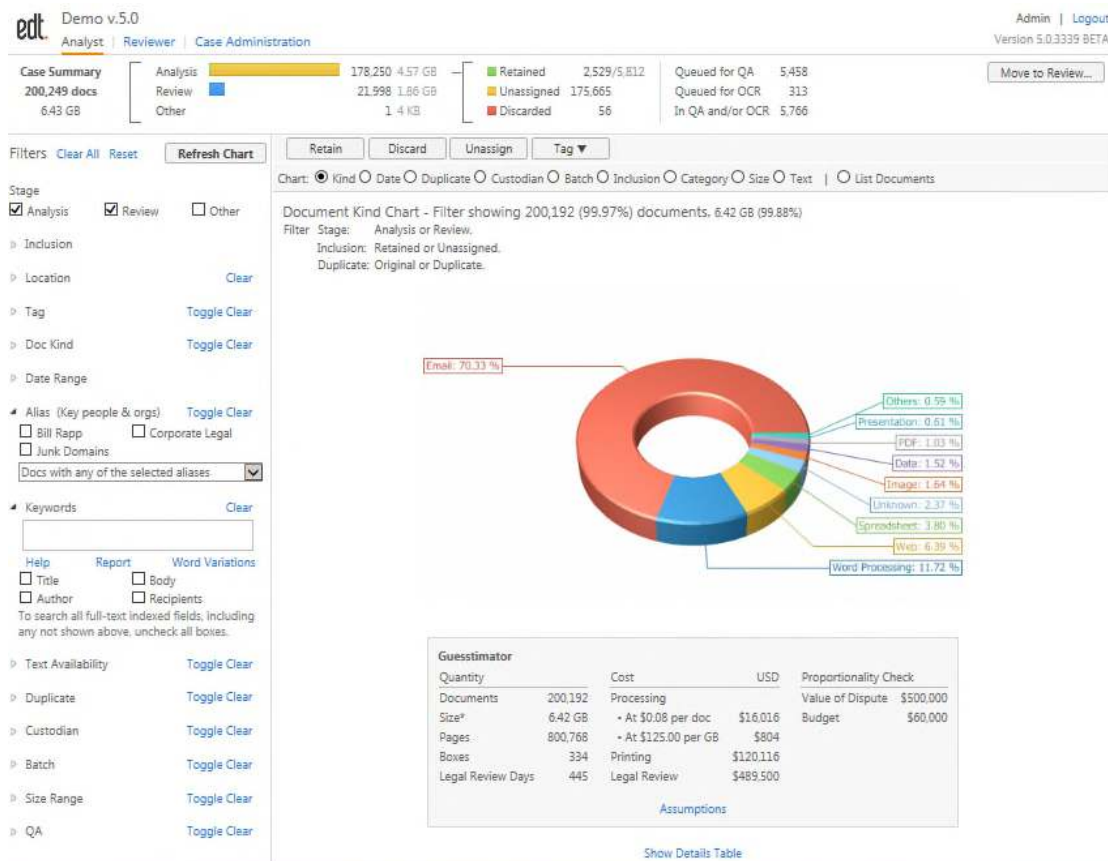

Chapter 8 – Supplier & Software Details

Communication Chart - Filter returned 73,837 (32%) documents

Filter Stage: Analysis
Inclusion: Retained or Unassigned.
Duplicate: Original or Unknown.

Chart the top 25 email addresses. Include: From To Cc Bcc | Put in 'Other' if less than 10% of the email sent to/from the top email address

Note: The chart displays the communications of email addresses in the emails returned by the filter. It typically does not display all documents returned by the filter.

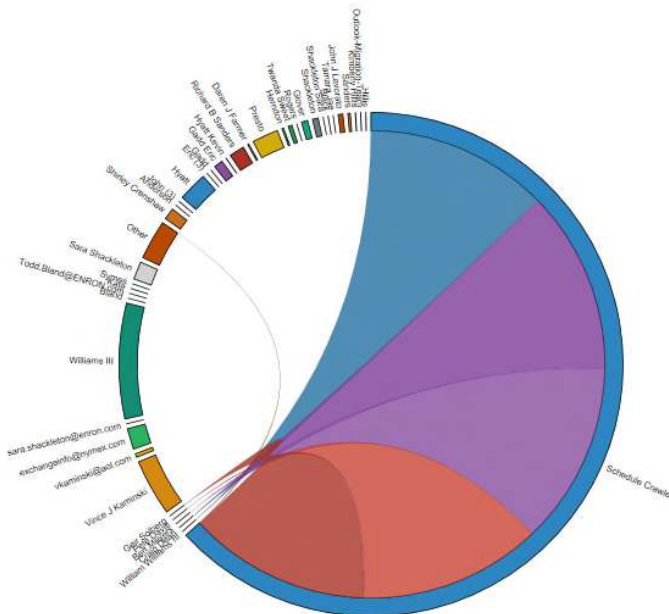

Reviewer

Reviewer is designed to enable legal teams to review large volumes of documents. It is an easy to use, web-browser based legal review platform that integrates seamlessly with the EDT suite.

Intuitive search features enable the user to build, save and load complex search queries. Also included is the Alias function which normalises multiple email addresses into one common 'Alias' name, allowing for documents to be searched from / to / between / among key individuals, organisations or domains.

Review is highly customisable, supports multi-level permission-based reviewers and is simplified with single-click tagging, intuitive search and browsing features, plus document redaction and annotation functionality.

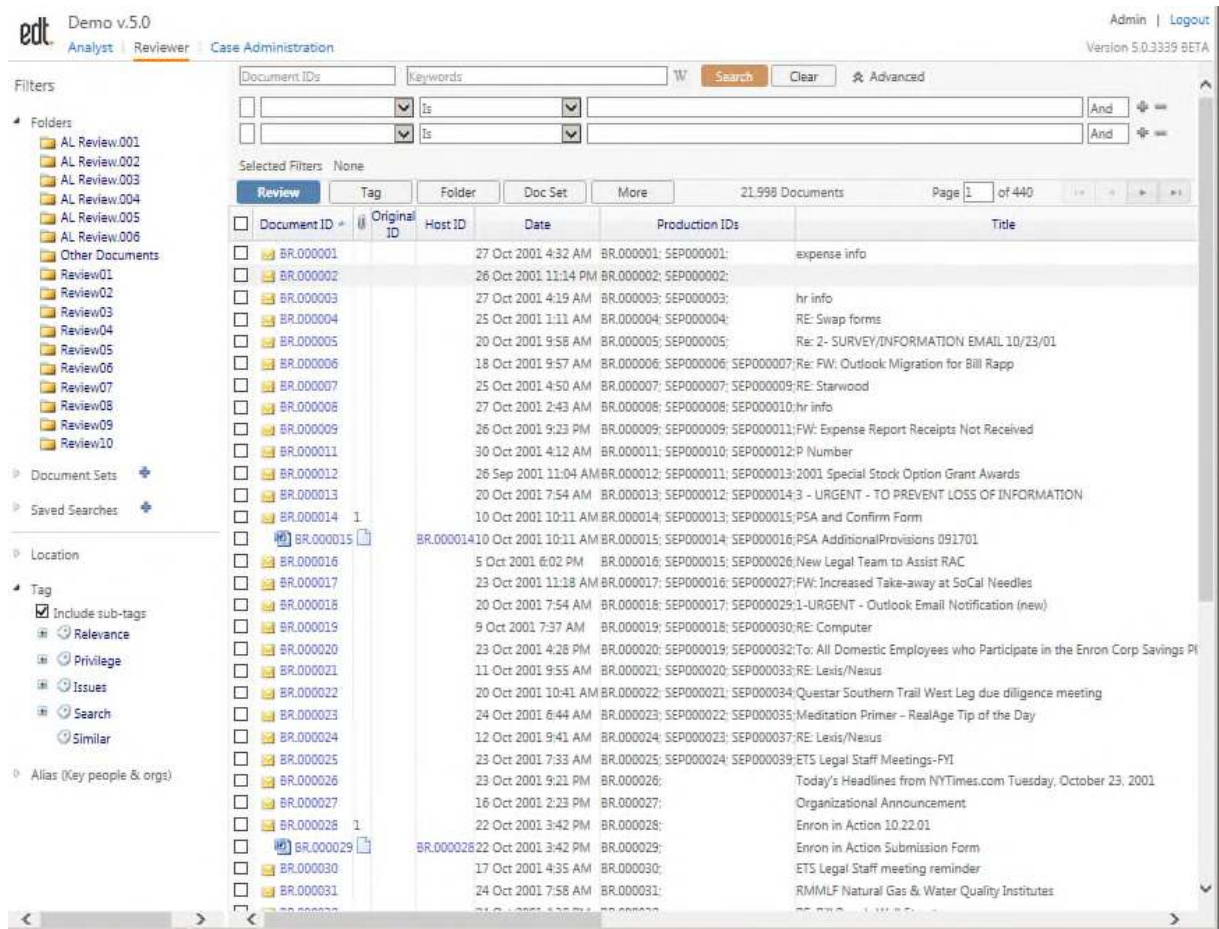

Chapter 8 – Supplier & Software Details

Documents are viewed in an HTML 5 Viewer, and can also be displayed in Text, Native, PDF or Tiff formats.

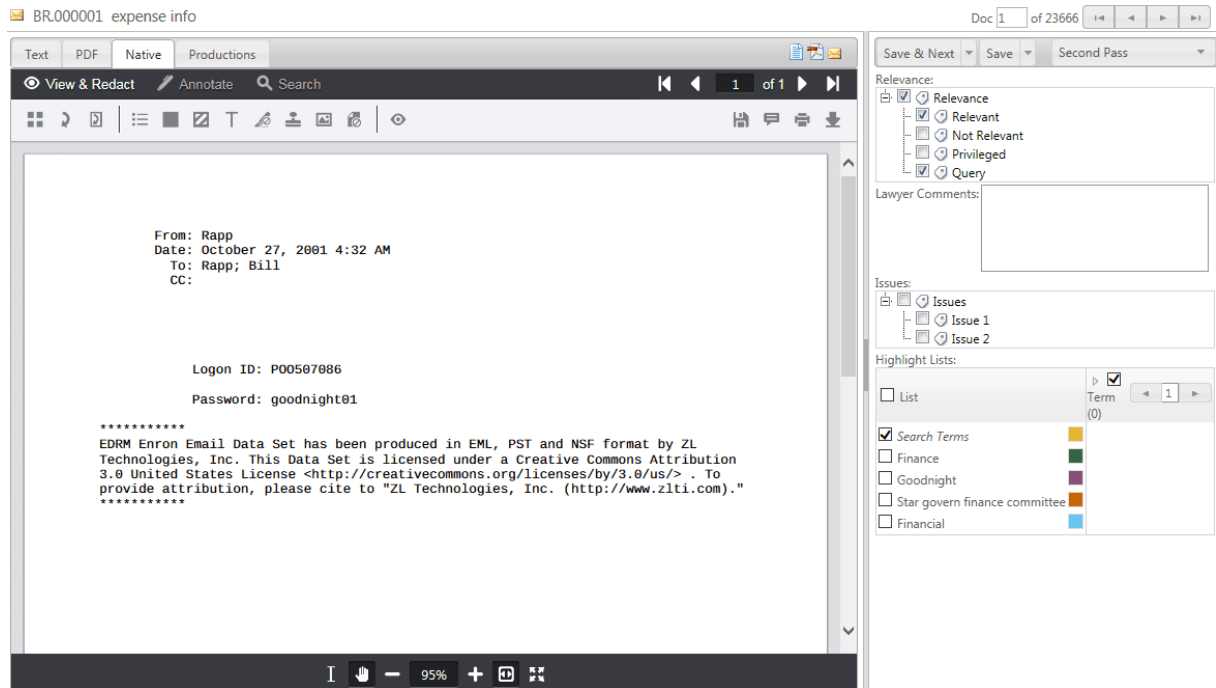

Documents in Analyst and Reviewer can be produced using an intuitive export tool. They are exportable in highly customisable formats for document production to Ringtail, Relativity, Summation, Concordance and other formats, including Native, Text, PDF or TIFF formats. This flexibility also enables the processing of selected data into load files.

Multiple Uses

EDT includes functionality for running cases in depositions, hearings, arbitrations and electronic courtrooms. Tools for these various use cases include an Exhibit Number allocation and stamping tool, a PDF Presenter viewer for comparing documents side by side, and a Copy page from Document function.

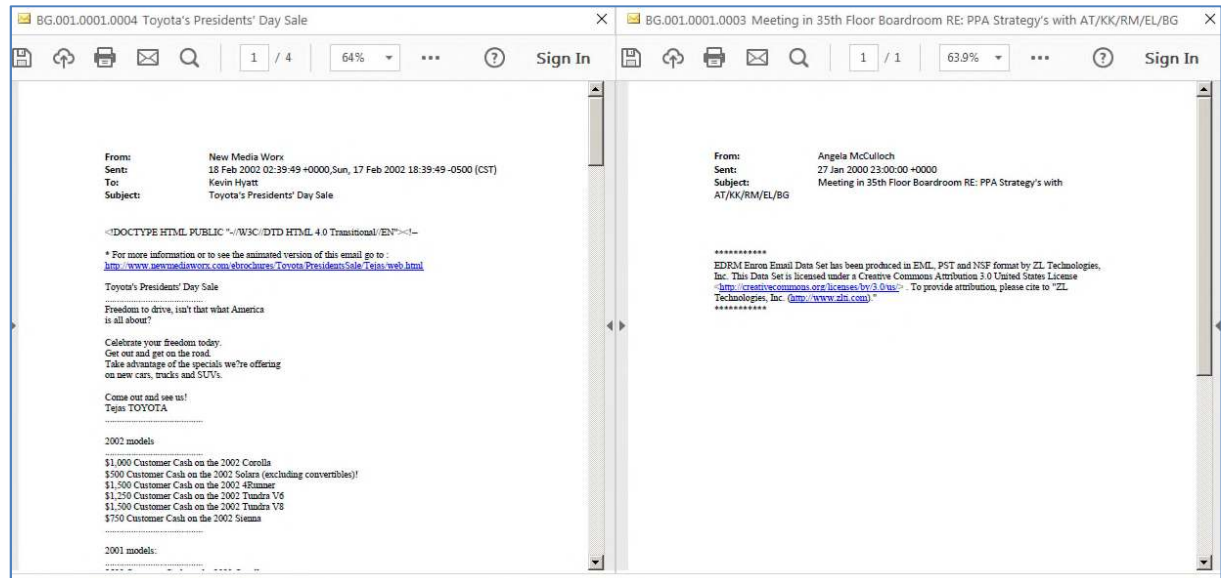

Chapter 8 – Supplier & Software Details

EDT's Compare documents feature allows you to compare two documents, displaying all similarities and differences between the selected documents. This is an ideal tool for use not only in review but depositions, hearings and trials.

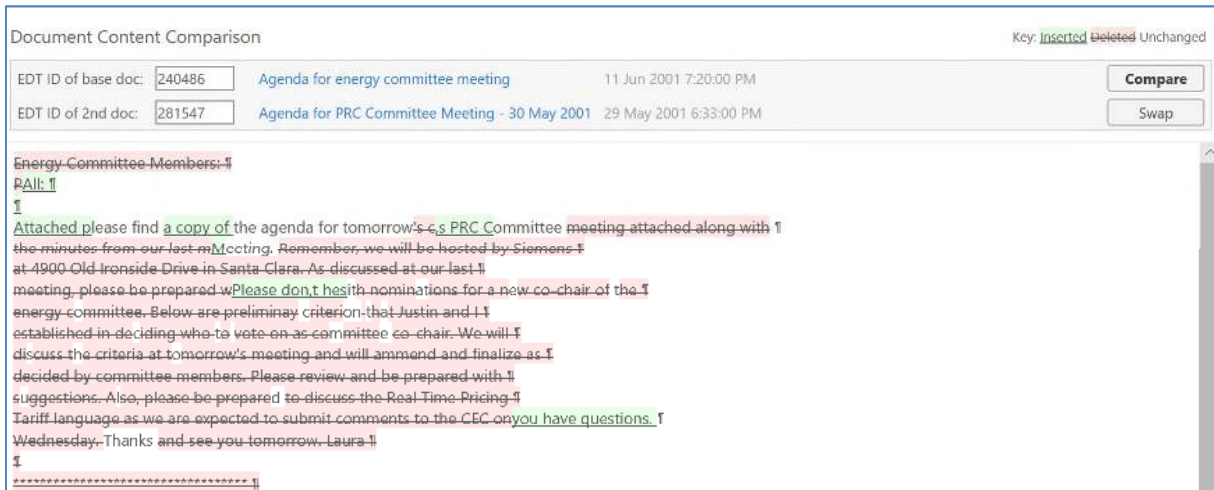

Service Information

EDT.BLUE

edt.BLUE is a turnkey solution which provides EDT software in your chosen cloud provider (e.g. AWS, Microsoft Azure or IBM) and location with a monthly pay-as-you-go fee. It is offered via accredited EDT partners and can be deployed within 48 hours in over 40 countries.

This allows you full control of your own processing, culling, batching for review and user management.

It is also ideal when you require in-country data residency because the data can't be moved from its location, for example on EU based projects where data privacy regulations mandate local hosting or data can't be transferred cross-border.

Simply nominate your international data center location from the 40+ countries available and an edt.BLUE instance can be implemented there within 48 hours.

There are no per gigabyte charges and no user fees but, rather, a simple monthly service fee for the infrastructure plus the software platform. There's no software or hardware to buy, support or maintain and you can expand and contract the storage and processing resources to cater for fluctuating demands.

Finally, you can avoid the complications of running back end infrastructure and focus instead on your core business – servicing your clients. You can even re-brand edt.BLUE so that your clients see it as your solution.

Owned/Supplied by :	edt
Used by :	<p>A number of corporate legal departments, law firm in-house litigation support departments, service providers, regulatory and government departments in the United States, Canada, Europe, Asia and Australia.</p> <p>Case Study with Allen & Overy available at http://discoveredt.com/support/documentation/</p>

8.2.18 Enterprise Vault

Key Features

- Unified Document Archiving Software Platform moves less-frequently accessed information off of expensive primary storage to lower-cost storage.
- E-Discovery and Search roles-based access for legal users to search, preserve, review and export electronically-stored information efficiently.
- Global de-duplication of Archived Content (i.e. email, files, SharePoint, IM, databases).
- Active Content Collection to extend search, indexing and classification of data beyond the archive.

Key Benefits

- Enterprise archiving reduces storage footprint and costs by up to 60% or more by moving de-duplication and compression closer to the source while retention and deletion policies keep information for only as long as it is needed.
- Streamlines backup and recovery times by moving older, infrequently accessed data from production sources into a centralised archive.
- Enables an in-depth search of Electronically-Stored Information (ESI) across the enterprise, giving organisations clear visibility into and control of the discovery, assessment, and management of unstructured and semi-structured information.
- Allows for immediate early case assessments, legal hold and review without manual, time-consuming collection processes.
- Quickly find all relevant information across email, SharePoint, files, IMs, etc., based on custodian and target searches to individual custodians within a case for increased search precision and recall.
- Extend compliance policies to sites such as Facebook, Twitter, and LinkedIn and preserve social media communications for eDiscovery requests.
- Extend governance to SharePoint. Archive SharePoint document libraries for storage optimisation and compliance. Archive SharePoint document libraries, wiki's custom SharePoint lists, social content and more.

Owned/Supplied by :	Veritas
Used by :	Veritas

8.2.19 Enterprise Vault.cloud

Key Features

- Cloud-based information archiving (no required hardware, software or client plug-ins).
- Intuitive end user experience with seamless archive access from Outlook, Outlook Web App, Notes or supported web browsers.
- Rapid search functionality and world-class collaborative eDiscovery workflow.
- Unlimited storage and retention for a predictable monthly fee.
- Support for Microsoft Exchange Server, Microsoft Office 365, IBM Lotus Domino, Microsoft SharePoint, Salesforce Chatter and Box.

Key Benefits

- Reduces the management burden for IT with rapid deployment and automatic upgrades and support.
- Expedite searches for archived information with scalable grid architecture and advanced, search-within-search capabilities that deliver results in seconds.
- Accelerate the legal discovery process by giving legal teams self-service access to the archive.
- Impose mailbox quotas without inhibiting user productivity by providing users with virtually unlimited mailboxes via their archives.
- Improve server performance and shrink backup and recovery times by storing information in the archive and confidently expiring messages saved on the mail server.
- Ensure email high availability with Enterprise Vault Mailbox Continuity.cloud, a failover system for your primary mail platform.

Owned/Supplied by :	Veritas
Used by :	Veritas

8.2.20 Epiq Software (DMX and TMX)

Epiq DMX (DocuMatrix) – Epiq’s eDiscovery business intelligence platform

Dashboard

With its focus on easy-to-use business intelligence, DMX provides data insights, while still providing the ability to process and review terabytes of data.



Offering end-to-end transparency throughout the eDiscovery process, DMX provides a holistic picture of data flow: from the original data sources to what’s been processed to what was ultimately reviewed and produced. And most importantly, how all this information is woven together seamlessly in an interactive and easy-to-use dashboard.

The DMX dashboard shows users:

- The stage in which the data resides
- Where each data source has been
- The data and custodians included in the current data set
- Data size and document count
- Current velocity of the review

With the DMX dashboard, data from previous projects can easily be referenced to inform decisions about future cases. The platform allows our clients to interact with the data and find information that never would have been revealed otherwise.

Review

The DMX platform equips our clients with essential discovery management tools to achieve an efficient, intelligent assessment and review with features such as:

- Advanced analytical features to triage data early in the discovery process and identify documents vital to the matter, leaving you with a smaller, more focused data set
- An automated workflow that reduces the risk of human error and keeps data and crucial steps from falling through the cracks
- Foreign language capabilities via fully-customizable workflows that support 195+ languages
- Secure multi-party project collaboration
- Review accelerators that can increase review speeds by up to three times, dramatically reducing document review costs

Processing

DMX delivers the most powerful data processing in the industry. Excavating deep into data files, DMX fully extracts metadata, text, embedded objects and domains, ensuring critical information is not missed. DMX is continually strengthened to handle a wide range of diverse data formats, including Lotus Notes, Bloomberg data, Unix Mail, chat, wikis, SharePoint, audio and video files, as well as emerging data types, such as social media.

Moreover, as DMX uses the native application interfaces, all data loaded remains in a native format that can be recognized and reviewed online instantly. This eliminates the need to adjust the data or any TIFF or PDF conversions.

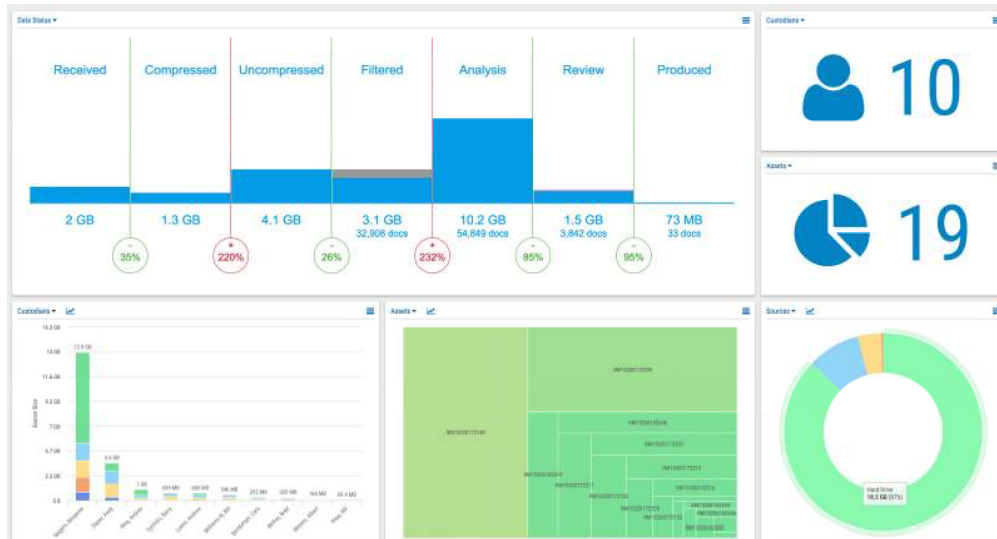

Figure 1. DMX dashboard

Epiq TMX – Collaborative platform for case preparation and presentation

“TMX is a secure, flexible, and highly scalable sharing platform that gives our international clients the ability to build electronic bundles quickly and easily for court hearings and arbitrations, while giving our U.S.-based clients a single collaborative tool with which litigation teams can prepare case documents for depositions and trial,” said Cliff Dutton, chief innovation officer. “For legal professionals, TMX delivers an intuitive, adaptable platform that fully bridges the gap between document production and trial.”



TMX enables:

- Collaboration between legal teams, experts, and clients
- Bundle creation in a flexible, familiar, and intuitive platform including folder structuring, pagination, and index generation
- Easy-to-use functionality such as searching, annotation, tagging, hyperlinking, and the presentation of transcripts and documents
- Private and shared workspaces configurable to the demands of the parties and the case

TMX is available immediately in Europe, and will be available in North America, Asia, and Australia later this year. To find out more, click [here](#).

Chapter 8 – Supplier & Software Details

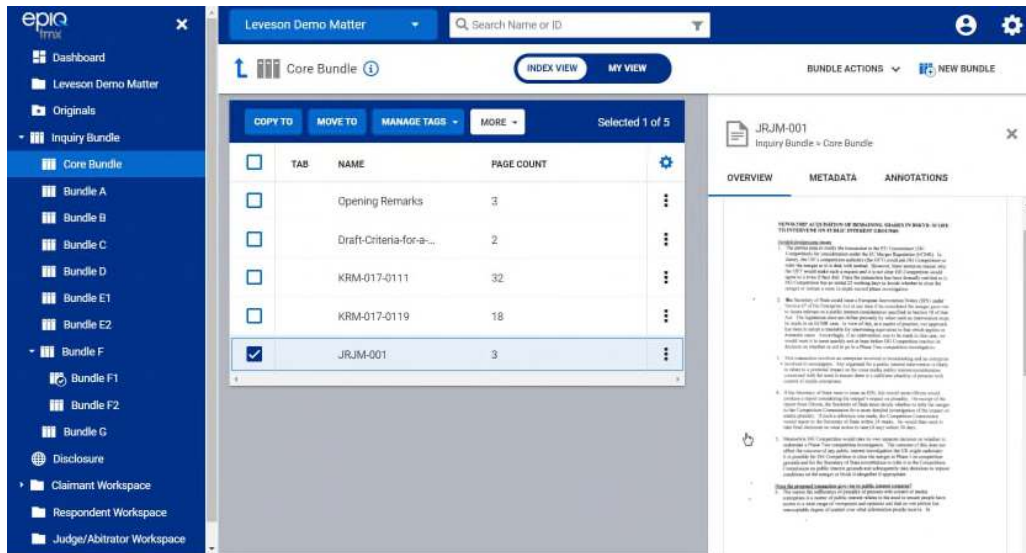

Figure 2. TMX. Seamlessly and easily move or copy documents between folders

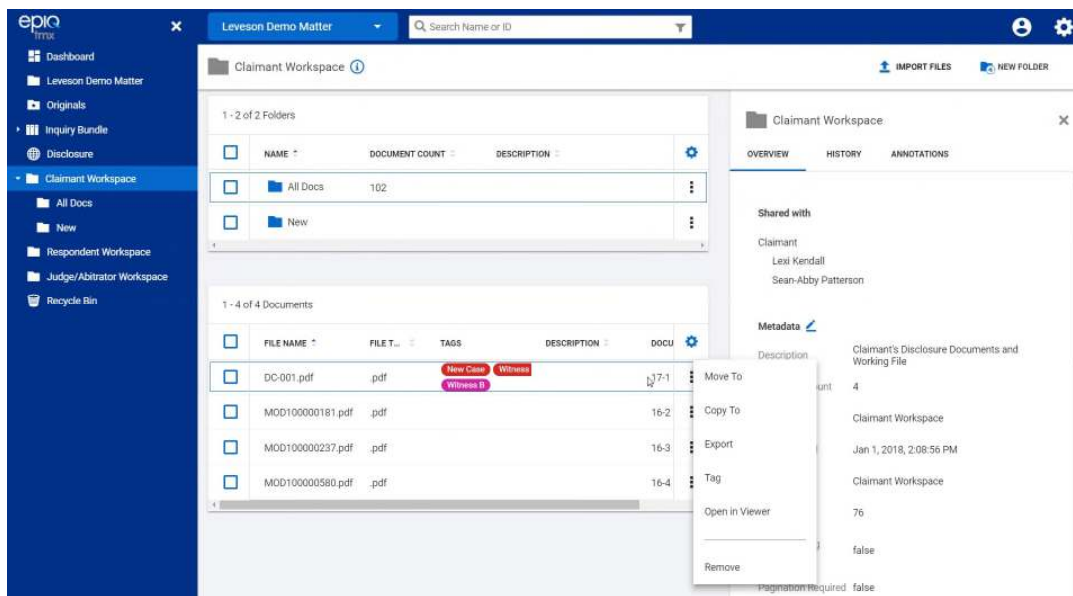

Figure 3. TMX. Quickly assess document content with our comprehensive preview panel

Owned/Supplied by :	Epiq
Used by :	Epiq

8.2.21 Equivio Relevance

Equivio Relevance is a lawyer guided software tool for scoring documents by relevance. From a sample of documents that have been classified by a lawyer as ‘relevant’ or ‘not relevant’, the software generates relevance scores for all documents in a collection. Equivio Relevance can be used at various stages in the legal document review process to save time and cost including:

- Initial case assessment – to rapidly assess key issues
- Culling of irrelevant documents that are responsive to typical keyword / phrase search techniques.
- Prioritisation of review – start the document review with the most relevant documents
- Post-review quality assurance – to assist in identifying review inconsistencies.

How does the Service Work?

1. The documents to be ranked for relevance are selected. For instance, they may be documents identified via the application of searches / filtering by say custodians, date range, file type etc. Alternatively, they may be the documents as selected by the client or documents received on disclosure.
2. The collection of documents to be reviewed are firstly de-duplicated and text extracted from electronic documents such as Word, email, PowerPoint etc. and for hard copy or scanned files text is created via optical character recognition ‘OCR’.
3. The text from the files to be reviewed is loaded into the Equivio Relevance software. There is the option to ‘seed’ the review with sample relevant documents and / or keywords. Alternatively, the software will select a representative batch of 40 documents for the lawyer to review.
4. The software is simple to use and does not require any training (see screenshot below). All that is required is for the lawyer to read the text from each document and decide whether the document is ‘relevant’ or ‘not relevant’. Note that it is also possible to review documents by ‘issue’.

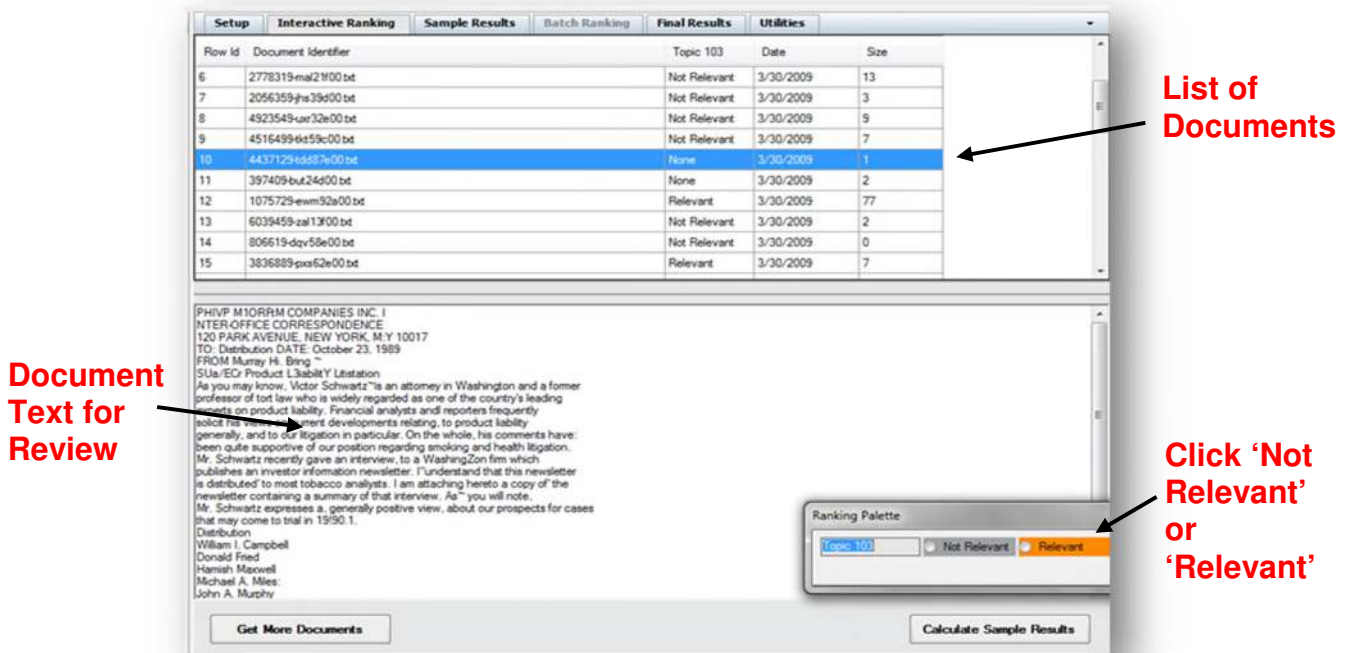

- The software presents to the lawyer batches of 40 documents at a time. Upon completion of each batch of 40 documents the software takes between 2 and 5 minutes to assess the results and create another batch of 40 documents for review. In the background, the Relevance software is effectively ‘second guessing’ the lawyer’s classification of documents. The process typically requires between 30 and 45 batches of 40 documents each (i.e. 1,200 – 1,800 documents) to become ‘stable’ (see the screenshot below showing the number of batches reviewed and progress towards reaching ‘stability’). ‘Stable’ means the software has reached a point where it is correctly assessing the relevant / not relevant classification in line with the lawyer review with a high degree of consistency.

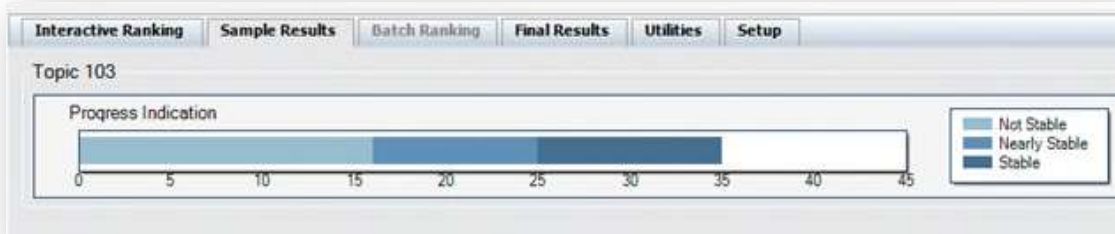

- At completion of the review process, the software typically takes between 1 and 3 hours to calculate a ‘relevance score’ for all of the documents in the collection. The score is a number between 0 and 100.
- The Relevance software also provides useful statistics including a list of keywords / phrases used ranking in relation to the importance the software has placed upon such words / phrases in relation to determining the ‘relevant’ and ‘not relevant’ status of documents (see below for an example screenshot).

Include:		Exclude:	
Keyword	Weight	Keyword	Weight
brand	0.20	tobacco	-0.13
value	0.18	day	-0.09
display	0.17	received	-0.07
accounts	0.16	were	-0.07
field	0.14	ph	-0.07
stores	0.14	vantage ultra	-0.06
program	0.14	tbe	-0.06
spanish speaking	0.14	protocol	-0.06

- Depending on the nature of the documents to be reviewed, it is normal to find that the relevance scores are grouped towards either end of the 0-100 scale. The final analysis includes various statistics including a graphical representation of the distribution of the relevance scores (see screenshot below) so as to assist with formulating an approach to reviewing documents thereafter.

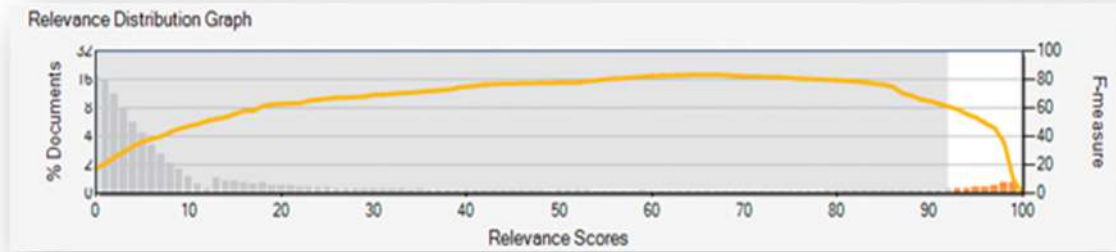

9. Finally, the documents along with their relevance score are loaded into an online review platform such as Relativity, CaseLogistix or Concordance. The legal review team can then use the relevance score to prioritise, quality check and potentially eliminate documents with very low relevance scores.

Owned/Supplied by :	Equivio (Acquired by Microsoft in January 2015)
Used by :	<p>AlixPartners, Epiq, FRA, Legastat, Lighthouse.</p> <p>Equivio is often embedded into other litigation support products (particularly Relativity) to provide "Predictive Coding" functionality.</p> <p>Expect this to change as Microsoft terminate support for embedded options as contracts with suppliers expire.</p>

8.2.22 Everlaw

Everlaw is a collaborative, cloud-based litigation platform for in-house counsel, litigators and the government that enables teams to discover, reveal, and act on information to better drive internal investigations and positively impact the outcome of litigation.

Unlike slow, unwieldy, client-server software and expensive third-party service providers, only Everlaw combines speed, security, and ease-of-use into a unified, comprehensive solution that unlocks the collaborative power of teams and enables them to investigate issues more thoroughly, uncover truth more quickly, and present their findings more clearly.

The platform provides three primary capabilities, enabling organizations to Discover, Reveal & Act:

- **Discover:** Ingest, organize, search through, and review massive troves of data in order to discover and produce relevant underlying information.
 - **Data ingestion:** Everlaw accelerates the document review process by enabling reviewers to upload their own documents, plugging in seamlessly with third-party cloud hosting platforms, and ingesting documents quickly.
 - **Search:** Everlaw's instantaneous search results occur with even the most complex search strings. The ability to visually build searches allows both novice and power users to narrow their searches without concern of the elusive missing parenthesis.



- **Review:** Providing exceptionally fast 'doc-to-doc' review speeds and shortcuts like coding presets, users are able to complete their review significantly more quickly on Everlaw. Native documents are supported and text documents, as well as native spreadsheets, can be easily redacted.
- **Productions:** Everlaw users can create on-the-fly disclosure lists in our cloud-based production environment. Additionally, Everlaw gives the ability for user driven productions allowing the ability to generate, modify and share legal document productions at any time.

- **Reveal:** Harness the power of modern computer science to expose the hidden details of documents at scale.
 - **Hidden data analytics:** Automatically translate, transcribe and convert hidden data, bringing to the surface the information that often remains hidden during document review.
 - **Predictive Coding:** Enables reviewers to use their standard workflow--assigning ratings, codes, and attributes to reviewed documents--in order to teach the system how to find more relevant documents on their behalf.

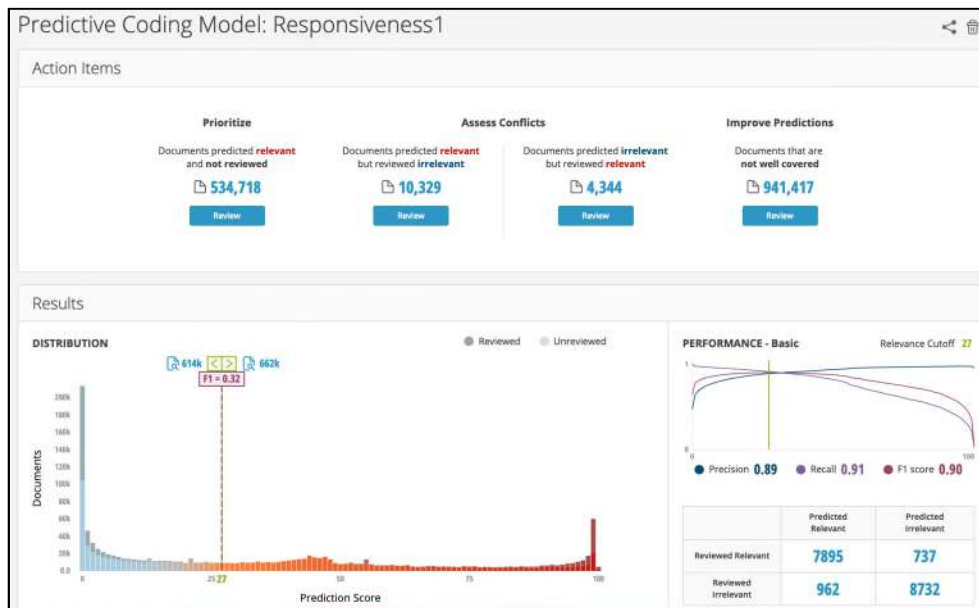

- **Data Visualization:** Interactive visualizations from any set of documents that provide key insights into document dates, metadata, contents, formats, review activity, and predicted relevance.

- **Act:** Collaborate securely with colleagues, business partners, inside or outside counsel to craft narratives and efficiently manage the end-to-end process of investigations or litigation.
 - **Secure collaboration:** Everlaw enables sharing and communication directly in the platform to promote secure, seamless collaboration.
 - **Narrative building:** Story-building ensures collaborative alignment of investigative teams, improve workflow, reduce risk, and save time by organising key documents into a compelling narrative.

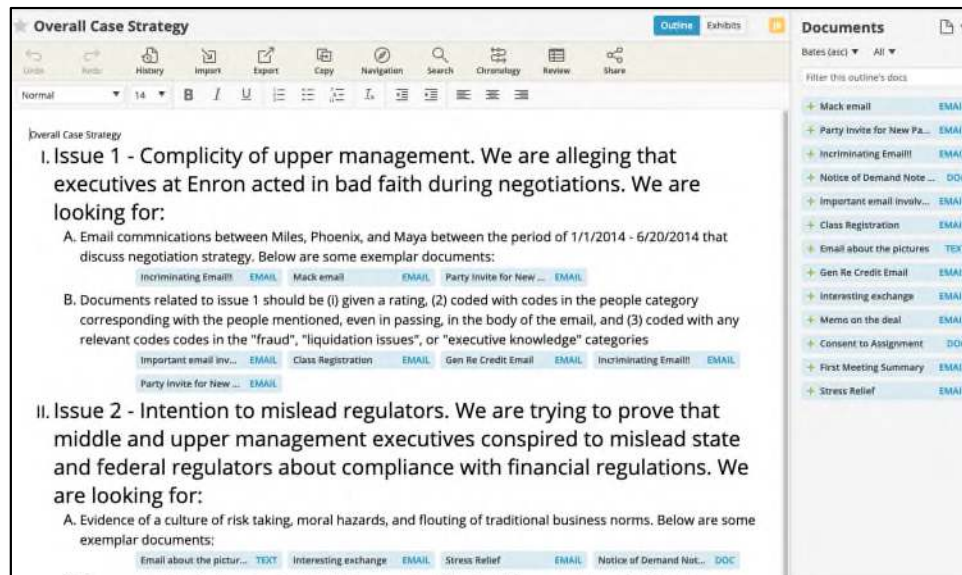

- **Matter Management:** Integrated project, user, and case matter management tools allow for more efficient project outcomes.

To deliver on these promises, Everlaw started with a dramatically different philosophical approach, centered on **six key principles**:

1. Security and Compliance

At Everlaw, we prioritize keeping important data safe with enterprise-class security protocols and privacy standards. Data security is foundational to our core philosophy. We are fiercely protective of client data, which is why we take a proactive approach to data security. As a provider of cutting-edge software for customers with highly confidential data, we recognise how important security is to protecting information. We understand that the security of our product and the compliance culture of our business are instrumental in maintaining the trust our customers place in us, and we are committed to protecting that information. Many of our cloud competitors are also hosted on AWS, but that is where their security measures come to an end while our approach to security goes much further. Everlaw is SOC 2 Type II certified, and both HIPAA and GDPR Compliant. We host data on AWS instances in the country that data needs to reside with live instances in the US, UK, Canada, EU, and Australia.

2. Respect for Users:

This core value is represented throughout our platform and in the way that we function as a company. Our goal is to deliver elegant solutions with thoughtful design which makes for happy software users who can not only get their job done, but even find enjoyment in the process. We are focused on long term success with our partners, so that means we aren't interested in making quick changes to the platform that don't align with our long term strategies.

3. Bias for speed:

Big data can be synonymous with slow data, unless software is specifically built for modern data volumes. Everlaw is built to provide lightning fast performance no matter the size and scope of the case. We're built for Petabytes. 10x faster than Relativity and 5x faster than nearest cloud competitor in processing and productions.

4. Rapid innovation:

Everlaw delivers impactful new features every four weeks via the cloud; this ensures that customers stay in front of the curve and keeps us "close to the code" (bugs don't linger).

Releases are automatically deployed for every case, at no cost. When we released audio/video transcription, we automatically reprocessed every audio/video file on the platform so that all existing customers could access the benefit of this feature. We release products broadly because we don't believe our customers should have to manage version control or change management.

5. Transparency:

We believe that when information is open and available, outcomes are more efficient for everyone. There are two main ways that we think about transparency.

- First, transparency is built into the product itself. Everlaw provides exposure to reporting at the case level as well as at the organization level, allowing our partners to closely manage their projects and the associated costs.
- Second, transparency is built into our pricing, which manifests itself in our service model. Service at Everlaw focuses on educating users about our platform; everything is designed to be self-service but we have a dedicated team to support and provide training at no additional charge to our customers. This keeps our pricing transparent, removing any gimmicky PM time from being billed. We believe in enabling our customers to fully leverage our advanced functionality without depending on us for solutions.

6. Enabling Technology

We leverage modern technology -- like machine learning, where appropriate -- for solving complex computer science challenges. Just as a builder chooses steel over wood, depending on the structure, we don't brand ourselves as the "AI company" or the "cloud company" because we believe in leveraging the best technology available at that moment in time. We picked AI and cloud computing because they are the best software distribution technology available, today. But as quickly as technology will change we will continuously adapt in order to provide the most cutting edge technology, just as we have over the last 8 years.

Owned/Supplied by :	Everlaw
Used by :	Weightmans

8.2.23 Exego (Planet Data Software)

Exego Extract is our exclusive processing engine that revolutionized the eDiscovery landscape. Granted two Patents for extracting and indexing embedded text, Exego technology completely and accurately processes data that most other engines miss. Exego is particularly effective in dealing with embedded objects, encrypted data and other complex file types - making lengthy exception reports a thing of the past. Specifically, Exego handles Bloomberg® Terminal mail and chat like no other platform in the business. Exego Extract then seamlessly delivers a more complete set of fully processed data to Exego Select for pre-review.

Completely processed data - including the most difficult file types like Bloomberg®, Lotus Notes®, mobile data and embedded text - is normalized, and appears in Exego Select, ECA and pre-review, ready to be fully searched and indexed along with the rest of your typical eDiscovery data. Families and attachments are properly reconstructed to maintain the email relationship to its attachments. Without this custom development, during document review, the reviewer would not be able to view or understand the relationship to the attachments. Best of all, you will have access to many TAR tools in Exego Select that are not typically available in ECA (such as email threading, bulk tagging and robust reporting) at no additional cost.

Exego Review provides our clients with the final piece of our end-to-end discovery solution, featuring a detailed dashboard, collaborative tools, and an expert hosting team standing by. All of this without ever leaving the agile and convenient Exego interface. Exego Review is completely web-based, and PC and Mac compatible. With easy-to-navigate features, clients can track team and individual review progress at a glance, personalize screen content and layout, and increase speed and efficiency. Secure password resets, customizable workflows, dynamic coding, proximity highlighting, multiple redaction capabilities round out the list of features available within a few clicks. Of course, Exego Review users can rely on the same powerful reporting that they are already accustomed to in Exego Select.

Relativity is a complete review solution with the power to handle the largest and most complex electronic discovery projects and the ease-of-use to let users focus on documents, rather than on technology. As a feature-rich online review platform, Relativity provides image and native file review, powerful searching, diverse coding options, flexible workflow capabilities, [integrated productions](#), [Unicode and foreign language support](#), and concept searching.

Owned/Supplied by :	Planet Data
Used by :	Exigent, Planet Data

8.2.24 ExhibitManager

ExhibitManager is the intelligent and user-friendly software that supports litigators and arbitration practitioners in legal proceedings, from collecting and reviewing documents, to writing legal submissions, as well as creating exhibit bundles and interactive eBriefs.

We have developed ExhibitManager in collaboration with leading international litigation and arbitration lawyers. ExhibitManager frees you and your team from the distractions associated with handling exhibits in large legal submissions so that you can concentrate on your core competence: advocacy.

ExhibitManager perfectly adapts to your daily workflow: Exhibits and other evidence are stored in the ExhibitManager database. Searching, reviewing and inserting exhibits into your submission become an easy, straightforward process. Exhibits will be automatically numbered and formatted according to your specifications. Once you have finished your submission, ExhibitManager generates the necessary lists of exhibits and bundles. You can even create interactive eBriefs in PDF format with a few mouse-clicks.

Litigators and arbitration practitioners from many jurisdictions are using ExhibitManager. You may fully adapt the numbering and formatting of exhibits to suit the requirements of your Code of Civil Procedure or Arbitration Rules.

ExhibitManager promotes teamwork as all lawyers working on a legal brief are accessing the same documents. Team members benefit from ExhibitManager during case analysis, when writing and finalizing legal submissions:

1. Case analysis

You may organize exhibits in different ways, e.g. by tags/issue, by exhibit number, chronologically etc. OCR and full-text search exhibits to find relevant information in a user-friendly document previewer. You can annotate exhibits and share knowhow within your team.

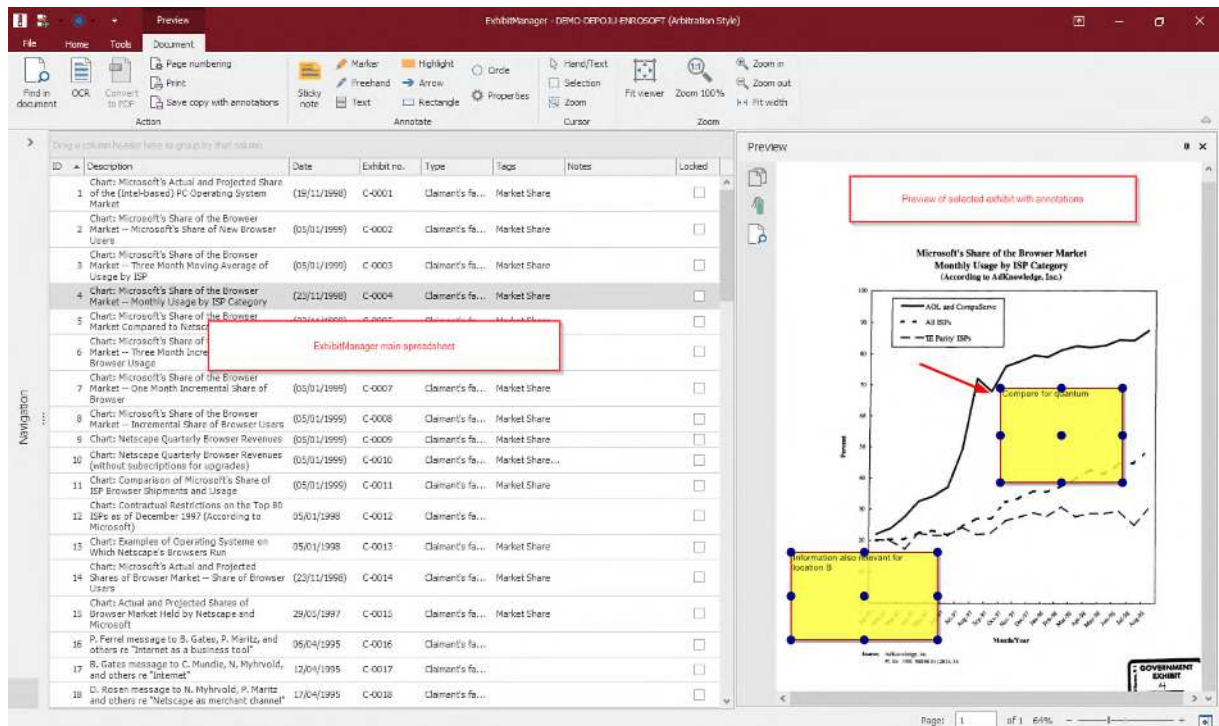

Description Screenshot 1: ExhibitManager main view; left: overview of organized exhibits by tag/issue, right: exhibit in preview with annotations.

2. Writing legal submissions

Insert exhibits into your legal submission with uniform and fully customizable styles. Exhibits can be numbered automatically. They may be updated with a single mouse click when their order has changed in your submission.

- Update exhibits in multiple documents at the same time (e.g. Statement of Claim and all witness statements).

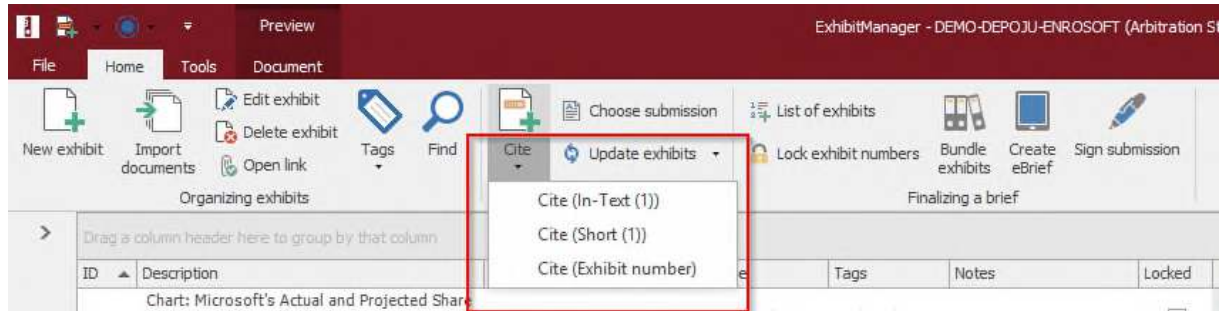

Description Screenshot 2: Citation Buttons and Button update exhibit numbers

ExhibitManager integrates seamlessly with Microsoft Word: You can easily review exhibits cited in the submission by right clicking on the exhibit citation.

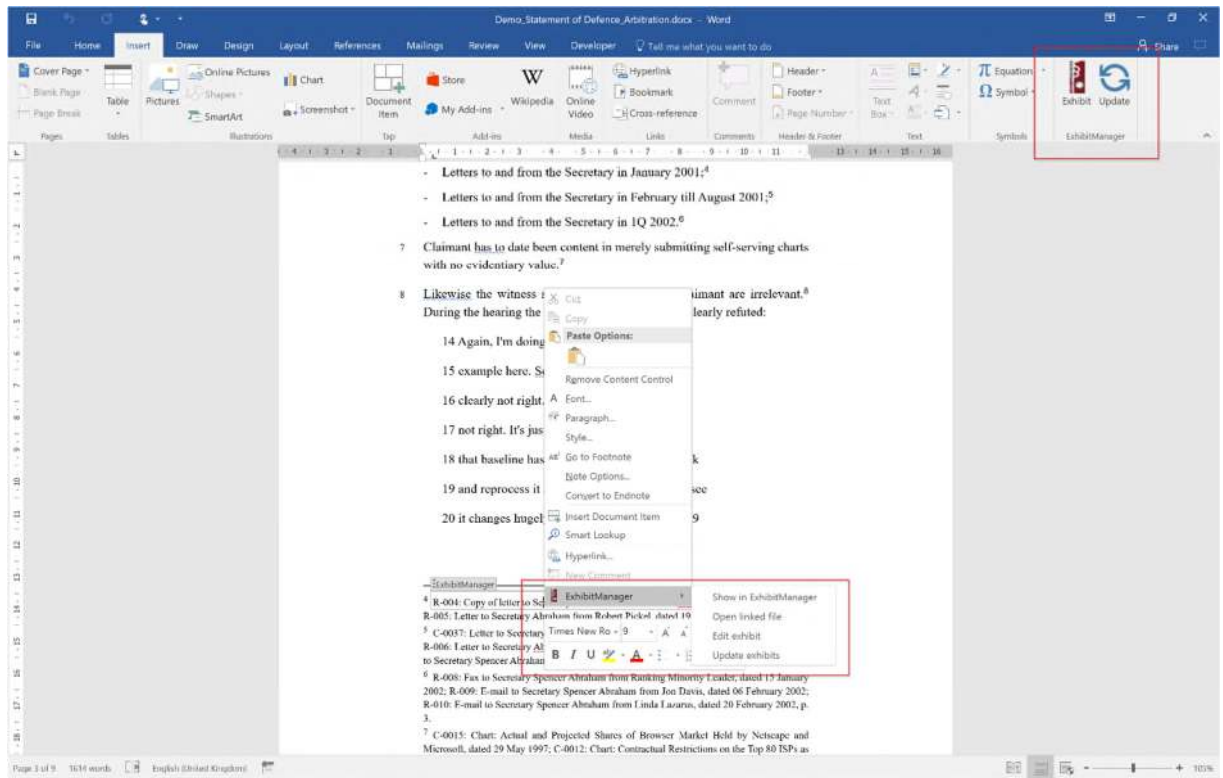

Description Screenshot 3: ExhibitManager offers reviews of exhibits when working in Microsoft Word.

3. Finalize submissions

ExhibitManager supports you in various ways when finalizing your submission:

- **Lists of exhibits** can contain one or more exhibit type (e.g. Claimant's fact exhibits) and be ordered by exhibit number, chronologically, or by order of appearance. Creating combined chronological lists of exhibits is now a matter of seconds.
- ExhibitManager creates **bundles** and stamps exhibits automatically. In addition to the exhibit number, stamps may include any additional information such as draft, version etc. All documents in the electronic bundle are named properly.
- ExhibitManager creates **customized trial bundles**.
- Create a **hyperlinked eBrief** (.pdf or .docx format) of your submission with a few mouse clicks. No more external service providers are needed. This saves you valuable time and you can do last minute changes, if necessary.

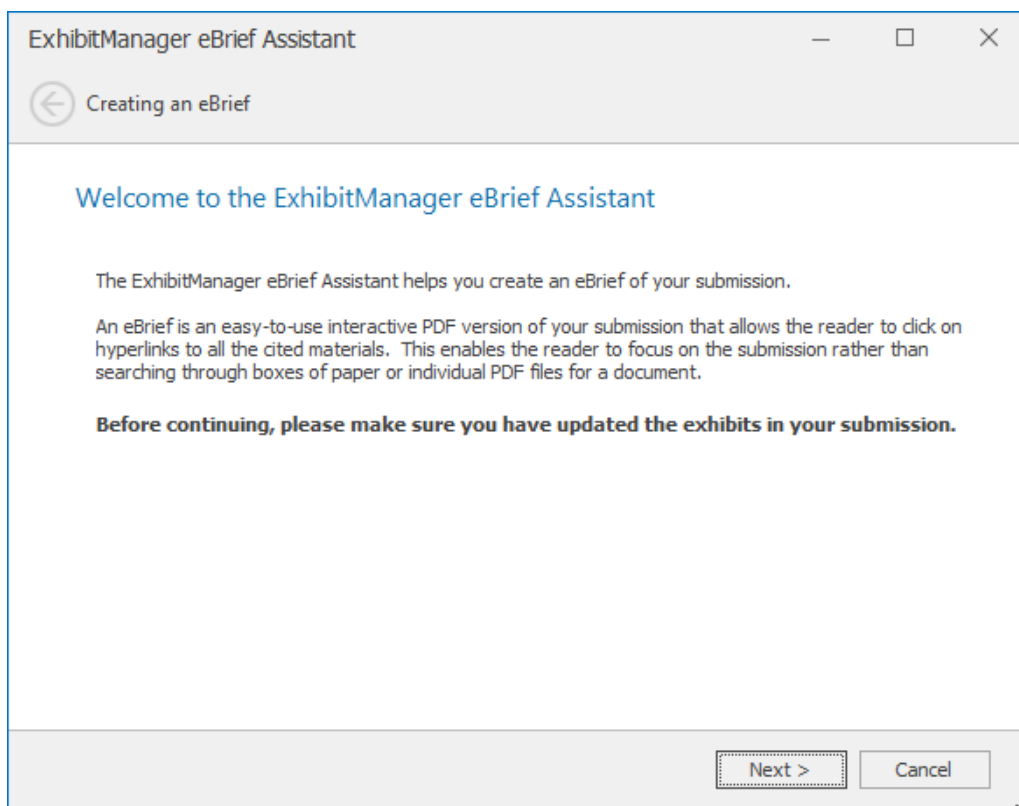

Description Screenshot 4: eBrief Assistant to create your eBrief within minutes.

For more information, please see the video [“Introduction to ExhibitManager”](#).

System requirements

- Microsoft Windows Vista, Windows 7, Windows 8 or Windows 10 with .NET 4 framework installed.
- Microsoft Word 2016/2013/2010 or 2007.
- ExhibitManager uses an embedded, industrial-strength SQLite Database (included). Alternatively, the ExhibitManager database can be run on a Microsoft SQL Server 2005 or newer (MS SQL Server licenses are not included). This configuration is particularly recommended for larger teams working on one project concurrently.

Owned/Supplied by :	Causasoft LLC
Used by :	Causasoft LLC

8.2.25 Exterro Software Suite

Exterro Orchestrated E-Discovery enables customers to manage, measure, and optimize e-discovery processes, unifying all e-discovery phases and all internal and external stakeholders on the same technology platform. Information is available anytime, from anywhere. The result is that clients are able to complete the e-discovery process in far less time and at a much lower cost.

Exterro software solutions that can be deployed on premise or in the cloud:

EXTERRO DATA MAPPING The only application designed to create a data map of all of your company’s electronically stored information (ESI). It enables legal teams to rapidly identify the most relevant ESI repositories to a legal matter and eliminate those that add unnecessary cost and time.

EXTERRO LEGAL HOLD Widely recognized as the gold standard for legal hold software for Global 2000 companies. Designed for paralegals up through the General Counsel, Legal Hold’s ease of use and rich feature set power immediate productivity gains.

EXTERRO OFFICE 365 EXPLORER Significantly reduces the time, money and resources needed to get to the facts of your matters by enabling you to quickly identify key data and custodian relationships. This unique product gives you the ability to assess data stored in Office 365 without having to scan or index it first.

EXTERRO E-DISCOVERY DATA MANAGEMENT The sole data management solution on the market that identifies the most important ESI before collection. Features advanced, innovative design in which processing happens during collection, and almost immediately produces content for review, “collapsing” the process and dramatically decreasing the amount of time it takes to get to the facts of a case, while also slashing costs and eliminating the need for technical intermediaries between the software and legal users. Encompasses collection, processing, review and production. Incorporates the latest innovations in artificial intelligence in the ECA and Review stages.

EXTERRO PROJECT MANAGEMENT The only purpose-built project management system designed specifically for eDiscovery. Leveraging built-in workflows and intuitive dashboards, Project Management automates repeatable processes for consistent, high quality projects.

EXTERRO EMPLOYEE CHANGE MONITOR Employee Change Monitor reduces operational risk by replacing error-prone manual processes with automated, pre-defined actions appropriate to employee status changes. Employee Change Monitor mitigates the risk of electronically stored information (ESI) spoliation and court sanctions when employees under a legal hold depart or change roles.

EXTERRO FILE ANALYSIS Exterro File Analysis provides the critical foundation for any Information Governance project by delivering key insight into your unstructured data assets.

Owned/Supplied by :	Exterro
Used by :	Exterro

8.2.26 eZSuite (KNOVOS)

Cutting-Edge Technology for e-Discovery & Information Governance

eZSuite™

eZSuite is a complete, full-spectrum platform that covers the entire litigation lifecycle, eliminating the need for any third-party plug-in solutions. The suite comprises of 4 independent but seamlessly integrated modules:

- eZProcess - The data capture module
- eZAnalytics - The analytics module
- eZVUE - The knowledge management/ECA module
- eZReview - The workflow/review module

eZProcess™

At the heart of eZSuite is eZProcess, a robust data treatment and processing solution that provides maximum control and agility in managing electronically stored information.

- Data Inventory Audit
- Data Treatment and Culling
- Exception Handling and Management
- Rich Content and Superior Data Quality

eZAnalytics™

A powerful content intelligence and data mining module that allows users to gain powerful insight into their documents.

- Near-Deduplication
- Content Clustering
- Key Phrases
- Entity Analytics
- Email Threading and Domain Analysis

eZVUE®

An information management system and Early Case Assessment platform, eZVUE's comprehensive analytical features and intuitive visual interface help users understand and filter large quantities of data.

- Intuitive User Interface
- Powerful Concept and Content Searching
- Built-in Budget Reporting
- Work Product Reusability Within and Across Matters

eZReview®

Renowned for its design, functionality, and ease of use, eZReview allows users to rapidly review electronically stored information (ESI) and assess even the most complex cases. eZReview is scalable and customizable to specific unique case requirements, complete with advanced analytic capabilities and customized workflows.

- Automated Workflows Configuration and Review Rules
- Built-in Quality Control Mechanisms
- Integrative predictive coding module, ADP

CAPITAL NOVUS
Governance | Compliance | E-Discovery

Owned/Supplied by :	KNOVOS
Used by :	KNOVOS

8.2.27 FRA Software Suite

True Portable DATA Processing – Anywhere in the World

The FRA Mobile Solution is a comprehensive, end-to-end eDiscovery processing and Review platform, scalable to handle complicated project requirements, and can be installed on-site independently or integrated into the client's infrastructure anywhere in the world. FRA developed this solution using its decade long experience in working collaboratively with law firms in implementing robust data privacy compliant solutions. Multi-national corporations and their counsel have used the solution extensively as an important tool in accessing the data required to address cross-border issues without breaching in-country data constraints or compromising relationships with key stakeholders.



Solution

The *FRA Mobile Solution* comes packaged in a laptop, desktop or server (depending on the case requirements) and can be mobilized within days to process and review data on-site anywhere in the world. When data cannot be moved from its origin due to data sensitivity constraints (for personal, corporate or government reasons such as data protection, state secrecy, commercial secrecy, or intellectual property), FRA's solution allows secure processing and review at the source. Applications include internal or external investigations, regulatory responses, dispute resolution, or compliance audits.

The system is stand alone and can be shipped to any location where local regulations or sensitivities may restrict the transfer of data across borders. FRA has successfully deployed this solution in a number of jurisdictions including Uzbekistan, Switzerland, Italy and France. FRA's knowledge of technology, coupled with in depth understanding of local data restrictions, allows FRA to support multinational clients efficiently in handling complex cross border issues.

Technical Specifications

Capacity and Throughput

Laptop:	Process up to 100GB/24 hours – up to 1TB (1,000GB)
Desktop:	Process throughput > 100GB/24 hours Standard capacity of 5TB (5,000GB) scalable up to 14TB (14,000GB)
Server:	Process throughput > 200GB/24 hours Standard capacity 12TB (12,000GB) scalable up to 40TB+ (40,000GB)

Solutions

Processing engine: Digital Reef

Review platform: Relativity

Data Privacy Management Suite (DPM)

FRA's software development team created the DPM suite in response to our client's legal obligations to manage data privacy in several jurisdictions. This application is often implemented on projects that involve a European discovery element.

DPM is a rules based system that is flexible enough to manage on the most complex of cases. Rules can be applied at the project level, custodian level or individual media

level. A full audit trail is maintained within the system which can be exported to support any disclosure that is provided to regulators or opposing parties. DPM is wholly owned and maintained by FRA.

Exclusion Rule Hierarchy

Exclusion rules can be defined at multiple levels, as described in the table below:

LEVEL	DESCRIPTION
Project	This is the highest rule level, and will apply to all custodians and media in the project.
Custodian	Rules defined at the custodian level will apply to all media for the specified custodian.
Media	Rules defined at the media level will only apply to the specified media.

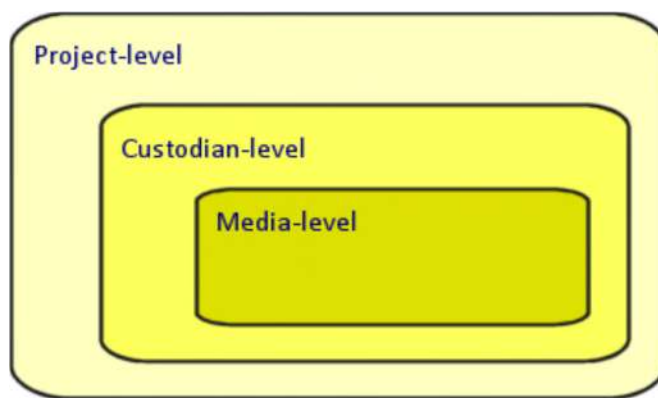

Fig 1 - Rule level hierarchy

Exclusion Rule Types

Several types of exclusion rules can be defined:

RULE TYPE	DESCRIPTION
No Exclusion	Specifies that no exclusion rules should be applied for the project, selected custodian, or selected media.
File Path	Any file path containing the rule's text will be excluded from searches.
Sender\Recipient	Any emails between the two parties defined in the rule will be excluded from searches.
Email Subject	Any emails containing rule text in the email subject will be excluded from searches.
Email Folder	Any email folders containing the rule's text will be excluded from searches.

Accessing Exclusion Rules

Data privacy exclusion rules can be viewed, added, and edited from within the MediaWebApp utility. After logging into the web application, click on the Exclusion Rules link (shown below) within the navigation section of any page.

Chapter 8 – Supplier & Software Details



After clicking the Exclusion Rules link, the Exclusion Rules page will appear. If no rules presently exist for the selected project, the page will appear with a message stating that no rules were found for the project:

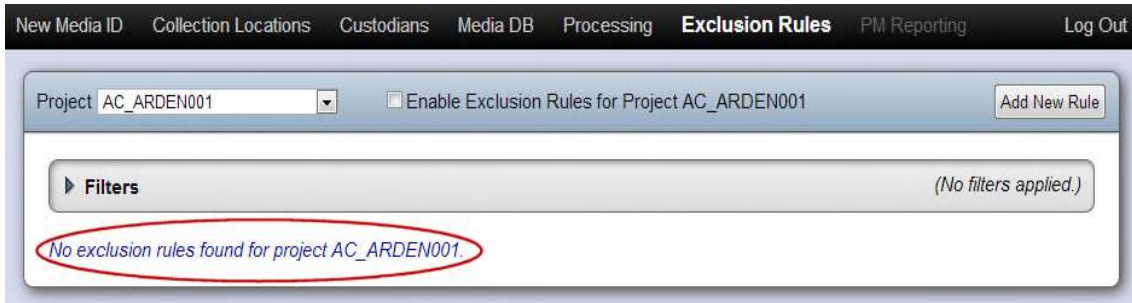

When rules do exist for the selected project, they'll be shown in a table:

The screenshot shows the 'Exclusion Rules' page for project 'AL013'. The 'Enable Exclusion Rules' checkbox is checked. Below the filters, a table displays the following data:

	Project	Active?	Level	Rule Type	Value 1	Value 2	Custodian	Media	Comment	Created By	Created	Edited By	Edited
Edit	AL013	<input checked="" type="checkbox"/>	Custodian	File Path	\\My pictures\				Added per spreadsheet in ticket request 2408.	crayan	7/1/2013 3:58:52 PM	crayan	7/1/2013 4:04:47 PM
Edit	AL013	<input checked="" type="checkbox"/>	Custodian	Email Folder	\\Personnel\				Added per spreadsheet in ticket request 2408.	crayan	7/1/2013 3:59:11 PM	crayan	7/1/2013 3:59:11 PM
Edit	AL013	<input checked="" type="checkbox"/>	Custodian	File Path	\\Mesdocuments\CB\utile\				Added per spreadsheet in ticket request 2408.	crayan	7/1/2013 4:01:58 PM	crayan	7/1/2013 4:01:58 PM
Edit	AL013	<input checked="" type="checkbox"/>	Custodian	File Path	\\Commercial\travail\cb\utile\				Added per spreadsheet in ticket request 2408.	crayan	7/1/2013 4:02:13 PM	crayan	7/1/2013 4:02:13 PM
Edit	AL013	<input checked="" type="checkbox"/>	Custodian	File Path	/Services France/Photos/				Added per spreadsheet in	crayan	6/28/2013 4:42:40	crayan	7/1/2013 1:18:58

(Each of the columns in this table can be sorted by clicking on a column header.)

A full audit trail is maintained within the system which can be exported to support any disclosure that is provided to regulators or opposing parties. DPM is wholly owned and maintained by FRA.

FRA-Early Case Assessment (ECA) Tool

The FRA-ECA tool has been developed to provide a streamlined way to understand the make-up of complex processed data sets at the earliest opportunities. FRA's project managers have the ability to guide clients through various reporting options to validate or corroborate expected outcomes based on the data that has been collected. Several key components of the ECA tool include:

- Reporting on de-duplicated totals in real time and within hours of the data being uploaded.
- Reports by custodian.
- Reports by file type.
- Keywords can be tested for responsiveness.

Chapter 8 – Supplier & Software Details

- Review strategy can be determined based on document numbers, language type or file type.
- Exception volumes can be determined such as the number of encrypted files.
- Billing accuracy can be determined due to real-time data volume reports.

ECA works seamlessly with all of FRA's hosted review environments and data staging platforms.

When a user first logs into the ECA tool they are taken to the home page which provides key information about the project, such as the total document population, the method of de-duplication, the number of custodians and media within the project.

Early Case Assessment

Home

Navigation [Disconnect](#)

Refresh

Home Searches Results

Project Name: Enron DEMO DATA
Description: ** DEMO **
Project Manager: Meg Hinton
Relationship Manager: Frances McLeod
Country: US
Review Platform Database: [No Server Defined],[No DB Defined]
Number of Custodians: 78
Total Project Media: 97
Default De-duplication Setting: Within Custodian (Multiple active rules)
Total Documents in Universe (Size): 631475 (62.9306 GB)
Total Documents Subject to Searching (Size; Billable Size): 631475 (62.9306 GB; 18.0565 GB)
Total Documents in Review Platform (Billable Size): 0 (0.0000 GB)
Oldest Document Load Date: 9/3/2013 4:19:59 PM
Newest Document Load Date: 9/3/2013 5:52:25 PM
Number of Searches Created by You: 8
Total Number of Searches: 17
Number of Running Searches: 0

Project: EN001 (Enron DEMO DATA) Database: EN001_IMPORT On: EDD-US-SQ01 Logged in as: cryan

Searches

The Searches page acts as the main “hub” for the selected project. The Searches screen displays a list of all searches that have been created for the project, and it also provides an interface for creating new searches.

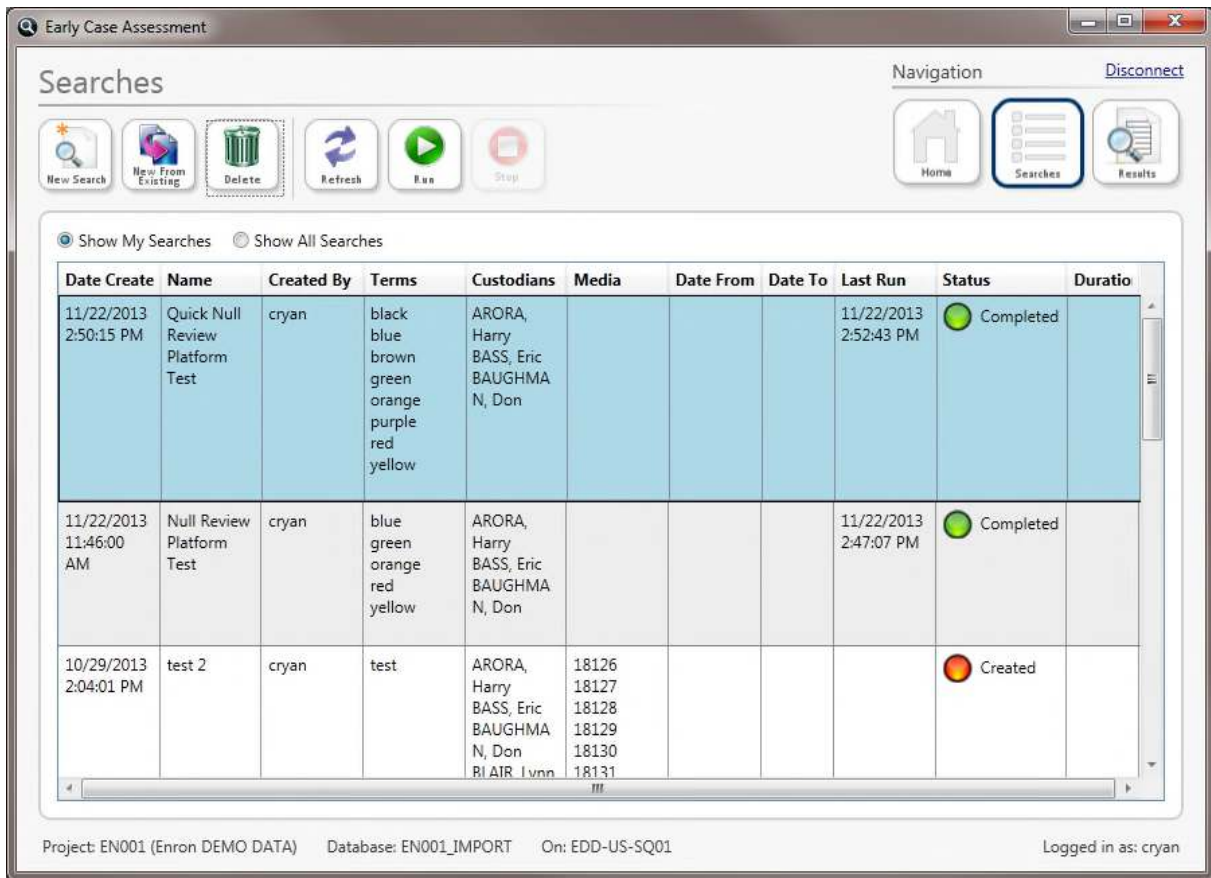

New Search Screen

The New Search screen provides an interface for creating new searches for the currently selected project.

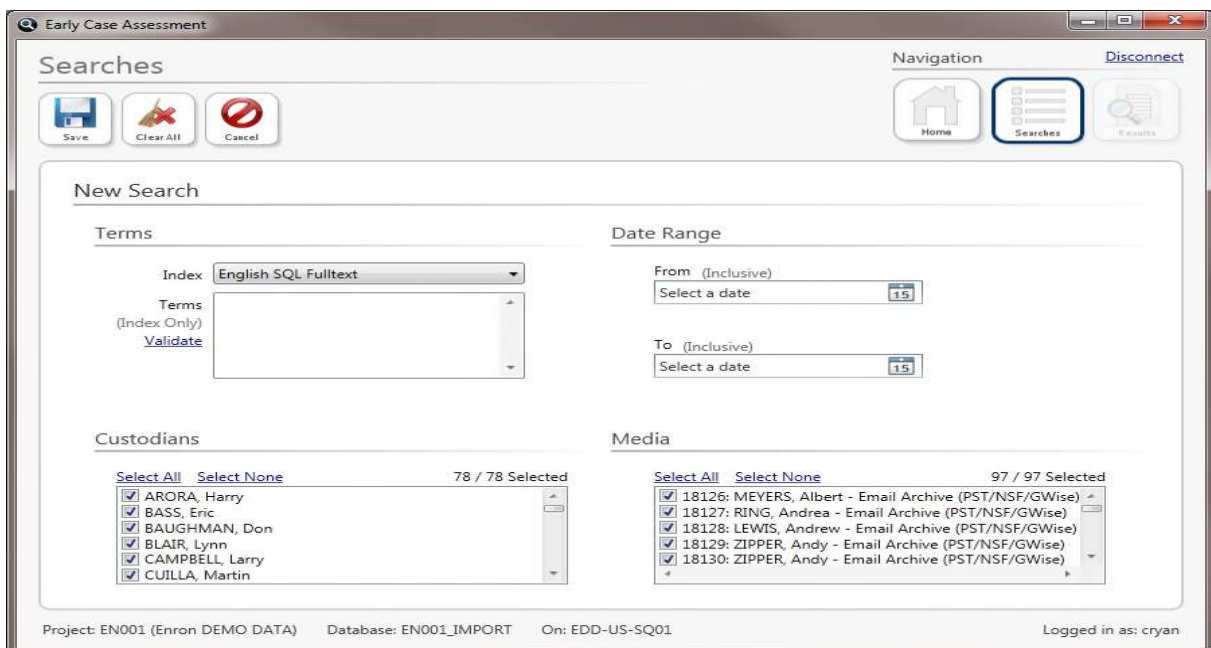

Search Results

The Search Results screen will only be enabled for searches that have been completed.

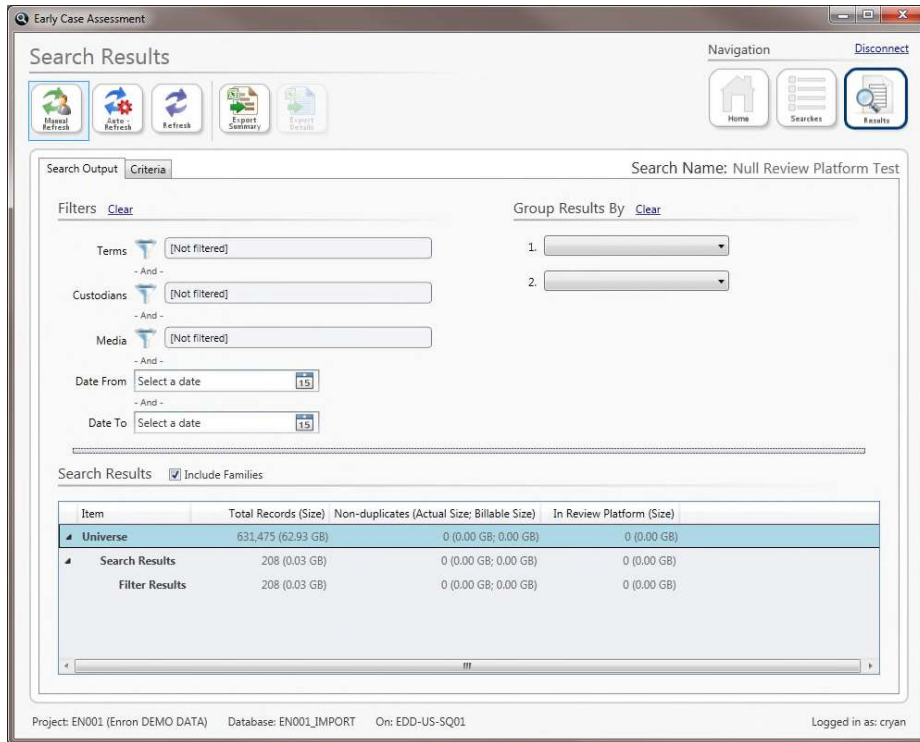

Reports can be generated and exported to Excel for further analysis. FRA clients can instantly reap the benefits of analysing their data sets well in advance of reviewing any documents.

Owned/Supplied by :	FRA
Used by :	FRA

8.2.29 In Control (Reveal Data Systems)

InControl is a disruptive technology that will change the way you do business. Having a superior eDiscovery platform helps clients save time and money while preparing for litigation, performing a criminal investigation, or preparing for a merger. But even with the flexible and easy-to-use InControl system, discovery still takes a significant amount of time. Reveal Data provides the advanced intelligence solutions needed to maximize efforts during discovery and investigation. InControl's fully integrated analytics can be used at any point in a workflow, on any project, to help our clients identify patterns in their data, glean critical insights, and to focus their efforts to get to review faster. Our analytics empower legal teams to create the best strategy for success and close their investigation faster. Our platform can be installed on a client server or used in the cloud, giving legal teams the freedom to work on eDiscovery anywhere at any time. The cross-browser compatibility and support for multiple languages ensures our clients have the ultimate freedom.

Our suite of offerings includes:

Forensic collection. Reveal Data employs a team of forensic data specialists who are at the ready to help uncover the information needed. We have designed the InControl Crawler in parallel with our advanced methodology to uncover the forensic data, wherever it lives. Our in-house specialists can also provide expert testimony or help to secure it from other appropriate experts.

InControl Crawler is an innovative enterprise search platform that provides the flexibility to find the data needed when needed. This advanced network search solution facilitates quick and easy searching across large data repositories, both locally and remotely. Our comprehensive platform works for businesses of every size and type that traffic in large volumes of data. It improves organisation, finds documents fast, creates comprehensive reports, and preserves unstructured user-created data for litigation holds and more.

Early case assessment. Our ECA tools help our clients to gain a better understanding of the challenges and weaknesses in their case with an early case assessment that they can use to formulate a stronger strategy. Our tools include data deduplication, near duplication, email threading, bulk tagging/coding, extraction of metadata and text, and culling and filtering data by keywords, dates, people etc. Using our ECA tools, Reveal can save the customer time, effort and significantly reduces costs.

Processing. InControl streamlines discovery and helps litigation teams process all the data and evidence without having to move between multiple systems, speeding up workflows and reducing risk. Our specialists oversee processing of a case from start to finish, using the right technology and framework for its specific needs.

InControl has everything needed to categorise and sort data to easily identify the most important information in the case. This presents smarter insights so legal teams can see the overarching facts in the case and create the strategy that leads to success. The InControl Processing engine integrates seamlessly with the InControl review platform, allowing clients to use one system for all of their data.

Accelerated Review. We recognise that corporate legal departments are under increasing pressure to control costs and to achieve greater cost predictability which is no easy task in the era of big data. Data volumes have exploded and document review, traditionally one of the largest percentages of a litigation budget, can seem insurmountable regardless of resource allocation. Given these challenges, we have integrated Technology Assisted Review (TAR) and data visualisation functionality within the InControl eDiscovery Platform to accelerate the document review process. This advance technology uses Advanced Text Analytics and Continuous Active Learning to determine responsive and non-responsive documents sets.

InControl Accelerated Review (IAR) and data visualisation uses machine learning to find relevant documents based on input provided by human users. By a user reviewing and tagging a small portion of the data set IAR uses document tags to train a ranking algorithm that orders the documents from most to least likely to be relevant. Unlike traditional linear review, Accelerated Review allows the managing attorney to determine that a review is complete without requiring ‘eyes on’ review of every document. The managing attorney has the ability to monitor the decisions being made by reviewers in near real-time to more effectively control a pool of document reviewers. They can quickly identify issues and refine the review protocol in the early stages, before costly re-review becomes necessary. Using IAR, we offer real-time reporting which shows the accuracy of the trained model on-the-fly.

IAR provides lawyers with the ability to eliminate human review for large percentages of a document collection – often as much as 90%, potentially shaving millions off a company’s legal spend.

Online review. The InControl software is flexible, reliable and customisable with a user friendly interface. It is cross browser compatible meaning that InControl can be accessed and used in the office, or at home on an iPad using any internet browser. There are no add-ons or installs required, it just works! This mobility allows teams to maximise their time and provides access to the information whenever and wherever it is needed. Our review platform helps to keep our clients InControl of the entire document review process. Users experience day one productivity with minimal training. InControl has full production capabilities including redactions and stamping.

Transcript Manager. InControl has a fully-integrated Transcript tool. Once a transcript is uploaded as a text file, a reviewer has the ability to search by page and line, highlight and tag key portions of the transcript, and hyperlink exhibits or other documents within the case.

Owned/Supplied by :	Reveal Data Corporation
Used by :	Navigant

8.2.30 Index Engines

It is important to select a identification, collection and preserving platform that supports backup tapes. Backup tapes have been neglected as a source of ESI in the past, however they have quickly become a reliable and convenient source of ESI. Backup tapes are a point in time snapshot of user data and emails. It is far more convenient to collect data from tape than from a live production environment.

Index Engines provides a cost-effective and comprehensive, electronic discovery and early data assessment solution for backup tapes. Index Engines solutions provide the following:

ACCESS: Delivers a single unified view into all data sources, from forensic images and networks to legacy backup types. No other product can get access to all this data allowing de-duplication and queries to be performed across a wide data set, simplifying the culling process and ensuring all ESI is forensically sound and reliable.

AUTOMATION: Index Engines has automated the workflow, accelerating the process of identifying and collecting ESI. Automated, stored queries can run on a scheduled basis to automatically find and extract ESI from any source. Automation minimizes manpower requirements and reduces the time and cost to collect data.

EFFICIENCY: Process large volumes of data quickly, from networks to backup tapes. A unique patented architecture processes speeds of 1TB per hour using a single node. Large volumes of data can be quickly processed and culled in order to meet even the tightest deadlines. A single Index Engine can process up to 70TB of data from any source.

FLEXIBILITY: Deployment options allow access to Index Engines technology through onsite deployment to manage the ESI collection process in house. Additionally, a cloud service is available for backup tapes so they can be indexed and searched using a web-based interface, where you can tag relevant ESI for extraction.

EASE OF USE: Most important is to have an interface that is automated and easy to use. Index Engines automatically eliminates unnecessary files and emails using powerful deNISTing and de-duplication algorithms. The intuitive interface allows one click culling to eliminate full email domains and file locations, allowing for rapid filtering of the content.

LOWERING COST: Index Engines provides a cost effective platform for delivering access to data on networks, forensic images and even backup tapes. Because of the efficiency built into the platform the predictable costs are lower than other solutions and are in line with your client's budget. Additionally, Index Engines allows you to consolidate multiple tools into a single unified identification and collection platform that simplifies the project and delivers more reliable results.

Owned/Supplied by :	Index Engines
Used by :	CDS, Deloitte, Integreon, Millnet.

8.2.31 Integreon Tools

Software Information

Integreon maintains strong partnerships with the world's leading technology developers for hosted review and analytics, including kCura's Relativity, Recommind (now OpenText), and Venio Systems. These partnerships provide access to the review experience and multilingual expertise of Integreon combined with the technical capabilities of each partner. Clients gain a best-in-class solution for their first-level document review, which can bring together analytics and technology-assisted review with Integreon's renowned Lean Six-Sigma processes and workflows.

Data Reduction and ECA Software:

Integreon's tools include **IPRO Allegro**, **Mindseye TunnelVision**, and **VenioOne** and enable testing different parameters for data domains, email senders and recipients, file extensions and other metadata fields, making data easier to visualize and the process for defensible reduction more manageable.

The easy-to-use web interfaces also allow clients to test date ranges, key terms and derivatives; select de-duplication options; and set file-type and domain exclusions to ensure relevant documents are sent into subsequent full processing and review.

Processing and Production Software:

Integreon's technologies for full processing include **IPRO's eCapture**, **Mindseye's TunnelVision**, and **VenioOne** among others. Integreon's discovery consultants also work with each client to select the tools and technologies that will best meet their specific needs and case requirements.

Hosted Review Software:

Integreon's technologies for hosted review include:

- **Relativity from kCura:** Integreon has been a partner with kCura, developers of Relativity e-discovery software, since 2010. Integreon is a Relativity Premium Hosting Partner.

Integreon offers clients the choice of (1) using the Relativity review platform as an a la carte hosted service, (2) as a managed service, or (3) as an integrated document review process that combines the review platform with managed review services. The company also provides exceptional support from a team of Relativity Certified Administrators.

- **Recommind:** Integreon and Recommind (now OpenText) have been working together for three years, and more recently formed an alliance partnership as a mutual commitment to their clients in support of review engagements in the UK and Canada.

The partnership provides clients access to the review experience and multilingual expertise of Integreon combined with the technical capabilities of Recommind. Clients also gain a best-in-class solution for their first-level document review, bringing together Recommind's innovative analytics and predictive coding technology and Integreon's renowned Lean Six-Sigma processes and workflows.

- **VenioOne:** Integreon and Venio Systems recently announced a partnership in which Integreon has become a "trusted partner" for offering and support of the VenioOne and Venio On-Demand platforms. Through this technology partnership, Integreon offer Venio as an all-in-one web-based e-Discovery solution that helps law firms and corporations to decrease costs, lower risks, increase reliability and improve management of litigation.

Chapter 8 – Supplier & Software Details

Owned/Supplied by :	Various & Integreon
Used by :	Integreon

8.2.32 Intella Suite (Vound Software)

With Intella’s unique Cluster Map technology, relationships and timelines between custodians and Electronically Stored Information (ESI) are instantly visualized, so you can quickly drill down through terabytes of information to find the most pertinent of evidence.

This innovative approach to digital forensic search minimizes the need for a broad array of investigators and significantly cuts the time and costs organizations normally need to carry out digital investigations, audit requests and e-discovery.

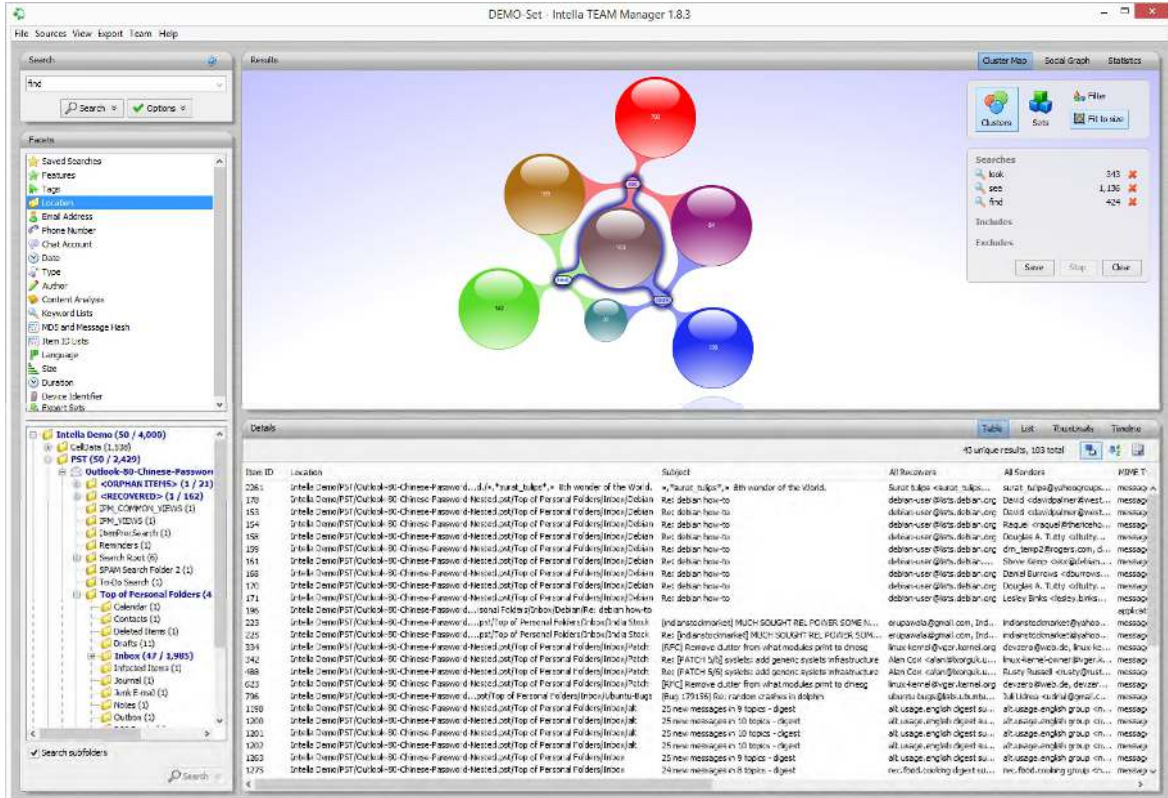

Cluster map view

Chapter 8 – Supplier & Software Details

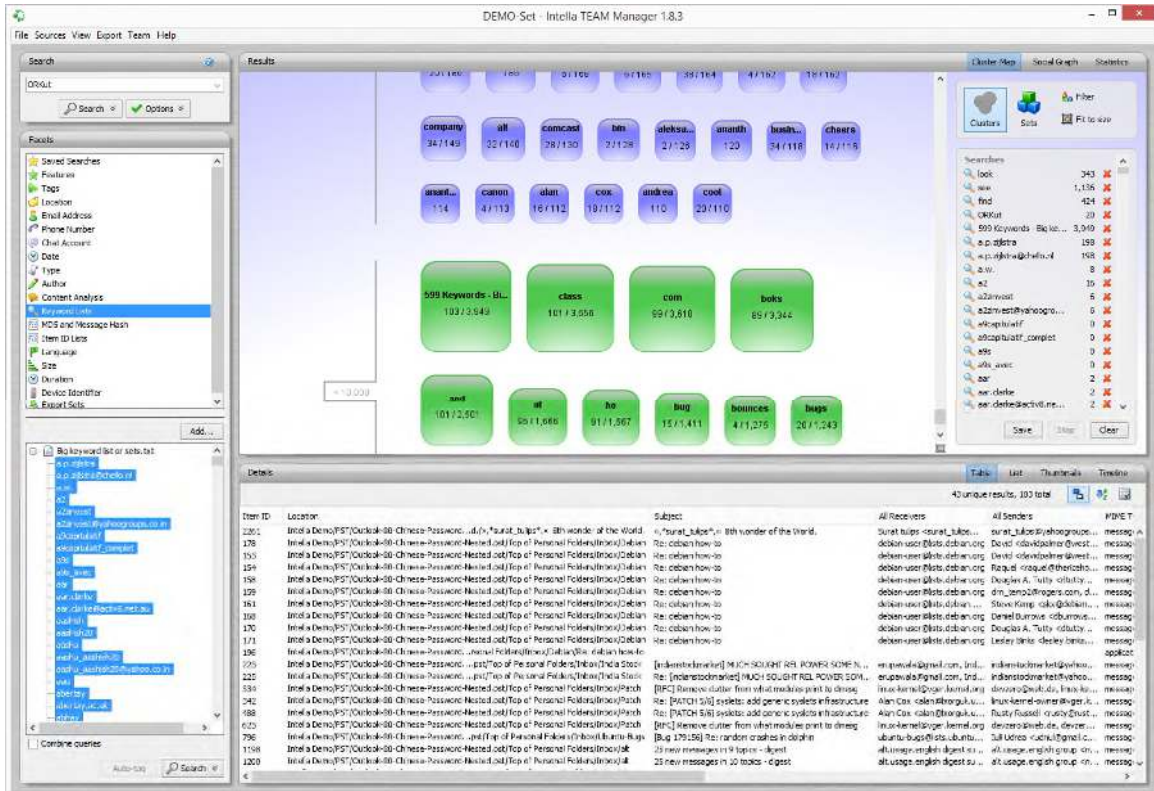

Sets view

Intella has an easy-to-use interface allowing high quality results and review capabilities with surprising ease.

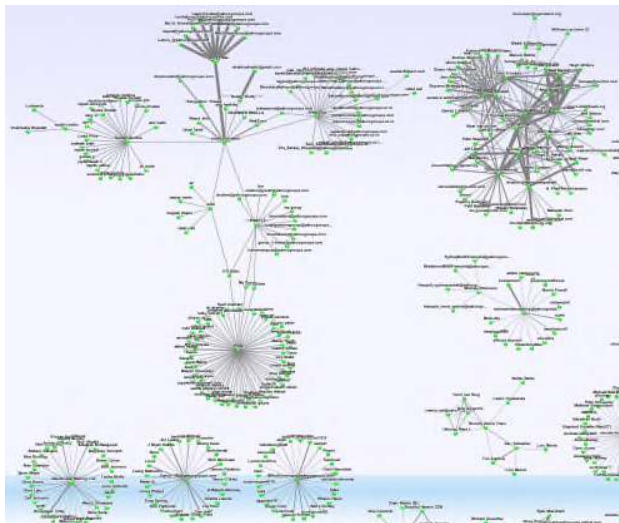

Visual mapping of custodians communication networks

Chapter 8 – Supplier & Software Details

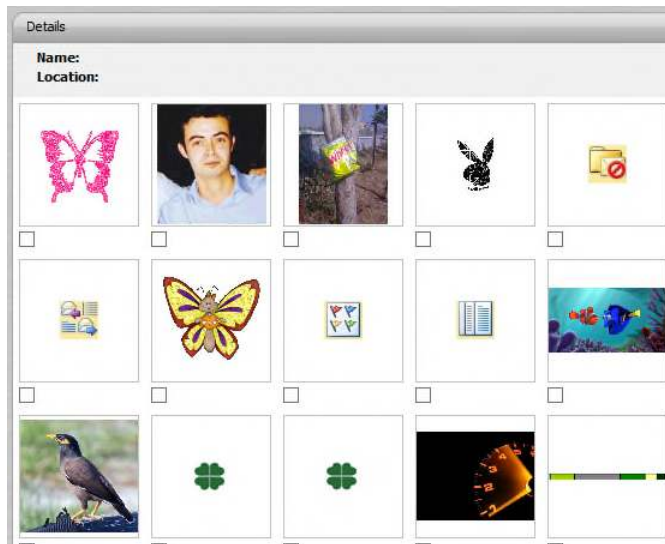

Extraction and display of all images from the ESI.

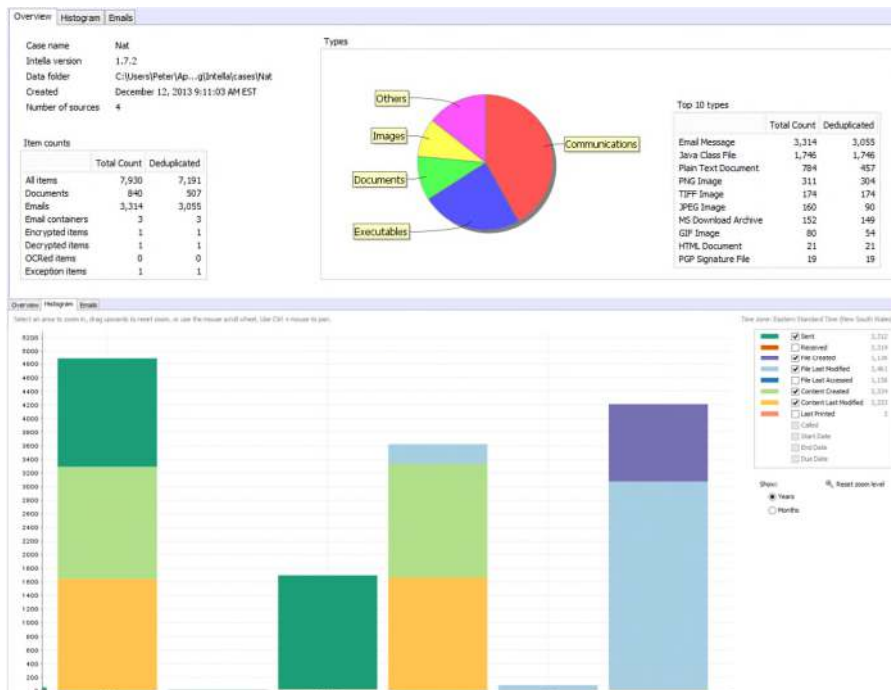

Statistical overview of case and ESI.

Chapter 8 – Supplier & Software Details

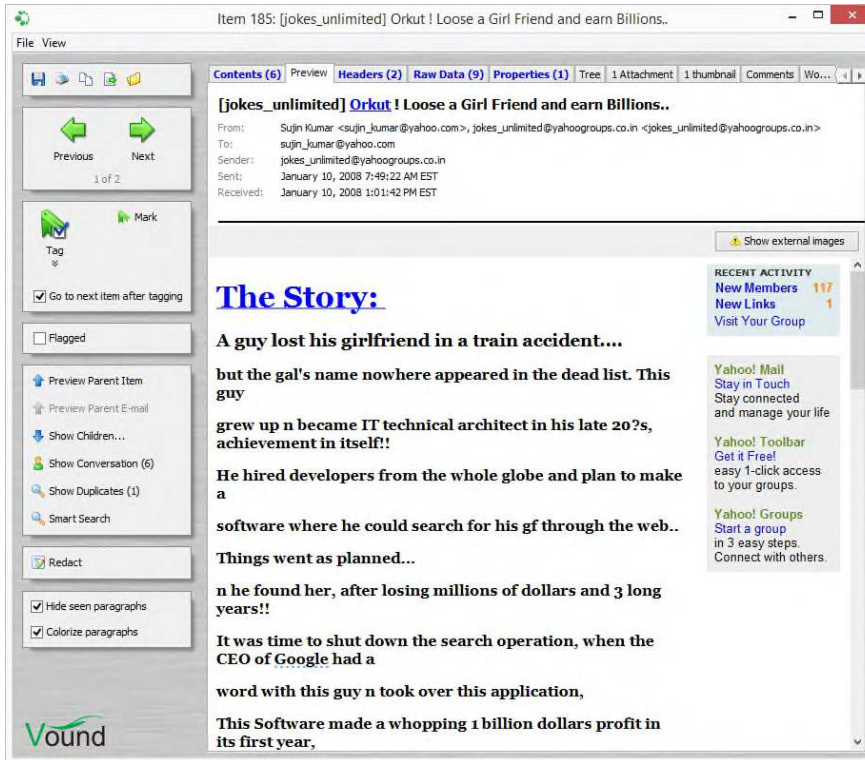

Easy to use review interface for viewing search results

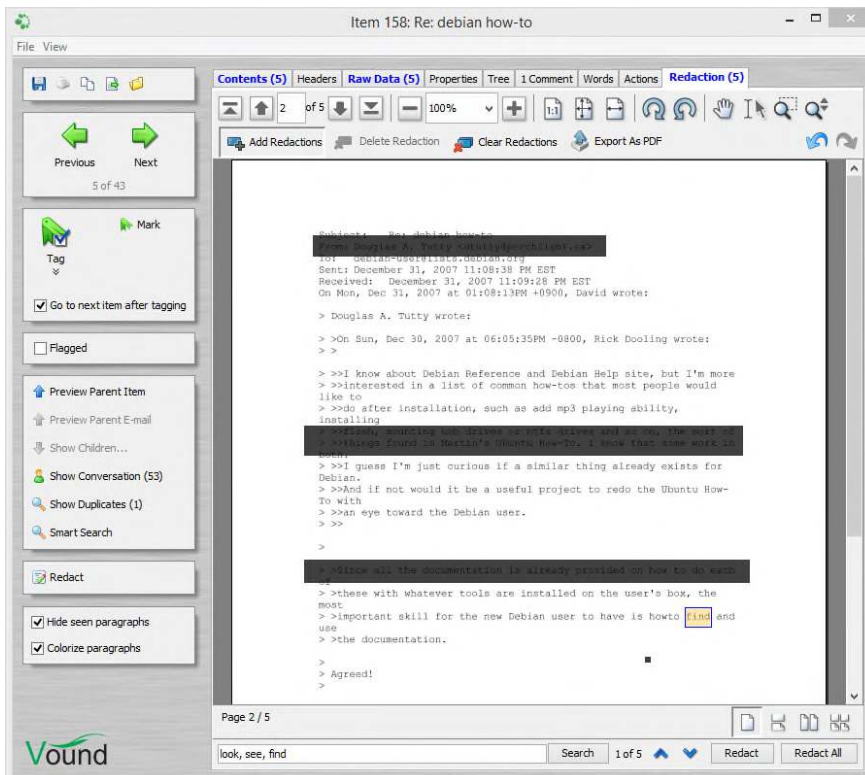

Redaction editor

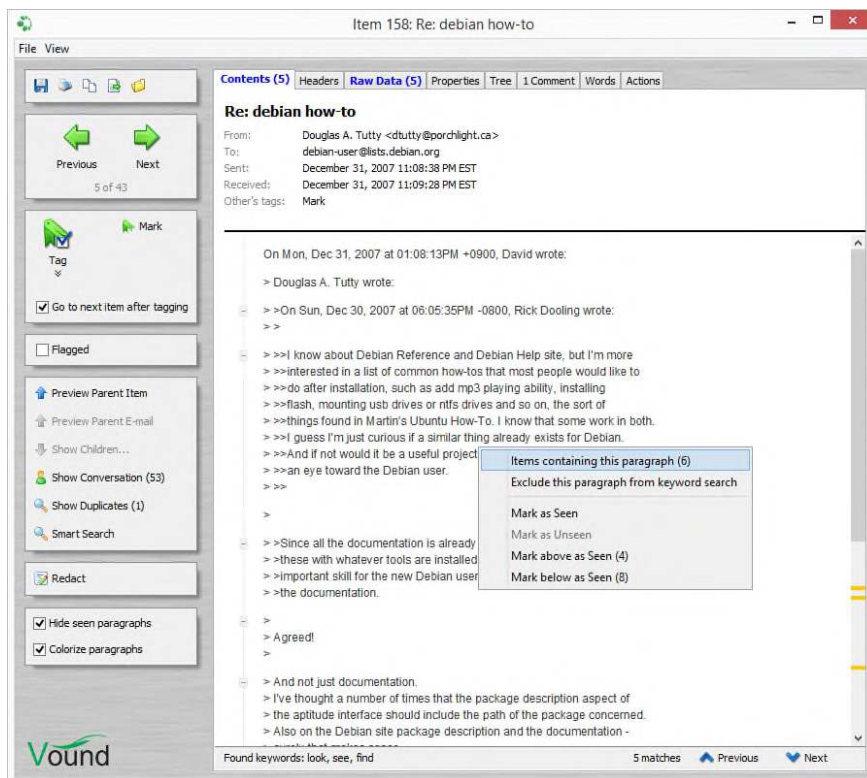

Paragraph Analysis for identifying identical paragraphs

Intella Connect and Connect Plus

Intella® Connect and Connect Plus are web-enabled document review platforms allowing multiple reviewers to simultaneously work on the same case without software installation or complex network and system configurations. Intella Connect allows up to 4 active cases and Connect Plus extends this limit to 10 active cases.

Intella Connect and Connect Plus are remarkably easy to use and require little-to-no-training for users, making it ideal for:

1. Consultants who allow clients **remote access to review a case**
2. Organizations with **multiple or remote locations** who investigate and review the same case
3. Multiple departments and review teams that need to **jointly review the same case**

Using a web browser over HTTP or HTTPS, Intella Connect and Connect Plus are managed and installed on a workstation in your environment. You control whether Intella Connect or Connect Plus are used only on the local network or hosted on the cloud for access by remote users.

The single Intella Connect or Connect Plus installer file configures all necessary components needed to manage and share a case directly with your reviewers. Reviewers do not need a dongle and only require a compatible web browser to review a case and data; no client installation or download is required.

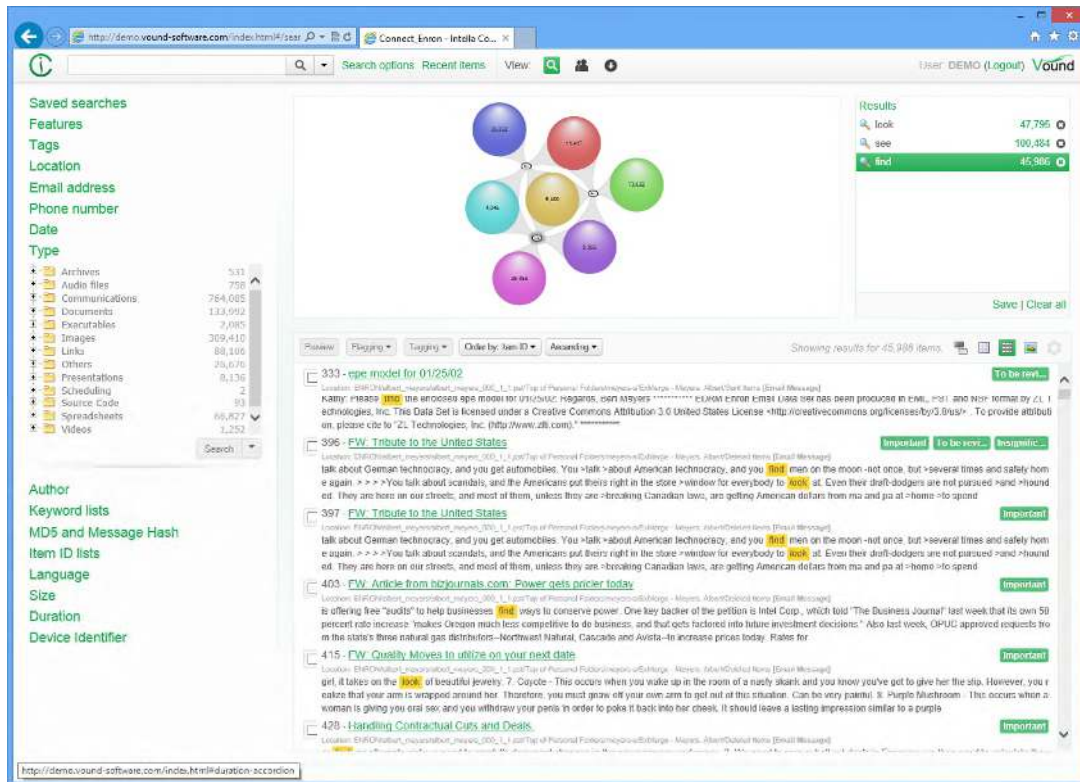

INTELLA TEAM

Intella Team enables multiple individuals (reviewers, investigators, paralegals etc.) to independently and simultaneously review Electronically Stored Information (ESI) / digital evidence.

With advanced export and sharing features, Intella Team makes it easy for analysts and reviewers to collaborate on investigations within a purpose-built platform.

Intella’s robust indexing engine delivers market-leading speeds for faster processing of data sets. Together with a user interface which is remarkably easy-to-use and multiple search visualization options including our unique Cluster Map, users are able to quickly drill down through volumes of unstructured data to find the most pertinent evidence with ease.

Intella® TEAM is comprised of two components:

Intella TEAM Manager for one case manager

- Index & prepare case data or evidence
- Share case data between team members
- Combine, review and approve work of team members

Intella TEAM Reviewers for up to 3 team members

- Independently search, filter, bookmark, tag, and comment on case data
- Transfer work back to the TEAM Manager for review and approval.

INTELLA PRO

Intella Pro licenses are unlimited in case data sizes, making it ideal for corporate investigators, professional service firms and consultants who work on cases with large volumes of Electronically Stored Information (ESI) / digital evidence.

Intella’s robust indexing engine delivers market-leading speeds for faster processing of data sets. Together with a user interface which is remarkably easy-to-use and

multiple search visualization options including Intella’s unique Cluster Map, users are able to quickly drill down through volumes of unstructured data to find the most pertinent evidence with ease.

INTELLA 250

Intella 250 is a powerful yet intuitive digital investigation tool for single users working on cases with data sizes up to 250 GB.

Intella’s robust indexing engine delivers market-leading speeds for faster ESI / digital evidence processing. Together with a user interface which is remarkably easy-to-use and multiple search visualization options including Intella’s unique Cluster Map, users are able to quickly drill down through volumes of unstructured data to find the most pertinent evidence with ease.

INTELLA 100

Intella 100 is a powerful yet intuitive digital investigation tool for single users working on cases with data sizes up to 100 GB.

Intella’s robust indexing engine delivers market-leading speeds for faster ESI / digital evidence processing. Together with a user interface which is remarkably easy-to-use and multiple search visualization options including Intella’s unique Cluster Map, users are able to quickly drill down through volumes of unstructured data to find the most pertinent evidence with ease.

INTELLA 10

Intella 10 is a powerful yet intuitive digital investigation tool for single users working on cases with data sizes up to 10 GB.

Intella’s robust indexing engine delivers market-leading speeds for faster ESI / digital evidence processing. Together with a user interface which is remarkably easy-to-use and multiple search visualization options including Intella’s unique Cluster Map, users are able to quickly drill down through volumes of unstructured data to find the most pertinent evidence with ease.

Owned/Supplied by :	Vound Software
Used by :	7Safe, IT Group Ltd, Stroz Friedberg

8.2.33 Intelligent Voice®

High speed audio and video analysis and review underpinned by:

- Ultra-fast speech to text processing – using NVidia® GPU cards, server or cloud based.
- Topics of Interest – extracted via a proprietary technique and automatically surfaced.
- Hyperphonic Searching – combining the best of transcribed text, word probability lattice and phoneme-based search to offer the widest possible range of searches across a dataset.
- Biometric Voiceprint Searching – independent of any metadata or transcribed text.
- Lexical and Acoustic Model Tuning
- The Audio Discovery Reference Model© framework:

The Audio Discovery Reference Model

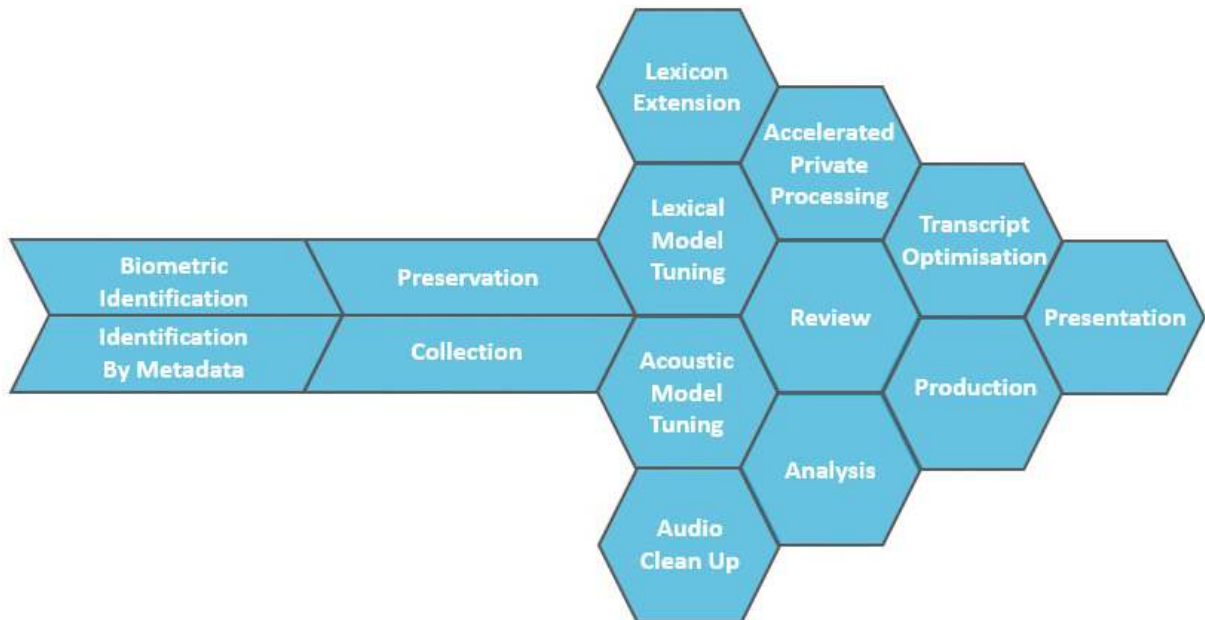

Copyright Intelligent Voice Limited 2017 / www.intelligentvoice.com

Biometric Identification

With audio collection metadata, Caller ID is often withheld, and where one is identified, it may be based on a phone line being assigned to them rather than them actually being on the call. Biometric Voiceprint Search enables recordings which are likely to contain a particular speaker to be identified and collected.

Lexicon Extension

Any of the available lexicons can have additional words, phrases and acronyms added directly to them. As many distinct lexicons as desired can be maintained, e.g. Financial Services versus Pharmaceuticals; Interbank Lending versus Foreign Exchange Swaps.

Model Tuning

If text directly related to the matter is available, such as email or IM, this can be used to tune the lexical model to be used. Any word or acronym from any of the documents within the corpus which is not already in the lexicon is automatically added to it. Words which tend to occur together and/or more often within the documents will increase the probability of Intelligent Voice correctly transcribing them together when audio is processed using the model.

It is also possible to create a custom acoustic model for a particular matter with as little as fifty hours of speech and matching transcripts.

Audio Clean Up

In addition to any manual techniques which may have been applied to the audio as a pre-processing step, Intelligent Voice® applies its own noise reduction techniques to optimise the automatic speech recognition.

Accelerated Private Processing

Intelligent Voice's open source software stack enables fully private processing, whether on air-gapped physical servers or secure private cloud instances. No need for data to leave the jurisdiction, company or even building.

Intelligent Voice's Neural Networking and machine learning provides greater accuracy in difficult environments such as noisy offices or open trade turrets. It also allows the system to "guess" phrases that were traditionally considered to be "out-of-vocabulary".

The fastest commercially available Speech to Text processing enables rapid progression to the analysis and review stages.

Even with very low quality audio, valuable text data is obtained that reduces subsequent review time by up to 70%.

Intelligent Culling™

Some audio data may, for one reason or another, be unusable for review. It may be hang-ups, background noise, or speech that is inaudible due to interference. A Confidence Report is available across the entire dataset, highlighting those files that are most likely low-priority review items, and those which are mostly silence or unintelligible.

Topic Trails

A set of suggested topics of interest for the review data set can be viewed:

"north korea"

Automatic Topics for Radio

- Artificial intelligence ▾
- Intercontinental ballistic missile ▾
- International Criminal Court ▾
- Chief operating officer ▾
- North Korean defectors ▾
- Air traffic controller ▾
- International community ▾
- President of the united states ▾
- Director of National Intelligence ▾
- Charlottesville, Virginia ▾
- Israeli Defence Forces ▾
- Advanced Placement exams ▾
- United States government ▾
- Defense Intelligence Agency ▾
- World Table Tennis Championships ▾
- Comprehensive Sex Education ▾
- Social Security Numbers ▾
- Classified information ▾
- Israeli Prime Minister ▾
- National Security Council ▾

Selecting any given topic will display the audio or video file or files in which that topic occurs, and also display the topics of interest around each of those files:



Any of the topics displayed around the audio or video files can in turn be selected, in turn showing the audio or video file or files in which that topic occurs, and the topics of interest for these files. As such, not only can this feature surface speech within the audio that a reviewer might never have thought to search for, it can also provide a rapid route into progressively more interesting terms within the data set, e.g. from “Last Ditch” to “Liquidity” to “Nationalisation”.

The list of topics will also automatically regenerate for any search terms run and for any filtering by date and time or custodians, suggesting topics of interest within the results set.

Hyperphonic™ Search

Intelligent Voice® combines the best of transcribed text, word probability lattice and phoneme-based search to offer the widest possible range of searches across a dataset.

Speaker Separation & Search

Using advanced biometric techniques, Intelligent Voice® can show who is speaking at different points in the call. This biometric information can be used to verify phone record metadata, and also to search for a particular custodian using their biometric voiceprint.

SmartTranscript™ Review Player

In addition to standard play and pause and horizontal time bar features, and a video screen if video rather than audio is being reviewed, the SmartTranscript™ Review Player also contains suggested topics of interest for the audio or video, which can be used to jump to the part or parts of the audio or video where that term occurs:

The screenshot shows a web browser window with the URL <https://www.gputechconf.eu/On-Demand/>. On the left, there is a 'JUMPTO™ TOPICS' sidebar with a scrollable list of topics, each with a number of results: High Performance Computing (2, 3), Artificial Intelligence (2, 3, 4, 5, 6), Computing Technology (2), Sensory Information (2), Autonomous Vehicle (2), Particle Physics (2), Exponential Growth (2), Speech Recognition (2, 3, 4, 5, 6), Computing Platform (2, 3, 4, 5, 6), and Image Recognition (2, 3, 4, 5, 6). The main area displays a video player for 'GTC Europe 2016 - Keynote'. The video thumbnail features a green abstract graphic with a red play button. Below the video, the text reads 'GTC EUROPE OPENING KEYNOTE 2016' and 'Brought to you by Intelligent Voice®'. The video description includes 'Published on Sep 29, 2016' and 'Jen-Hsun Huang, CEO and Co-founder of NVIDIA speaks about the future of Deep Learning, Artificial Intelligence and Autonomous Vehicles at Europe's first GPU Technology Conference.'

A searchable, navigable speaker separated transcript text, whereby clicking on any word within the transcript immediately jumps to that point in the audio or video, is also included.

Redaction

Audio and Video files can be redacted by highlighting the text and selecting the reason for doing so. Even if the text has been mis-transcribed the word position is accurate to the millisecond, so the system can create a perfectly redacted audio / video file, with a redacted transcript.

Production & Integration

A high-quality transcript can be interfaced into an eDiscovery system so that voice can be used alongside other text related to the matter such as email or IM chats for fast review.

In addition to the options for ingestion/production detailed above – Text, Email, Dat and Standalone SmartTranscript™ Review Player – Intelligent Voice® also offers a fully featured API to allow deeper integration with current platforms, as well as additional export options of JSON and XML.

Relativity Integration

As well as a traditional “workflow” route using pre-culled data in a .DAT file to upload into Relativity, Intelligent Voice now offers a Relativity plugin, so that audio data held in Relativity can be converted to text natively

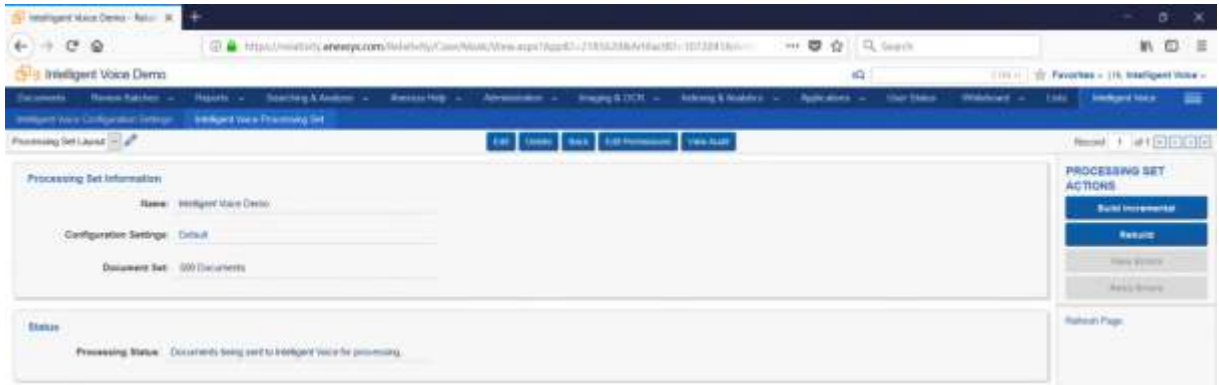

Deployment

Intelligent Voice is deployed as an appliance – a server with all the necessary software already installed – and as such is simple to implement, and platform agnostic. Deployment can be on premise or in the cloud (e.g. AWS or Azure).

Training is measured in hours not days. Depending on the user base, no formal training may be required at all.

Owned/Supplied By:	Intelligent Voice Limited
Used By:	Many of the world’s leading eDiscovery companies including Anexsys, DTI / Epiq and Ankura as well as Government departments and regulators such as the US Department of Justice Civil Anti-Trust Division

8.2.34 Inventus software suite

Inventus leverages a variety of technology solutions to reduce the overall cost of litigation and to provide budget predictability on projects. Clients have access to our comprehensive suite of technology and analytics tools which include both internally developed solutions and partner technology.

Spotlight - <https://www.inventus.com/spotlight>

Relativity - <https://www.relativity.com/customers/inventus-platform/>

Venio - https://www.veniosystems.com/trusted_clients/inventus/

Spotlight: <https://www.uk.inventus.com/spotlight>

Spotlight is a business data analytics dashboard that provides full visibility into all of your key metrics including data spend, ROI and reviewer statistics. Users have immediate access to any structured data set, such as e-billing, data volume or matter detail. Spotlight provides you with fully customizable and intuitive dashboards to assist in managing department functions, giving you valuable information to improve the decision making process.

Key Features:

- Instantly see key metrics, volumes and benchmarks on your own data in real-time. In addition to your own data, you now have the ability to measure and quantify outside counsel efficiency.
- Live access to all the key metrics in a document review gives Spotlight users the ability to take control over the costly review process. In addition, by mapping data visually, Spotlight can also help identify gaps in data sets based on chronology or help spot missing custodian data.
- Data is presented in fully customizable charts and graphs, preparation of budgets, benchmarks and executive level presentations now takes only minutes.

Owned/Supplied By:	Inventus
Used By:	Inventus

8.2.36 KLDiscovery Software Suite



Nebula is an end-to-end eDiscovery solution that facilitates smarter ways to cull, process, review and manage documents while creating substantial time and cost savings. Now available in the cloud, Nebula gives you all the versatility you need for processing, review, analysis and production of your data.

Designed with the user experience in mind, Nebula offers a more modern and user-friendly approach than other review tools that can be overwhelming to administer and navigate. The web-based application is also accessible from all modern browsers. Advanced processing capabilities streamline review with the assistance of email threading, optical character recognition and near-duplicate analytics. Native review options also give you the ability to eliminate the time-intensive conversion of data into TIFF images, including CAD drawings.

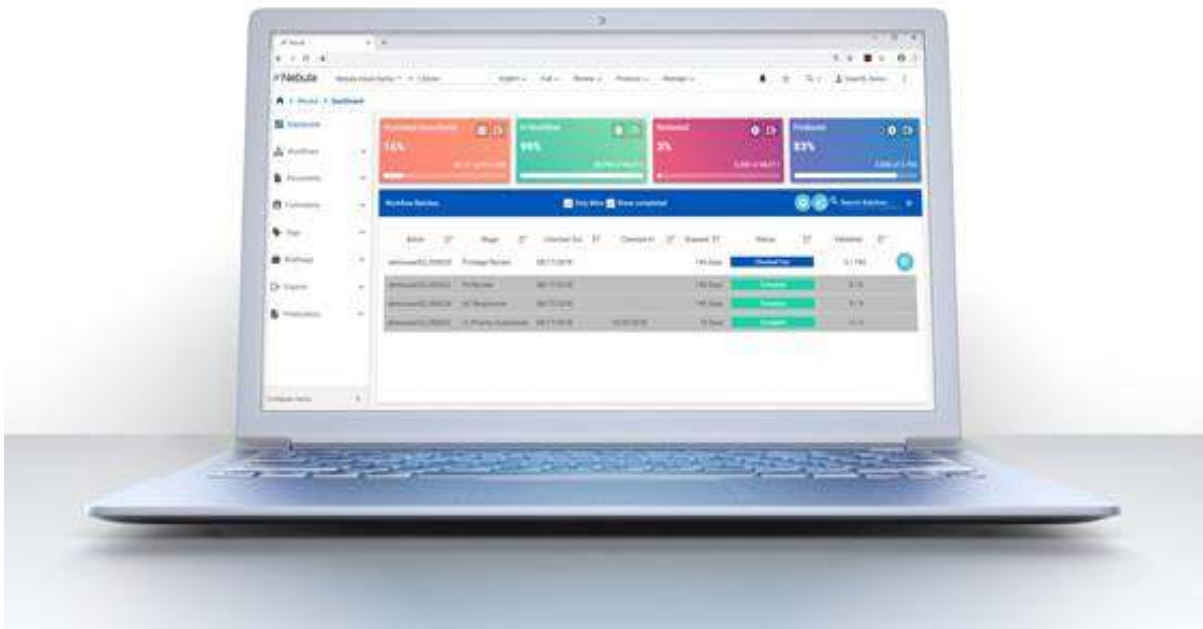

Nebula can be hosted within the Microsoft Azure cloud, offering scalability and rapid deployment to meet your unique needs. Azure provides a comprehensive set of security capabilities, including role-based access, virtual environments, network access controls and data encryption. In international matters, data can be processed and hosted in one country and accessed in another. Alternatively, Nebula can be hosted in our state-of-the-art ISO 27001-certified data centres that are designed to provide the highest levels of performance, data protection and fault tolerance. Regardless of your preference, we take care of the infrastructure, so you can focus on your case.

Nebula features KLDiscovery's suite of unique and proprietary applications:



Predictive Coding

Award-winning, patented technology that leverages human expertise to drive results. Predictive Coding with Continuous Active Learning combines user decisions and random sampling to immediately and continuously prioritize important documents for review. Quality Control and Sampling monitors the effectiveness of document categorizations to arrive at the necessary confidence levels to ensure defensibility.



A/V Suite

Winner of a Relativity Innovation Award for Best Service Provider Solution and People's Choice, A/V Suite simplifies the review of multimedia files. Visualise audio files and have total playback control. Easily redact and produce audio files – something no other review platform can provide.



Workflow

Automate the routing and distribution of documents to streamline document review and maximise accuracy and defensibility.



AutoRedaction

Protect sensitive information and streamline the redaction process with an automated approach. Greatly reduce the burden of redacting documents by automatically finding and redacting personally identifiable information, privileged content and other sensitive information.



Native Spreadsheet Redaction

Redact content from Microsoft Excel and other spreadsheet files without the need to convert to TIFF. Options for redactions include removal of rows, columns, worksheets, formulas, cells and standard text redactions. Pristine copies of the original files always remain intact.



KLD Analytics

With Email threading and Near-duplicates text analytics, you can identify the most content-inclusive messages to avoid redundant review and group similar records for a quicker review.



Measuring roughly the size of a briefcase, NPC is a portable tool that allows powerful processing, filtering and analysis without the need to transfer data outside the company or across borders.

Conduct covert, full-scale investigative work with NPC without removing data from an organisation or country. Highly sensitive data stays secure and no connection outside the company firewall is required. Remote support requires manual authorisation before KLDISCOVERY has access to the environment.

IMPRESSIVE PERFORMANCE

Powerful enough to accommodate processing, filtering and review on-site. NPC can host Terabytes of active case data for dozens of concurrent users.

PORTABLE & COMPACT

Our cutting-edge mobile technology enables NPC to be deployed anywhere in the world, including your office. NPC can be stowed within a Pelican™ case for convenient transportation.



GLOBAL CONSIDERATIONS

Our forensics experts ensure all data is collected and processed in a defensible manner according to country-specific protocols. NPC devices are even constructed on multiple continents to ensure compliance.

POWERED BY NEBULA

A powerful combination of capability and simplicity, Nebula brings a fresh perspective to established technology with improved flexibility and control. Enabling smarter ways to analyse, process, review, and manage large data sets.

NPC is small enough to carry on commercial flights, allowing for quick and flexible deployment. Our on-site solution is backed by the expertise of KLDISCOVERY's forensic investigators, eDiscovery consultants and case managers who are familiar with local laws, languages and cultural considerations.

Designed to be a self-sufficient, full featured processing engine through review and productions, NPC supports multiple concurrent reviews as well as high-volume processing requirements. NPC offers a repository and matter-specific review platform where data can go to the repository for preservation/searching/ECA and also directly to a designated review database.



We have incorporated our proprietary predictive coding functionality and powerful analytical tools into our Relativity offering to ensure all our clients' specific needs are addressed. All our Relativity projects are supported by a dedicated team of experts with the necessary experience and a range of Relativity certifications to help you get the most from Relativity. We also offer Relativity as an onsite solution.

Relativity features KLDDiscovery's full suite of unique and proprietary applications:



Predictive Coding

Award-winning, patented technology that leverages human expertise to drive results. Predictive Coding with Continuous Active Learning combines user decisions and random sampling to immediately and continuously prioritize important documents for review. Quality Control and Sampling monitors the effectiveness of document categorizations to arrive at the necessary confidence levels to ensure defensibility.



A/V Suite

Winner of a Relativity Innovation Award for Best Service Provider Solution and People's Choice, A/V Suite simplifies the review of multimedia files. Visualise audio files and have total playback control. Easily redact and produce audio files – something no other review platform can provide.



Workflow

Automate the routing and distribution of documents to streamline document review and maximise accuracy and defensibility.



AutoRedaction

Protect sensitive information and streamline the redaction process with an automated approach. Greatly reduce the burden of redacting documents by automatically finding and redacting personally identifiable information, privileged content and other sensitive information in a Relativity workspace.



Native Spreadsheet Redaction

Redact content from Microsoft Excel and other spreadsheet files without the need to convert to TIFF. Options for redactions include removal of rows, columns, worksheets, formulas, cells and standard text redactions. Pristine copies of the original files always remain intact.



KLD Analytics

With Email threading and Near-duplicates text analytics, you can identify the most content-inclusive messages to avoid redundant review and group similar records for a quicker review.



PrivLog Builder®

Utilise an integrated suite of tools with advanced functionality to effectively build privilege logs. With automated privilege log features, name standardisation and full compatibility with the most popular review platforms, you save time and produce remarkable results.

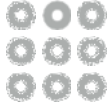

MultiMatter Management

Easily and defensibly reuse lawyer work product across matters, resolve coding inconsistencies in real time, and minimise the risk of inadvertent production of privileged and protected content.

EDR

EDR is a proprietary review platform built by KLDDiscovery and incorporating many of the groundbreaking KLD enhancements which have subsequently been built into Nebula and our version of Relativity. EDR has been built from the ground up by KLDDiscovery meaning that we have been able to custom develop it to meet our clients' requirements, and some of our clients have now been using it on projects for more than a decade. Whether utilising the industry's most powerful predictive coding technology, and automated workflow, EDR delivers powerful and accurate results through a simple and non-technical interface.

EDR enables you to utilise:

- Industry-leading predictive coding, utilizing a proprietary algorithm for Continuous Active Review. The major benefit of KLDDiscovery predictive coding is not only the advanced nature of its algorithm, but also the extent of its integration into our platforms and automated workflow. This enables true Continuous Active Learning; learning sessions run automatically every 4 hours, or a session can be initiated manually at any time.
- Automated workflow enables case managers to work with you at the outset of a project to set up a workflow which automatically batches documents to specific review teams. This works especially well with prioritisation from our predictive coding, automatically updating and batching priority documents to reviewers in real time.
- Language identification and in-platform machine translation without needing to remove data into a separate software tool. This enables you not only to identify documents in different languages but also to view the original document alongside the translated text.
- Phonetic search and review of audio files, enabling you to find relevant information even when it is hidden in audio content such as recorded voicemails or recorded microphone feeds.

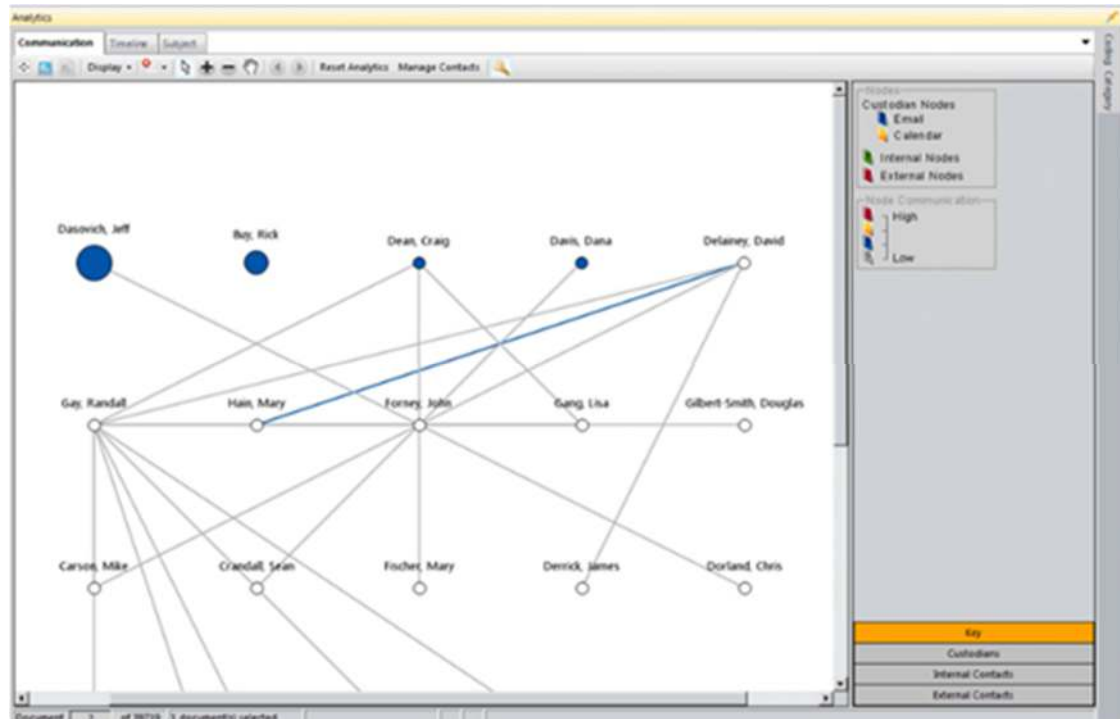

- Analytics including visual communication analysis (see above), email threading and near-duplicate identification and analysis included as standard.

Owned/Supplied by :	KLDDiscovery
Used by :	KLDDiscovery

8.2.37 KOFAX Capture

Kofax Capture automates and accelerates business processes by capturing all types of paper and electronic documents and forms, transforming them into accurate and actionable information, and delivering it all into your core business applications, processes and workflows. Whether your information is on paper or in electronic files, parked at a central office or scattered on desktops and remote offices throughout the world, Kofax Capture can help you handle it all.

Offering unmatched scalability, Kofax Capture is a powerful, enterprise ready, production level capture platform. It captures information from virtually any source: scanner, multi-function printer, print stream, email, fax, web service or folder. It automates capture driven processes at the perimeter of the organization or wherever documents are received, regardless of the location, source, language or type.

No matter what hardware or enterprise applications you choose now or in the future, you can count on Kofax Capture to ensure consistent document capture, indexing and validation of your important information.

Owned/Supplied by :	KOFAX
Used by :	Legastat

8.2.38 Law PreDiscovery

Law PreDiscovery software combines production-level imaging and electronic discovery processing in one powerful, easy-to-use application that also includes the following functionality;

- Load electronic documents and mail stores, scan paper documents, and import TIFF images and load files,
- Extract text and metadata for other database applications,
- Process e-documents, mail stores, file lists and Microsoft Outlook folders simultaneously,
- Perform de-duplication and culling to process and review only responsive data,
- Use enhanced filtering capabilities for faster, more effective searching and culling.

Owned/Supplied by :	CloudNine
Used by :	AlixPartners, A&M, Iris, Legastat, LINEAL, Navigant

8.2.39 Lighthouse Technology Solutions

Lighthouse Spectra

Spectra is Lighthouse’s powerful cloud-based, user-driven information retrieval, analysis and management platform for ediscovery and compliance teams. Spectra is ideal for internal investigations and smaller matters where in-house experts are self-sufficient and want access to industry-best tools and capabilities and expert resources available to support and supplement them, as needed. Combining Lighthouse’s innovative technology with the processing power of Nuix, the document review capabilities of Relativity, and the imaging finesse of Ipro, Spectra delivers a powerful, scalable, and user-friendly experience. Spectra is deployed in the cloud, providing a scalable, highly available, and secure environment for mission-critical operations.

Lighthouse SmartSeries

Lighthouse SmartSeries is a proprietary suite of technologies and customized workflows designed to reduce your overall eDiscovery cost, risk, and review time, while improving your review team’s consistency. They are optimized for Relativity so reviewing attorneys can work efficiently in a familiar environment. Now that’s smart.

ChatSmart

ChatSmart sets the SmartSeries apart with its unique ability to provide rapid, efficient, and complete review of chat data in many formats, from multiple sources. It combines unmatched innovation, and deep understanding of the particular challenges associated with chat messaging to deliver the only solution you will want to rely on for review of instant message, cell phone, and chat communications.

RedactSmart

RedactSmart enhances the SmartSeries by increasing the speed and consistency with which redactions are applied, using programmable pattern recognition to complete hundreds of redactions in minutes.

ReviewSmart

ReviewSmart rounds out the SmartSeries by providing the rapid and efficient disposition of duplicate documents that survive initial family-level deduplication. ReviewSmart analyses a user-defined data set, identifies all document-level duplicates within, and bundles them into unique groups, allowing a single document from each duplicate group to be reviewed and redacted with this coding propagated to its duplicates. Importantly, ReviewSmart can then analyze these duplicates and their families to identify and alert the user to coding inconsistencies that may require attention.

Owned/Supplied by :	Lighthouse
Used by :	Lighthouse

8.2.40 LitSavant Conformity Engine

The LitSavant Conformity Engine is a Relativity® application which enables Project Managers to design and implement validation rules and other logical processes which are then enforced during data entry.

This works by allowing the user to specify what they want the software to do and the conditions that need to be fulfilled in order for the software to do it.

Here are 5 easy examples illustrating how these rules can be used and why they are very useful in increasing accuracy and reducing costs:





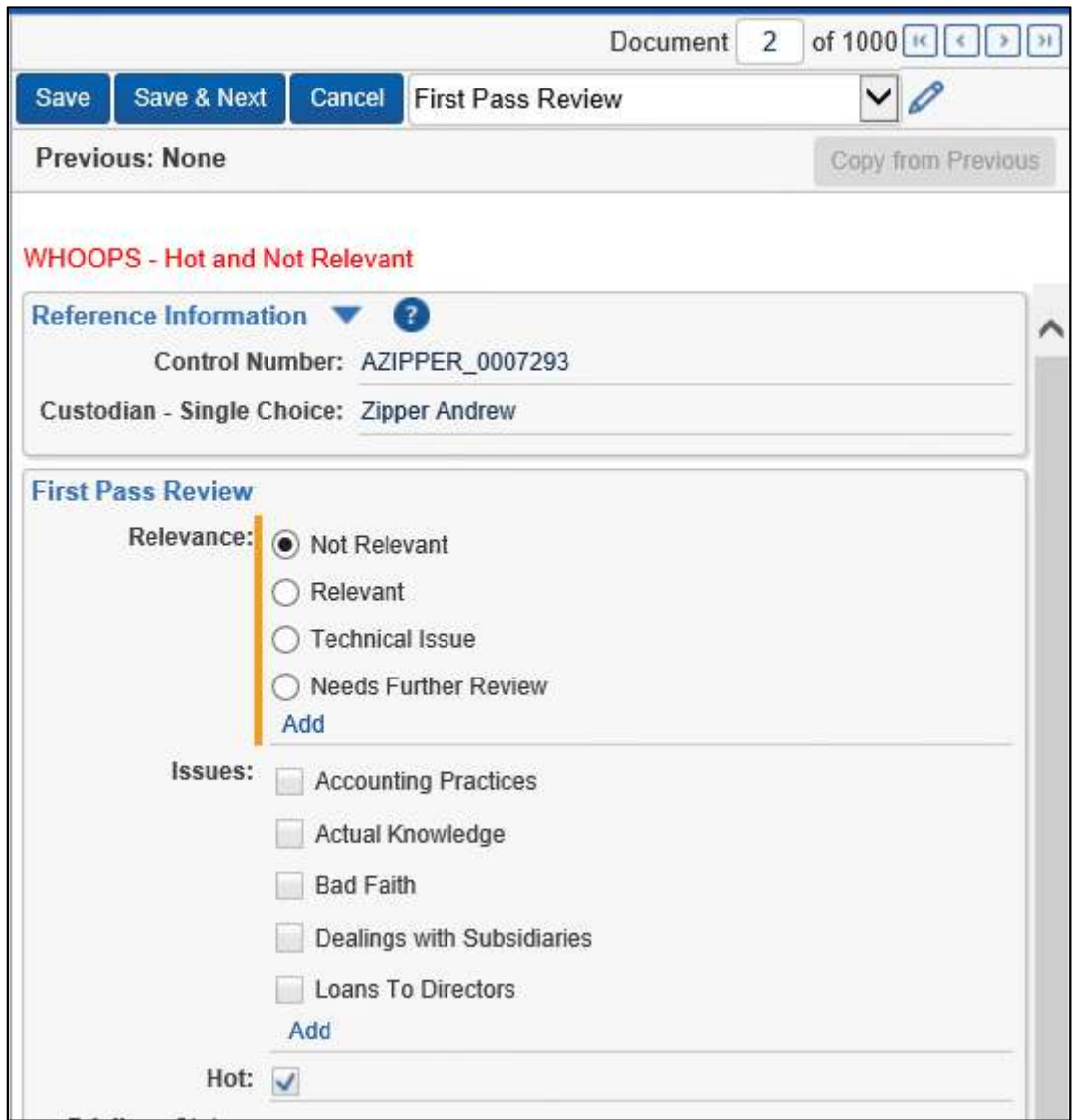

Example 1 – Alert the user when they get it wrong

This is the commonest scenario and results in an onscreen message when the user codes something in a way that doesn't meet predefined rules.



Example 2 – Log mistakes (when users get it wrong)

When a user makes a mistake (such as coding a document both “Hot” and also “Not Relevant” as per the example above), in addition to alerting them so that they correct the error, we can also log the mistake. The mistakes can then be analysed to identify recurring themes for corrective action etc.

New Mistake				
All Mistakes   				
0 Selected Item(s)				
#	<input type="checkbox"/> Name		Mistake Type	Mistake Made By
1	<input type="checkbox"/> MSTK1005	Edit	 Hot and Not Relevant	Dingle, Mark
2	<input type="checkbox"/> MSTK1002	Edit	 Missing Privilege Decision	Dingle, Mark
3	<input type="checkbox"/> MSTK1001	Edit	 Missing Issue	Dingle, Mark

Example 3 – Send an email when hot documents are found

This example is pretty self-explanatory - when a user identifies and codes a document as hot for the first time, the software can send a customised notification email to specified users. The email could include information about the user who tagged the document as hot, any comments that they made and any additional coding from the document.

Example 4 – Update the “Last Coded By” field

It’s not uncommon to want to know who reviewed a document during a particular review round. The software can update a “Coded By” field – saving the user from having to enter this information.

Example 5 – Update a “Family Privilege” field based on “Privilege” coding

Relativity propagation is a pretty blunt instrument in that the last coding decision on a family member is applied to all members of the family. If we want to know whether a family contains a privileged (or part privileged) document, standard Relativity propagation doesn’t really do the job.

Instead we can create a custom action to use “Intelligent” propagation. With this approach, users code the “Privilege Status” of each document and the software then updates a field for all members of each family based on that coding to indicate if they are members of a Privileged, Part Privileged or Not Privileged family.

Detail

The examples above illustrate the 5 functions that the software can perform as part of the coding process. These functions are:

- Show an onscreen message
- Create a new instance of an object
- Send an email
- Update a field
- Execute a Relativity script

One or more of these functions can be triggered when the specified conditions are met. Each of these functions is customisable and can be triggered by one or a combination of conditions. The conditions themselves are also fully customisable.

Whilst all of the examples relate to coding documents, these functions are available on all custom objects as well.

Each of the functions above could be created by a programmer in code and deployed via an Event Handler. The innovation in the LitSavant Conformity Engine is that Relativity’s standard interface is used to enter the rules – no programming knowledge is required and so the rules can be created, tested and deployed in minutes. And because the LitSavant Conformity Engine saves your rules into your Relativity

Chapter 8 – Supplier & Software Details

database when it is time to upgrade Relativity, you simply update the application as part of the upgrade process. If you were using Event Handlers you would need your programmers to manually rewrite and redeploy each of your Event Handlers in all of your databases.

The LitSavant Conformity Engine supports Relativity versions 8.0 and above (up to and including the current version). It is licenced on an annual basis and is available to anyone with their own Relativity environment.

Owned/Supplied by :	LitSavant
Used by :	Various UK, European and US organisations with their own Relativity environment

8.2.41 LegalCraft® Transcend

- Real-time transcription and evidence management software with integrated documents to enable searching, annotation, linking and generating reports on documents and transcripts using Transcend.
- Transcripts and documents accessible from iPad and transcripts from other mobile devices.
- Electronic Presentation of Evidence for viewing relevant material in the hearing room.
- Daily reporting, transcription, simultaneous and consecutive interpreting.
- Full deposition service using Transcend including in-house videography.

Owned/Supplied by :	Epiq
Used by :	Epiq

8.2.42 Magnum

Opus 2 Magnum is a secure web-based service that allows your team to access, annotate and collaborate on any legal content. Transcripts and documents, including hyperlinked pleadings/witness statements/skeleton arguments, web research or entire trial bundles are securely hosted within a simple interface which allows users to annotate and easily share comments with team members (barristers, solicitors, experts).

Opus 2 Magnum is an indispensable tool for trial preparation, providing significant cost benefits and giving your whole team access to one central workspace, from the office or remotely from any location with an internet connection, thereby eliminating the need to print and regularly update expensive hard copy sets.

Core Functionality

- Hosting of key documents/trial bundles and access online from anywhere
- Annotation of documents. Collaborate across the key materials with your wider team
- Hyperlinked documents: Transcripts to bundle references; Witness Statements to exhibits; Opening/ Closing Submissions to supporting material
- Create your own ‘Custom Bundles’ from the documents in the case
- Ability to capture and annotate your web research

Advanced Transcript Features

- Access your transcript from anywhere, using any device
- Annotate and share notes made in LiveNote securely with your team
- Listen to synchronized audio of the hearing
- Simple filtering system to review your team’s notes and annotations

Lawyers Choose Opus 2 Magnum

“The Opus 2 Magnum system enables instant access electronically to all the documents in the case. We’ve now reached the closing submissions stage where the system pays big dividends because the written closings can be researched, cut, pasted and finalised from the screen. I suspect that this is how all major litigation will, in the future, be conducted. I would say this is the most important development in trial work I’ve ever experienced in my time at the Bar.” - Lord Grabiner, QC, One Essex Court

Judges Choose Opus 2 Magnum

“[Opus 2 Magnum] enabled the trial to be concluded within the allotted timetable, and with the maximum efficiency. It also provided the inestimable advantage, from my perspective, of being able to access my notes made during trial, and the full galaxy of the trial bundles, from wherever I was and at whatever time of day (or night).” - Gloster J in her judgment on Berezovsky v Abramovich

Owned/Supplied by :	Opus 2 International
Used by :	Opus 2 International

8.2.43 MedBrief

MedBrief facilitates the secure transfer and review of patient medical records, confidential documents and radiology. It is not an eDiscovery product but can provide significant value when deployed in conjunction with such products, particularly when used in the context of Expert or Counsel review.

Designed for use by both lawyers and medical experts the system can present indexed medical records, confidential documents and radiology all through a single webpage without the need to install any software. It is currently being used in over 8,000 clinical negligence and personal injury matters for firms across the UK together with a number of international mass tort and product recall cases for international clients.

MedBrief will solves many of the issues we all experience in respect of radiology distribution. We will no longer need to send you USBs, file-share links or downloads. Over 6,000 experts, lawyers and barristers are now using MedBrief to review medical imagery. Its latest version is a CE certified viewer accessible from any internet browser and works on PC's, Macs, android tablets and iPads.

MedBrief does not have any local server requirement and as such can be deployed and supported at short-notice into new jurisdictions, beyond a web-browser there is no client side installation.

Please get in contact with us and we'll explain more about what we do and how we might be able to assist you.

Owned/Supplied by :	MedBrief
Used by :	MedBrief

8.2.44 Millnet DocBuster

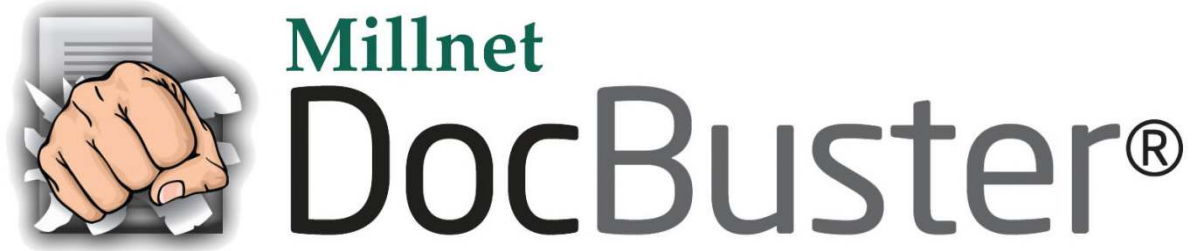

eDocBuster is developed by Millnet, the UK’s leading provider of legal document services to law firms.

DocBuster is an integral part of Millnet’s 24/7 document operation, and is used by businesses across the UK. DocBuster makes it easy for law firms to batch print documents such as emails and their attachments, and common file types including Word, Excel and PDF. DocBuster is tried and tested technology, used within leading UK law firms. Millnet has printed in excess of 100 million pages of emails, MS Office documents (Word, Excel, PowerPoint), PDFs and other file types with the program over the past 10 years. DocBuster is easy to install, requiring little or no IT involvement.

DocBuster is designed to be

- Easy to Use.
- Powerful.
- Cost Effective.

Main Features

- Page count reporting.
- Identifies password protected and corrupted files.
- Chronological ordering of emails.
- Formatting of Excel spread sheets.
- Page capping on large documents.
- Detailed slip sheets, making it easier to identify a documents origin.
- Plus many other features that will assist lawyers in their day-to-day work requirements.
- UK based support, DocBuster is backed up by the largest outsourced secure 24/7 legal document production facility in the UK.

Owned/Supplied by :	Consilio
Used by :	Millnet Document Services, Print rooms in various law firms.

8.2.45 Milyli Relativity product suite

BLACKOUT BY MILYLI



Blackout, a Milyli product, is the easiest, most comprehensive way to redact information in Relativity.

Blackout can automatically redact and mark up native Excel content and image files in Relativity. With Blackout, a review team can create rules and then apply them against a document set to redact documents at high-speed and high volume.

Benefits of Blackout:

- Cut time and costs out of reviews with automated redactions
- Create efficiencies that reduce human error by redacting words, phrases, and text patterns simultaneously
- Ensure privileged information is secure while retaining native documents

How Does Blackout Work?

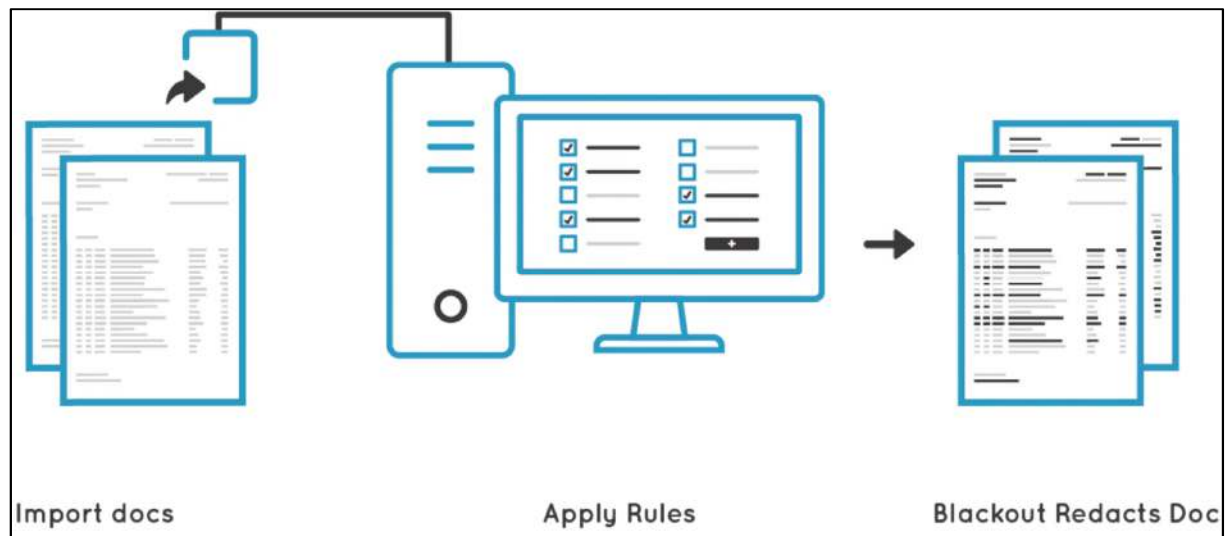

Features of Blackout:

- Auto-redact images and native Excel files
- Seamlessly integrated into the Relativity viewer
- Quality check with approval, reject, and override options
- Mass import/export functions via .CSV file

Learn and see more at: <https://www.milyli.com/blackout>

BROADCAST BY MILYLI



Broadcast, a Milyli product, allows Relativity users to report across workspaces and clients—without ever leaving the Relativity platform.

Users are able to choose from a range of charts and graphs to create detailed, attractive reports on all of your eDiscovery data, then share them easily with stakeholders, review teams, and clients to improve the quality of reviews.

Benefits of Broadcast:

- Save time with more efficient reporting than what's native to Relativity
- Create aesthetically pleasing, easy-to-understand reports for any stakeholder group
- Surface insights that can be used to improve workflows, individual reviewer performance, and more

How Does Broadcast Work?

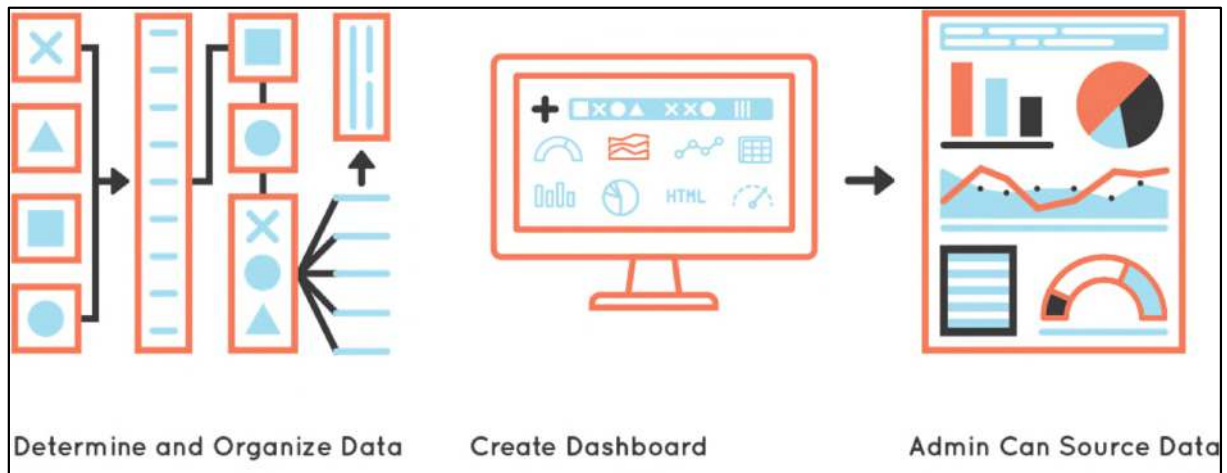

Features of Broadcast:

- Customize dashboards with drag-and-drop functionality for tables, bar charts, line graphs, pie charts, and more
- Create multiple dashboards with permissions based on user groups
- Build custom SQL reports or have Milyli's success team set up dashboards
- Add branding, links, or messages to reports via an HTML widget

Learn and see more at: <https://www.milyli.com/broadcast>

CHRONICLE BY MILYLI



Chronicle, a Milyli product, is the easiest way to build privilege logs in Relativity.

Chronicle starts constructing a privilege log as soon as the underlying documents enter review. Using templates that recognize both Relativity fields and dynamic custom fields, Chronicle is able to concatenate information and immediately reflect coding decisions and update as changes are made. This not only simplifies and streamlines the process of assembling a privilege log, but it also allows viewers to view and revise in real time.

Build a consistent, defensible narrative while reducing the expense and time it takes to construct a privilege log.

Benefits of Chronicle:

- Simplify the creation, review, and delivery of privilege logs in a way that also saves time and effort
- Create consistent, clear, and complex narratives
- Automatically include documents tagged as privileged in real time
- Make changes rapidly without impact on the final delivery timetable

How Does Chronicle Work?

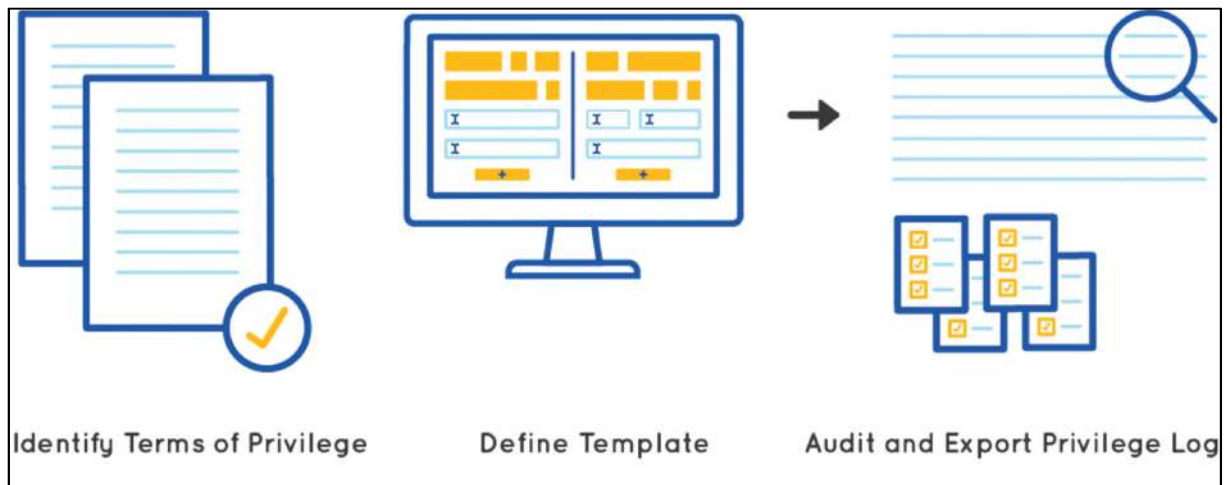

1. Start with an agreement to the terms of privilege.
2. Set up templates, which recognize both Relativity fields and dynamic custom fields.
3. Conduct review as information then populates on the Chronicle dashboard (exported as a .CSV).

Features of Chronicle:

- Template builder allows full control over the customization of the log
- Able to concatenate multiple document fields with plain text
- Uses Relativity saved searches to immediately recognize privileged documents
- Flags privileged docs not identified for the final Priv log output

- Easily exports privilege log .CSV file

Learn and see more at: <https://www.milyli.com/chronicle>

DELEGATE BY MILYLI



Delegate, a Milyli product, empowers legal professionals to get more from their Relativity investment while completely and safely preserving confidential information.

As a robust administration tool, Delegate allows Relativity hosts to create user and group level access settings for specific workspaces and matters—all within the same instance.

Benefits of Delegate:

- Equip end clients to better help themselves conduct reviews with more versatile permission settings
- Regain time spent managing and executing those requests and refocus on relationship-building customer service efforts
- Create users faster without compromising security in similar templates to those native to Relativity

How Does Delegate Work?

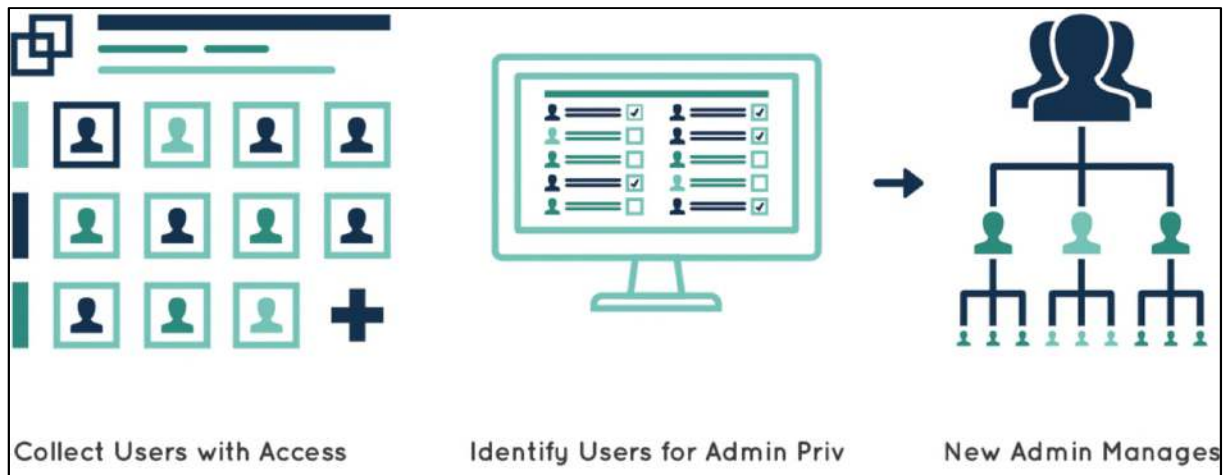

Features of Delegate:

- Seamlessly integrates with Relativity
- Offers templated user configurations and mass imports of users
- Accessible on mobile devices for on-the-go admin tasks
- Supports more thorough and granular auditing of reviews

Learn and see more at: <https://www.milyli.com/delegate>

TECHNOLOGIES INFORMATION

RELAY



Relay allows Relativity users to import documents and data directly from SQL-based systems into their instance without load files.

A Quick Look at Relay:

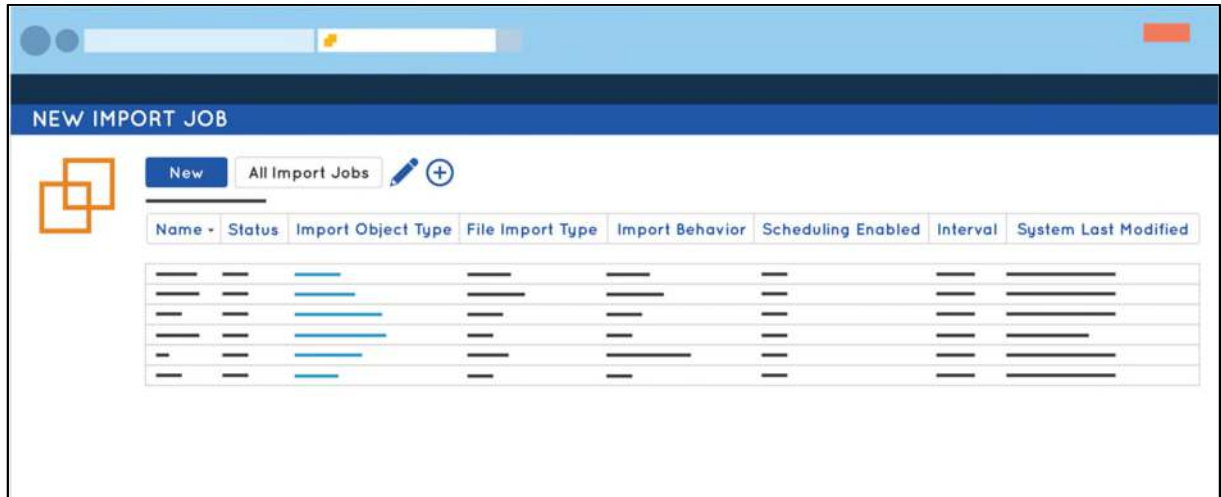

For benefits, features, and more visit: <https://www.milyli.com/relay>

BRIDGE



Bridge provides a framework to automate the movement of case data and work product from Concordance and Summation into Relativity — including data not typically supported by load files.

A Quick Look at Bridge:

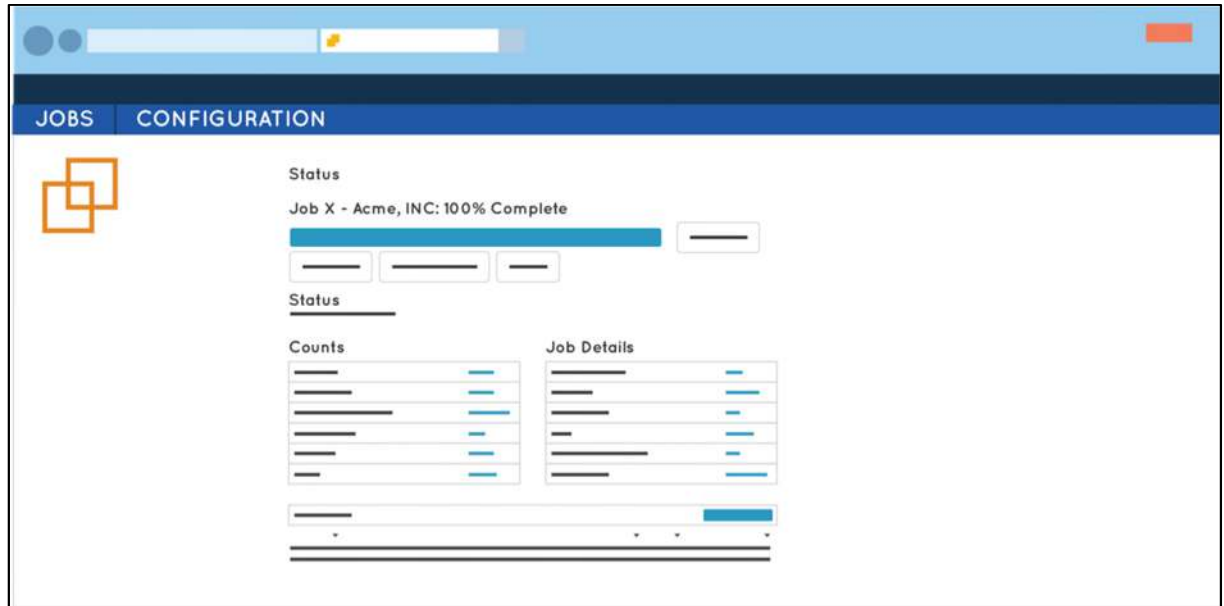

For benefits, features, and more visit: <https://www.milyli.com/bridge>

DITTO



Ditto saves Relativity users time and effort by replicating user permissions across workspaces or between groups in the same workspace.

A Quick Look at Ditto:

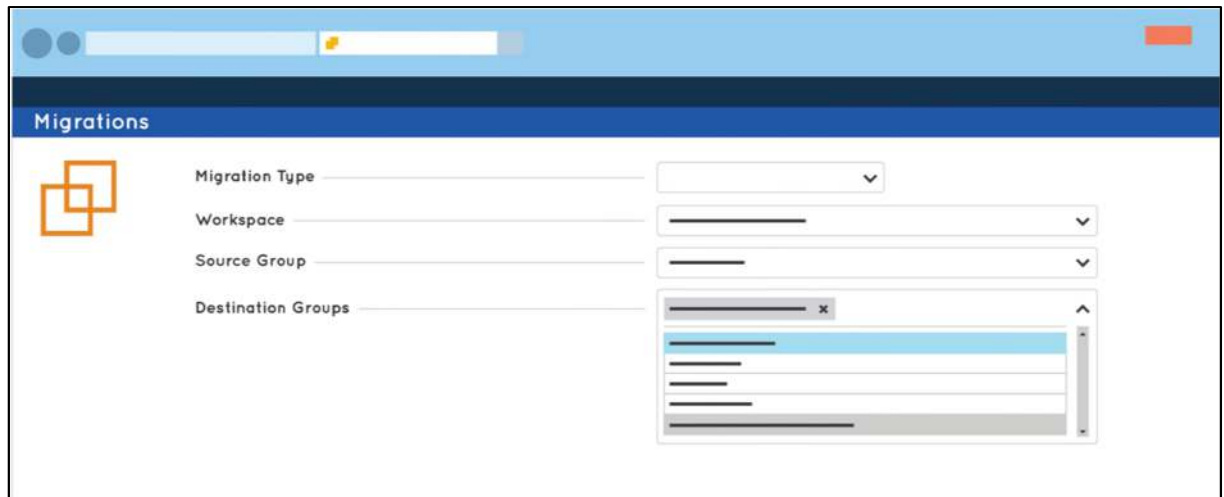

For benefits, features, and more visit: <https://www.milyli.com/ditto>

SCRIPT RUNNER



Script Runner allows Relativity users to automate the execution of Relativity Scripts found in the Relativity Script Library at the time(s) and frequency of their choosing.

A Quick Look at Script Runner:

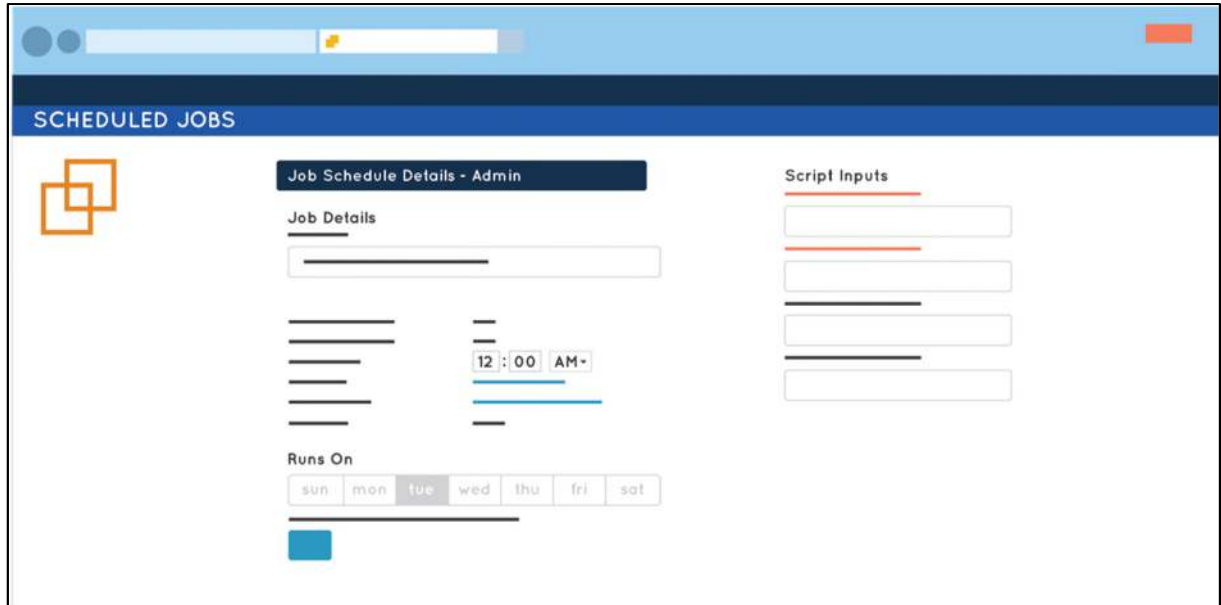

For benefits, features, and more visit: <https://www.milyli.com/script-runner>

TASK TRACKER



Task Tracker is a project management tool that allows users to manage day-to-day Relativity operations with ease, all without ever leaving Relativity.

A Quick Look at Task Tracker:

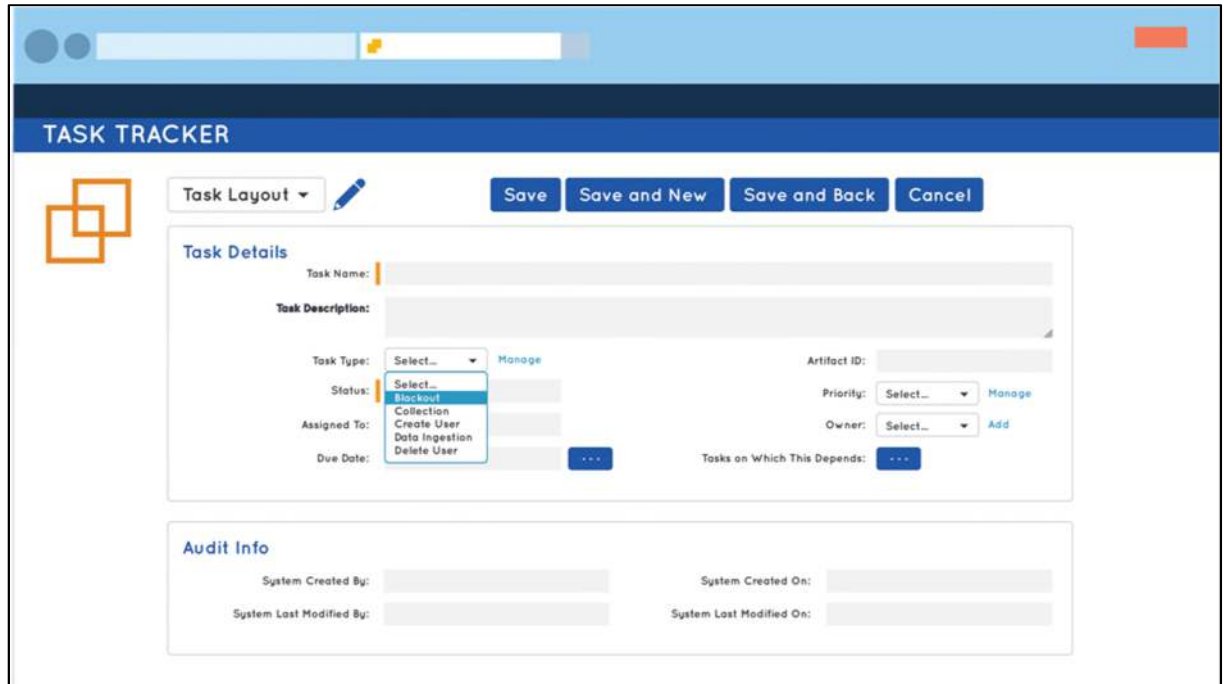

For benefits, features, and more visit: <https://www.milyli.com/task-tracker>

LICENSING MANAGER



Licensing Manager allows users to issue software licenses to customers without having to build the infrastructure necessary to maintain a licensing service.

A Quick Look at Licensing Manager:

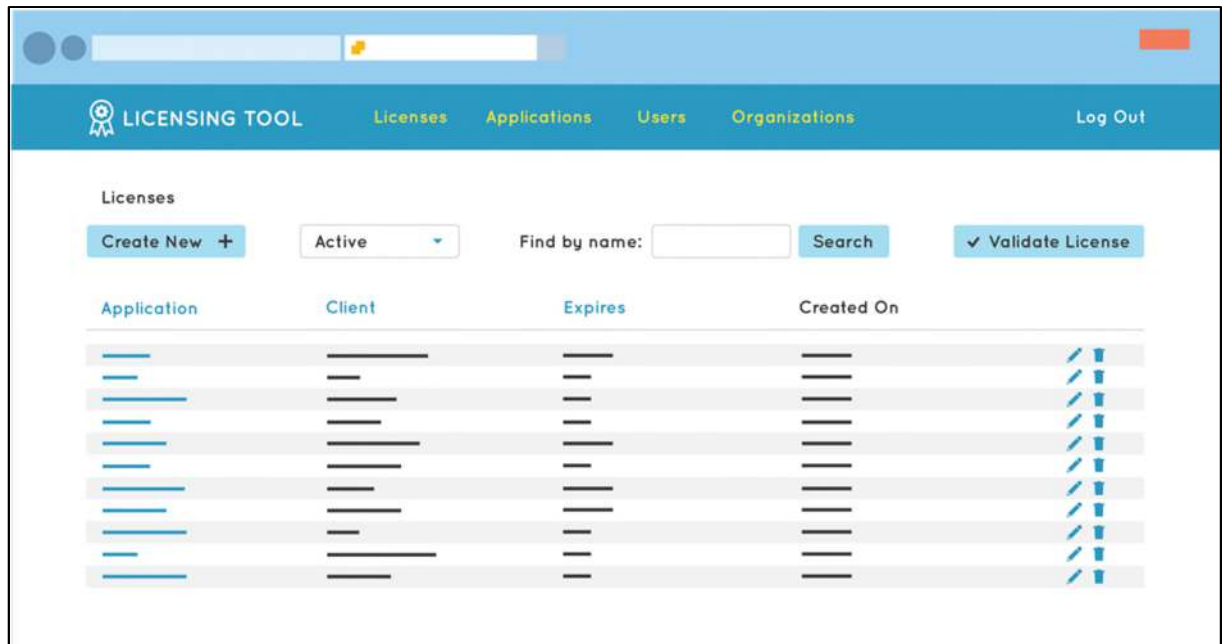

For benefits, features, and more visit: <https://www.milyli.com/licensing-manager>

ARM for Delegate



ARM for Delegate provides Delegate users access to ARM, Relativity’s official workspace migration tool. Use all of Delegate’s permission granting capabilities to allow clients to archive and restore workspaces.

A Quick Look at ARM for Delegate:

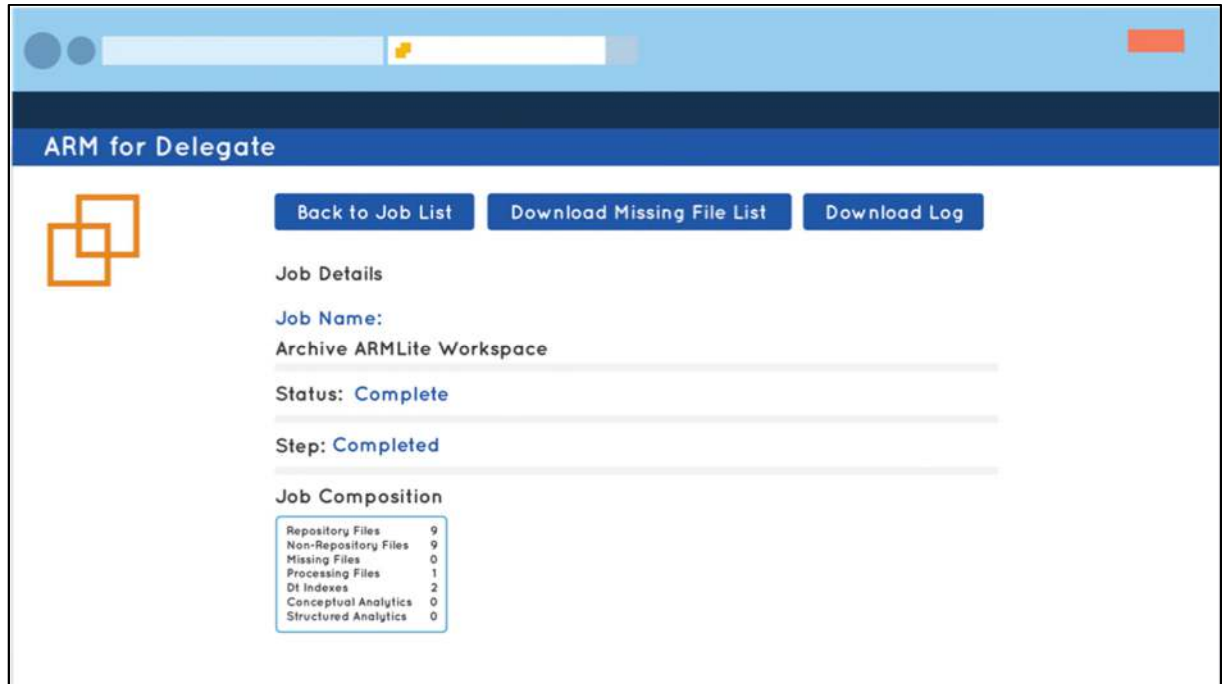

For benefits, features, and more visit: <https://www.milyli.com/arm-for-delegate>

CUSTOM DEVELOPMENT AND EDUCATION



Milyli offers custom development and developer education to help anyone “Make It Like You Like It.”

With thousands of development hours under their belt, the Milyli services team has an extensive history tackling challenges big and small for everyone from small law firms to eDiscovery leader, Relativity.

This includes assessing needs directly or assisting with resource management to cover migrations, integrations, technology transformation, team education (e.g., curriculum building), and more.

For more information visit: <https://www.milyli.com/services-overview>

Owned/Supplied by :	Milyli
Used by :	Akin Gump, Avalon, Commonwealth Legal, Complete Discovery Source, Compliance Discovery Solutions, D4, Deloitte MCS, Discovia, Driven, Epiq, FRA, Fronteo, Inventus, Kroll Ontrack, Law In Order, NightOwl Discovery, Oasis, ProSearch Strategies, Sky Discovery, Strategic Legal Solution, The Department of Justice, Xact Data Discovery

Broadcast

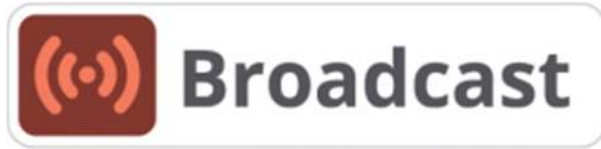

Wish you had an easy way to report on important eDiscovery data?

Broadcast is a Relativity reporting tool that allows you to report across workspaces and clients – without ever leaving Relativity. With Broadcast, you can choose from a wide range of charts and graphs to create detailed, attractive reports on all of your eDiscovery data and easily share those reports with stakeholders, review teams, and clients.



With Broadcast, you can:

- Report on case data by using SQL queries you write or add a [Reporting Pack](#) to generate common reports, like billing statistics or reviewer progress, without having to write your own SQL.
- View dashboards both within Relativity and via mobile devices.
- Create multiple dashboards per workspace or from the Relativity Admin area and set different permissions based on user groups.
- Choose from eight different kinds of charts for displaying case data – tables, two types of bar charts, line graphs, pie charts, area graphs, gauges, and speedometers.

The screenshot shows the Milyli dashboard interface. A 'Create New Widget' dialog box is open, allowing users to configure a new widget. The dialog includes the following fields and options:

- Title:** Enter Chart Title
- Link Type:** Open new tab
- Link URL:** ?dashboardid=10002
- Type:** A selection of chart types including HTML, Area, Bar, Pie, and others.
- Colors:** A grid of 12 color swatches for selection.
- Area Chart SQL Query:**

```

1 SELECT
2 CONVERT(varchar(5), [Date], 101)
3 ,[Collected]
4 ,[Processed]
5 ,[Reviewed]
6 ,[Produced]
7 FROM
8 [EDDSDB0].[CaseOverviewRollup]

```

The background dashboard features several widgets:

- Case Overview:** Displays 'Estimated Review Complete: Apr. 30, 2015', 'Active Reviewers: 23', and 'Total Document Count: 74,081'.
- Pages Imaged By Month:** A horizontal bar chart showing data for months 02/15, 01/15, 12/14, and 11/14.
- This Week:** A table listing dates from 03/14 to 03/20.
- Collect:** A bar chart showing 'Collected', 'Processed', 'Culled', and 'Promoted for Review' metrics.
- Daily Throughput - Previous 7 Days:** A bar chart showing 'Collected', 'Processed', 'Reviewed', and 'Produced' metrics.

- Add branding, links, or messages to users to your dashboards with an HTML widget, which can be built out by hand or generated dynamically using a SQL script.
- Customize dashboards by dragging, dropping, and resizing charts, and set custom color palettes at the dashboard and chart level.
- Let users drill into data and provide more context by linking Broadcast charts to items within Relativity, like saved searches or other Broadcast dashboards, as well as external sites and systems.

Chapter 8 – Supplier & Software Details

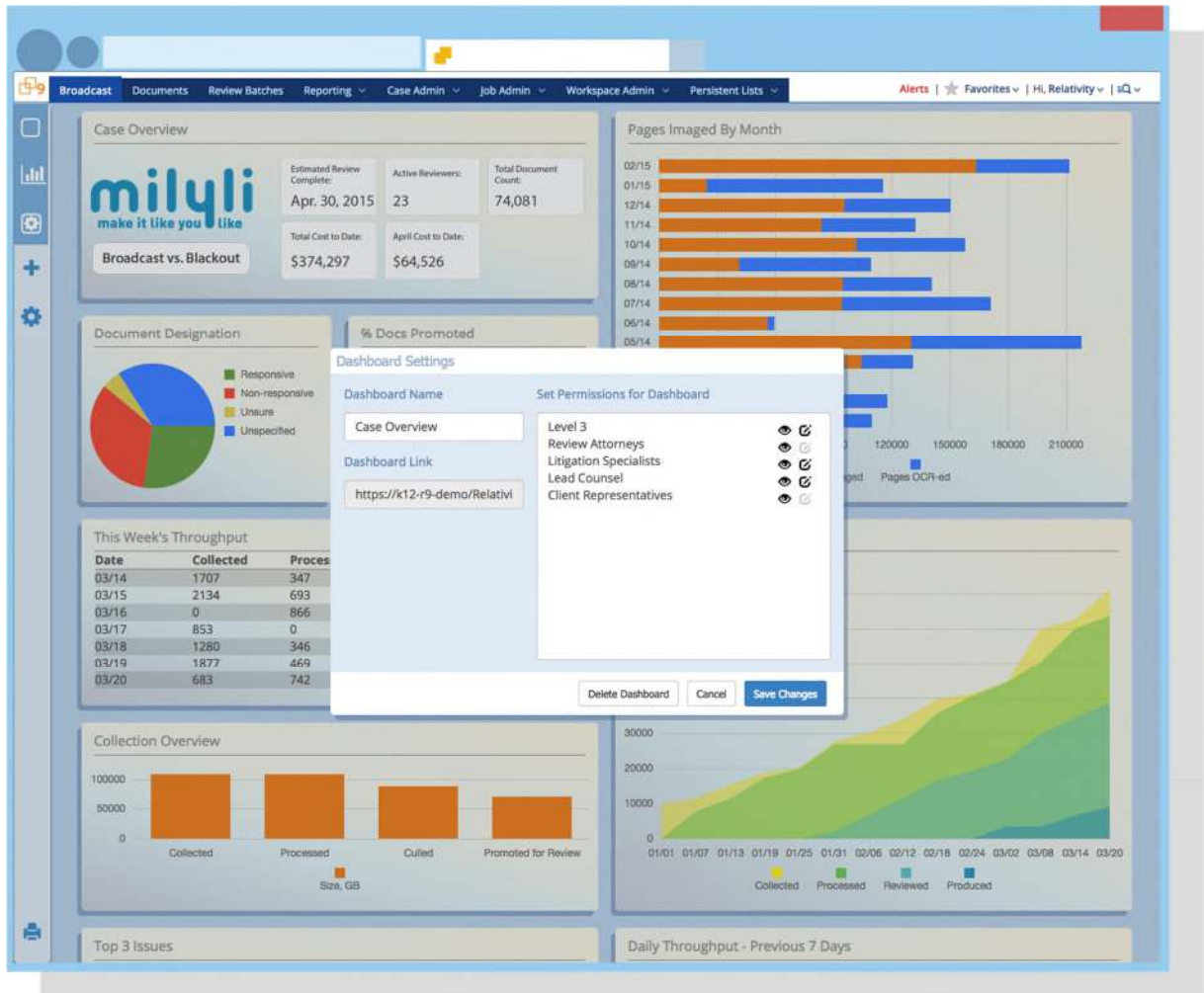

Owned/Supplied by :	Milyli
Used by :	Akin Gump Strauss Hauer & Field, Altep, Avalon Document Services, Ballard Spahr, Compliance Discovery Solutions, D4, DiscoverReady, DTI, eQ, Faegre Baker Daniels, Inventus, Kroll, Littler Mendelson, Modus, NightOwl Discovery, Paul, Weiss, Rifkind, Wharton, & Garrison, ProSearch, PWC

Delegate



Why spend time managing simple requests when you can empower clients instead?

Delegate is a Relativity self-administration tool that allows your clients to manage their own users, groups, matters, and workspaces with minimal training. Delegate’s intuitive interface and easy mobile access enable clients to serve themselves when and where they need to.

The benefits of Delegate include:

- Mobile-friendly access allowing Client Admins to work on-the-go
- Integrates directly with Relativity for a seamless user experience
- Supports Relativity versions 9.3 and higher, including Relativity 9.4’s authentication changes

System Administrators:

- Designate a specific group within a client as the Client Admin Group, and grant them permissions to Delegate so that clients can manage themselves
- Choose which workspace templates and resource pools Client Admins can use
- Access comprehensive, Delegate-specific audit logs across all clients
- Streamlined process making it faster and easier to manage cases in Relativity – for both service providers and clients

Client Administrators:

- Create, edit, and manage users, groups, workspaces, and matters for cases within a new Delegate Client Administration tab
- Access Delegate audit logs for users specific to client

Owned/Supplied by :	Milyli
Used by :	Altep, Complete Discovery Source, Compliance Discovery Solutions, D4, Discovia, DTI, Evolver, Fronteo, Oasis Discovery Partners, PWC, Sky Discovery,

Relay



Tired of having to go through a middleman to import documents into Relativity?

Relay is a data transfer tool that makes the process of importing into and exporting from Relativity more efficient. Whether you want to import from external databases or move data from workspace to workspace, Relay eliminates the need to use the Relativity Desktop Client and lets you import and export directly from Relativity.

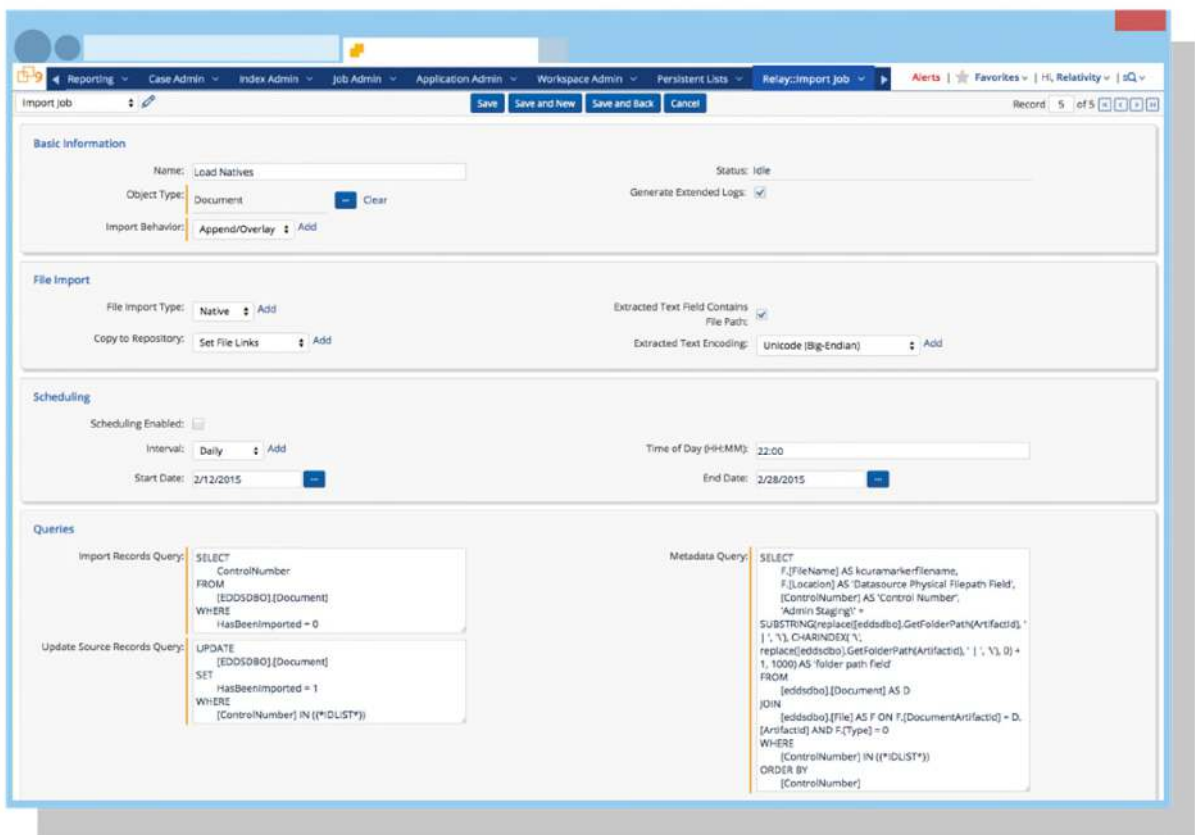

With Relay, you can:

- Import data from any system that uses Microsoft SQL Server – including processing engines, in-house tools, and Relativity itself
- Load natives, images, extracted text, and document metadata
- Load data into custom objects in your workspace
- Schedule Relativity data transfers to run at a future date or on a recurring basis – daily, weekly, or monthly

Chapter 8 – Supplier & Software Details

- Customize and secure the UI to only the groups you want and audit all import activity
- Quickly set up and deploy the application as part of a case template

Streamline the Relativity data transfer process, saving you time and money



The process of bringing data into Relativity can be tedious and time-consuming, but Relay offers a simple, efficient shortcut.

Owned/Supplied by :	Milyli
Used by :	Milyli and various law firms.

8.2.46 Mindseye TunnelVision

Mindseye TunnelVision is a leading third party platform for the processing of electronic data during legal proceedings. TunnelVision provides powerful data assessment, interactive filtering and native processing.

Simple, Workflow-based Navigation

TunnelVision was designed with a clean, straightforward, easy-to-use interface. And because TunnelVision is organized based on workflow, how you use it maps to steps in the process – it has built-in stop-points around key quality control or decision points.

Comprehensive – and Easy – Reporting that Tells a Story

Reporting is a critical function, but one that often falls short of real-world needs. TunnelVision excels at delivering the data you need, when you need it, because it was built with reporting as part of the initial design, not added as an afterthought. And while some systems provide dashboards that focus on the processing project, or even custodians of the data set, TunnelVision delivers detailed reports around the lifecycle of each file and processing step to help you build and share the story of your data. You can create reports based on actions you’ve performed in the application – giving you the ability to view the story from multiple perspectives, as broad or granular as you wish. And you can generate and export reports right through the TunnelVision interface – no back-end, manual database queries required.

Clear Exception Reporting and Handling

When it comes to eDiscovery, unknowns represent big risks. And if you can’t account for everything in your data set, your unknowns – and your risks – increase. TunnelVision tracks every file you enter into the system and documents whether it’s filtered, is an exception, or has been exported. Not only does TunnelVision report on exceptions, it also lets you know when there is a processing issue and gives you additional details to support defensibility.

TunnelVision provides:

- Simple and intuitive web-based design created to support any level of user with minimal training, anywhere.
- Rapid native processing quickly makes data discoverable.
- Powerful and transparent search features enable drill down results to see all variations, sampling to validate precision, and flexibility to refine as necessary.
- Extensive metadata filtering and analysis features assist in prioritizing what to look at and when.
- Flexible investigative and analysis tools enable better insight into any data identified.
- 30+ report formats enable users to save all work product and details to several formats including PDF, Excel, Word, and many more.
- Fast export of targeted data and work product to downstream review.

Owned/Supplied by :	Mindseye
Used by :	Ankura, Integreon.

8.2.47 MM/PC

MM/PC, written and wholly owned by eMag Solutions, is used around the world by corporations, Law Firms, Service Providers, eDiscovery Vendors, Law Enforcement bodies and Government Agencies to provide tape services.

MM/PC restores data from tapes of any type, created using any backup software. eMag also utilises original (native) systems such as Netbackup, Arcserve, Tivoli etc. and other specialist tape utilities to supplement services.

A wide range of voice recording systems is also fully supported by MM/PC, quickly and cost effectively providing an index to calls stored on tape and providing the ability to select and review those calls.

Owned/Supplied by :	eMag Solutions
Used by :	eMag Solutions

8.2.48 Morae Software Suite

Audio.IQ

Audio.IQ is Morae Global's audio eDiscovery, monitoring, and compliance tool. <https://www.moraeglobal.com/audioiq/>. Audio.IQ is our proprietary audio platform developed in partnership with CallMiner, the industry leader in speech analytics.

During audio processing, the platform decompresses and enriches the data, capturing a wealth of data for each file including searchable text transcripts and metadata. Speech analytics goes beyond speech recognition, converting speech into structured text and meaningful units of data. The platform allows our audio experts to group calls by data characteristics and qualities.

In the context of eDiscovery, the audio solution is a fully managed service and, unlike other product offerings, Clutch provides a dedicated team of industry professionals to manage workflows, review teams, and progress, to report findings, and to conduct audio productions on time and to specification.

The two additional use cases for Audio.IQ are proactive monitoring or business function analytics and sales compliance. Call scoring, using data characteristics to rate calls based on criteria provided by the business, allow for prioritization or immediate escalation of calls for compliance assessment.

Capture.IQ

Capture.IQ, a revolutionary contract analytics platform designed to help our clients dig deeper into their contract data. <https://www.moraeglobal.com/captureiq/> A fully-managed service, Capture.IQ extracts and codifies key reference data within all forms of legal and financial agreements allowing firms to easily access and make sense of their internal data.

Capture.IQ manages the entire financial and legal agreement life cycle by automating the capture and reconciliation of key reference data. The data extracted is subsequently reviewed and validated by our team of contract analytics experts. This process enables us to efficiently reconcile inaccurate, inconsistent or flawed reference data and to return accurate and fully validated data.

Additional use cases for Capture.IQ include the control of and regular surveillance over ISDA agreements, financial derivative term sheets, issuance documents and trade data; and the implementation and continuous monitoring of GDPR change management programmes and their ongoing GDPR compliance. The user-friendly platform offers easy and repeatable ways to identify and protect Personally Identifiable Information (PII) for GDPR purposes and it can be customised to reflect your GDPR implementation workflow.

ClutchCumulus

In our digital age, the cloud has changed everything. By 2020, 92 percent of all data centre traffic will be in the cloud and that's not by accident. Cloud-based platforms deliver superior scalability, improved data security and unmatched power

<https://www.moraeglobal.com/ecumulus/>

Cloud-based eDiscovery on the RelativityOne platform with secure processing, review, hosting and production by CLUTCH.

Deploying in the cloud allows us to deliver our state-of-the-art eDiscovery and global document review solutions – previously only available to the world's largest and most sophisticated financial institutions – on any and all eDiscovery projects, no matter the size or complexity.

Simple, fast, predictable eDiscovery at an unbeatable price – we call it ClutchCumulus.

ClutchCumulus transforms the way eDiscovery is delivered. No other eDiscovery

Chapter 8 – Supplier & Software Details

service offers so much.

Owned/Supplied by :	Morae
Used by :	Morae

8.2.49 Nexidia

The growth of electronic communications including voicemail, call-centre recordings, regulatory compliance, and digital conferences, has resulted in increased volumes of discoverable audio content. Searching these recorded audio and video files presents significant issues for legal professionals, corporate compliance managers, and government regulators. Nexidia has focused on audio and video content for over a decade and brings unparalleled experience and technology to your team.

Nexidia's Audio Discovery technology uncovers relevant information and solves the considerable challenges of audio search and review by:

- Quickly locating relevant content - helping legal professionals understand the nature of the evidence.
- Significantly reducing the cost of audio review by allowing reviewers to quickly pin-point searches and deliver relevant data.
- Complementing and incorporating traditional electronic document discovery.

Nexidia enables law firms, corporate legal departments, and regulators to locate critical evidence in the shortest time, with the highest accuracy, and at the most affordable price. Nexidia's patented audio search technology increases the speed and accuracy of searches against large collections of audio content by eliminating the need to convert speech to text. Organizations can now review and search large amounts of unstructured content in a matter of days, rather than months, significantly reducing total project costs and making short deadlines achievable.

Audio Discovery

Nexidia is the fastest and only scalable audio discovery solution that combines technology, audio expertise, and the highest levels of project management. Traditionally, law firms and electronic discovery companies have relied on manual transcription or human listening to review and investigate audio files. However, transcription is slow and costly, and human listening is an ineffective process for locating relevant content. Neither transcription nor human listening is scalable or capable of economically handling the large amounts of audio data being demanded and produced today.

Automating the review process eliminates the errors caused by fatigue, boredom and other distractions that typically result from human listening. Nexidia's technology returns highly accurate results regardless of audio quality, speaker accents, dialects, slang, and non-standard grammatical patterns.

Nexidia's audio discovery consultants work every day with highly sensitive content. They know that processing audio discovery is different from other forms of electronic information and work closely with reviewers to maximize productivity, workflow, and achieve the best possible result.

Compliance and Corporate Governance

Whether required by a regulatory agency or internal policy, corporations are creating and storing significant volumes of audio and video files. Nexidia allows counsel and corporate officers to proactively monitor and quickly identify audio content for discovery, internal, or regulatory investigations. This flexible platform significantly speeds the legal review process by allowing counsel to organize and effectively search all recorded content and pertinent data, including metadata.

Nexidia Forensic Search

Whether your challenge is legal discovery, corporate compliance, or governance, Nexidia Forensic Search offers tremendous flexibility and speed, indexing recorded audio up to 20,000 hours per day. This makes large volumes of audio available in just

Chapter 8 – Supplier & Software Details

a matter of days for search, automated analysis, in-depth review, and targeted listening.

As a result of its patented phonetic technology and approach, Nexidia:

- Provides better ROI by creating a more thorough approach, at a fraction of the costs of traditional methods of transcription or human listening.
- Quickly and accurately allows legal professionals to identify, prioritize, and review relevant data and respond to short deadlines.
- Enables compliance and corporate officers to identify subject matter, conduct preliminary searches, and prioritize the most relevant records for listening
- Provides a disciplined framework to review audio files for privilege, responsiveness, and other issues.
- Reduces judgment errors caused by fatigue, and provides an accurate assessment of critical content.
- Gives users an easy-to-use interface enabling quick, efficient ad-hoc searches and drill-down into specific content - even proper names, jargon, and specialized industry terms.
- Allows users to continue using their preferred platform for non-audio/video processing and review.



Owned/Supplied by :	Nexidia
Used by :	7Safe, Anexsys, CYFOR, Consilio, Deloitte, KPMG.

8.2.50 NightOwl Discovery Software Suite

For data collection, NightOwl uses the latest technology including but not limited to EnCase[®], AccessData[®], Exterro[®] and Cellebrite[®]

NightOwl offers Relativity[®] ECA, Nuix[®] ECA, LAW[®] EDA, Veritas[®] and Brainspace[®] for ECA. These systems provide what NightOwl refers to as our Data Intelligence module. These tools can be combined in unique and interesting workflows to offer a flexible high-speed search and facet navigation, advanced textual analytics, and intuitive data visualizations all within a single login that is directly connected to the review workspace.

NightOwl processes data using Nuix. Our processing environment at peak performance can process 4.5 TB of data per 24 hours. Average processing rates in a typical real-world application are 125 GB per hour.

NightOwl has been a Relativity Premium Hosting Partner for eight years and has been a “Best in Service” partner for the past eight years. We operate a robust and secure Relativity environment in the US, comprised of both a primary site in Minneapolis and a complete warm backup environment in Chicago. We also operate NightOwl data centers internationally with separate Relativity instances in the US and EU (Dublin, Ireland and Dusseldorf, Germany). Relativity forms the foundation for nearly all of NightOwl’s discovery management engagements. All NightOwl staff hold various Relativity certifications including Relativity Infrastructure Specialist.

To optimize process in Relativity, NightOwl develops automated workflows that force additional or automated actions when coding documents. NightOwl has dedicated staff working with our client teams in developing a wide variety of coding decision “event handlers”. These event handlers generally fall into one of the following four categories: Validation or auto-population of fields based on coding decisions, forcing fields or decisions into a required state when specific criteria is met, sending emails to specified email addresses when specific fields or coding decisions are made, or querying and updating fields and decisions on an automated recurring schedule.

NightOwl has developed proprietary Relativity applications including MissionControl[®], which provides clients and internal operations teams with a dedicated administrative and production control module within NightOwl’s instances of Relativity. MissionControl was created to track all attributes and data points associated with each client request. MissionControl enables our dedicated group of quality control analysts follow a standard automated process to ensure that each of those 860 data points have passed corresponding quality controls to exceed our high standards for work product.

NightOwl has also developed another proprietary Relativity application that provides our clients the opportunity to reuse work product of individual documents across multiple matters in their portfolio. DecisionCenter[®] tracks all attorney decisions on documents, finds hash duplicates in other matters within the client’s portfolio and provides automated suggestions as to how those documents may be now classified based off of prior decisions. DecisionCenter is regularly used to kick start ECA processes, prioritize document review and provides an additional layer in quality controls on document reviews.

NightOwl’s proprietary dashboard application, nSight[®], allows users to access reports and review real-time information through secure, online, web-based client dashboard interfaces. nSight[®] provides clients with graphical visibility into total Relativity hosting storage, total processed data, total users, data breakdown by case, users by case, custodians by case, media by case and task list by case. These data points are arranged in a simple, easy to navigate interface that allows the client to drill down from general information into increasingly more detailed information for each case, media delivery or custodian.

Chapter 8 – Supplier & Software Details

Additionally, NightOwl supports various third-party Relativity add-ons, which provide search and redaction functionality, including regular expressions to locate PII and HIPAA protected PHI, audio/video transcription, native file redaction, and advanced textual analytics.

NightOwl uses Relativity Analytics for analytics and Relativity Assisted Review for TAR.



The screenshot displays the 'Reviews' section of the nSight interface. At the top, the NightOwlDiscovery logo is on the left and the nSight logo with 'Welcome MediLabs' and a 'Log Out' link is on the right. A vertical sidebar on the left contains several icons. The main content area is titled 'Reviews' and features two review cards. The first card, 'China Review', shows a '97% Review Progress' in a blue box and '1,789,336 Documents' in a grey box. The second card, 'EU Review', shows a '67% Review Progress' in a blue box and '2,592,104 Documents' in a grey box.

The screenshot displays the 'Custodians' section of the nSight interface. At the top, the NightOwlDiscovery logo is on the left and the nSight logo with 'Welcome MediLabs' and a 'Log Out' link is on the right. A vertical sidebar on the left contains several icons. The main content area is titled 'Custodians' and includes a search bar. Below the search bar is a table with two columns: 'Name' and 'Cases'. The table contains two entries: 'Clinton, Brian' with 'EU Review' and 'Hawke, Vincent' with 'China Review' and 'EU Review'. At the bottom of the table, it says 'Showing 1 to 2 of 2 entries'.

Name	Cases
Clinton, Brian	EU Review
Hawke, Vincent	China Review EU Review

Chapter 8 – Supplier & Software Details



Owned/Supplied by :	NightOwl
Used by :	NightOwl

8.2.51 Nuix (Including Nuix Ringtail)

END-TO-END DISCOVERY

Processing, Review & Production

- Nuix eDiscovery combines the power of Nuix and Ringtail to offer an integrated solution for your entire discovery workflow, from the endpoint to the courtroom.
- *Flexible Deployment.* Nuix Ringtail can run where you need it— behind your firewall, in the cloud, or through one of our hosting partners.
- *Massive Scale.* Nuix Ringtail has proven scalability—from a single PST to a 100-million-document global class action and everything in between.
- *One Platform for Many Needs.* Nuix Ringtail can handle your discovery, investigation, information governance, and data privacy needs—as well as freedom-of-information requirements for government customers.
- *Reduced Risk.* The integration between Ringtail and Nuix saves time and reduces the risk of human errors by making the multi-step process of data processing a point-and-click exercise.
- *Amazingly Fast Linear Review.* Ringtail's intuitive user interface and intelligent automation capabilities allow reviewers to complete each task with fewer clicks. Multiply that by a team of reviewers and millions of items and watch your savings add up.

NUIX WORKSTATION PROCESSING/ECA

Nuix Workstation is the world’s leading technology for extracting intelligence from high-volume unstructured, semi-structured, and structured data. It provides unmatched speed, scale, and accuracy to processing, searching, indexing, and analysing the information you need.

- *One window into all the evidence.* Collect all available data into a single location, use advanced investigative techniques to understand the content and context, and then act on the intelligence you’ve extracted.

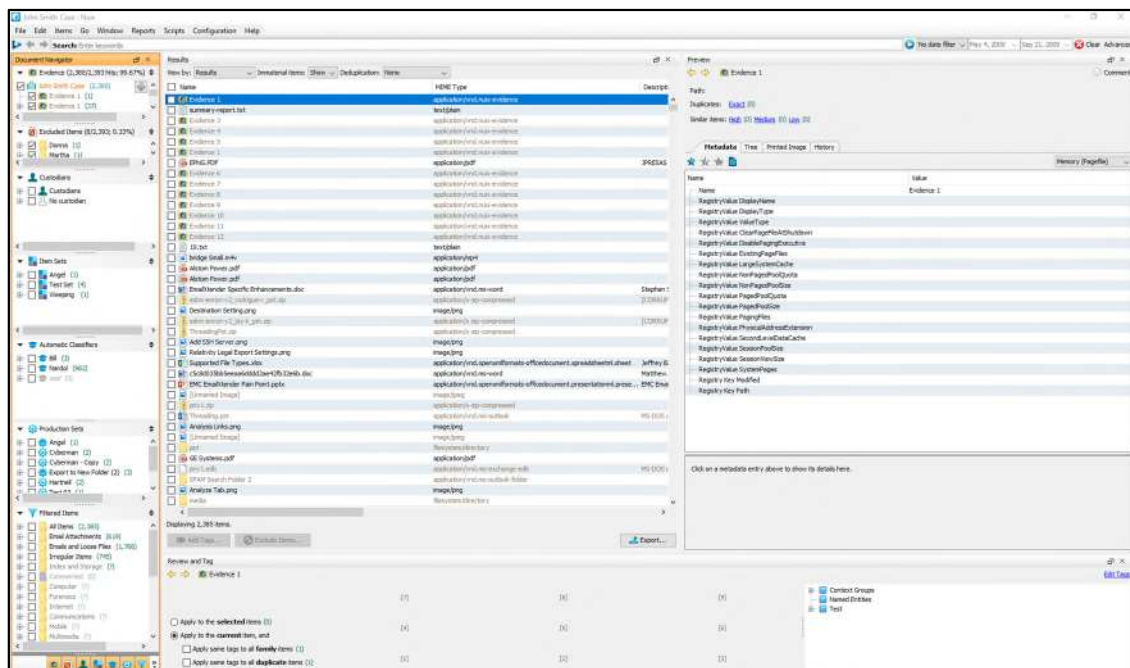

- *Scalability up to the largest data volumes.* No matter how little or how much data you have, Nux lets you start searching and managing it before other tools even finish processing.
- *Automated connections.* Nux Workstation automatically identifies and correlates key intelligence items such as company names, sums of money, email addresses, IP addresses, and national identity, phone, and credit card numbers. The Data Finder extension gives you more than 180 additional identifiers and the ability to create your own.



- *Flexible workflows.* The software is as flexible as you need it, with deployment options, customization scripts, and specialized workflows that maximize productivity and save time.
- *Include all Possible Information.* Nux Workstation processes 10 dimensions of data, including human-generated, multimedia, log files, user data, network, cloud, structured, real-time, communication patterns, and mobile.

Ringtail Document Review

Ringtail is a premier document review platform that delivers a unique visual approach to the many phases of e-discovery - from early case assessments and investigations to document review and trial preparation - that enable law firms, corporations and government agencies to master the details of any legal matter. Ringtail can be implemented as either an on-premise installation or via a partner or Nux hosted cloud. Whether on premise or hosted, Ringtail scales to support simultaneous, concurrent process, load, analysis, review and production operations.

Ringtail's core functionality includes:

- **Fast, predictable data processing** – Ringtail's integrated Nux processing delivers world-class speed and performance at the start of every matter.
- **Integrated analytics** – The fastest way to find key facts, visualize trends, identify important documents and eliminate irrelevant documents before review. Ringtail's advanced analytics accelerate the development of case strategy.
- **Visual document review** – Ringtail combines powerful keyword search, concept clustering and e-discovery's best, and only, visual review tool, Document Mapper™.

Chapter 8 – Supplier & Software Details

- **Visual Predictive Coding** – From rapid training to flexible coding Ringtail's predictive coding is intuitive, easy-to-use and applicable to a wide variety of review projects.
- **Flexible, secure production** - Ringtail's redaction and production tools provide not only the dexterity to handle simple projects, but also the ability to tackle your most complex, difficult production requests in a defensible, repeatable manner.
- **Massive scalability** – Industry-leading scalability and security provides unparalleled flexibility for handling both single and multi-matter project demands.
- **Simplified case administration** – Effortlessly manage cases, groups, security, workflows and reporting from one central administration page.
- **Award-Winning Usability** – Designed to empower rapid decision making and improve productivity for the entire legal team, Ringtail's clear, colorful and concise user interface is easy to learn and use.

In addition to the many features in the platform, Ringtail offers an extensive eLearning Library inclusive of interactive training videos. From basic overviews to “how-to” videos, visit Ringtail University on the Ringtail website, www.ringtail.com, to watch more than thirty interactive Ringtail training videos. Ringtail University also includes Ringtail certification programs for end users and administrators. Ringtail certification is offered for a small per-person and per-course fee.

Feature Highlight: Customizable Workspaces

Ringtail features a highly customizable layout which enables legal teams to optimize the user interface for the specific task at hand. From early case assessments to investigations to review projects multiple panes can be toggled on and off and windows arranged to suit the user's needs.

The screenshot displays the Ringtail software interface. The central pane shows an Excel Online spreadsheet titled "Flash to Actual P&L Allocation" with a table of financial data. The table includes columns for "Flash", "Flash to Actual P&L Allocation", and "Actual", with sub-columns for "MTM value", "Site Profile", "LCOG/ DSM", "Retail Trading", "Wholesale trading", and "RTO". The data shows values for various categories, with a total of \$1,800 for Flash and \$1,000 for Actual.

Flash	Flash to Actual P&L Allocation					Actual
MTM value	Site Profile	LCOG/ DSM	Retail Trading	Wholesale trading	RTO	
95	95	0	95	95	100	
0	5	0	0	0	0	
\$0	\$10	\$0	\$10	\$0	\$0	
\$0	\$50	\$0	\$0	\$0	\$0	
95	95	0	95	95	100	
\$20	\$0	\$0	\$20	\$0	\$0	
0	0	0	10	0	10	
\$0	\$0	\$0	(\$950)	\$0	\$0	
\$1,800	\$50	\$0	(\$950)	\$0	\$1,000	

The right-hand side of the interface features a "Review" panel with a document list, a "Threading" section, and a "Similar" section. The document list includes entries like "WHS/Retail Systems In...", "whs_retail_analysis...", "[Unnamed Sprea...", and "Visio format - Retail...". The "Review" panel includes sections for "Relevance" (Not Coded, Relevant, Not Relevant, Privilege Relevant, Privilege Not Relevant), "Relevance Details" (Corruption, Deconsolidation, Fraud, Potential Liability, Watchdogs), "Privilege Asserted" (Attorney Client, Work Product), and "Comments".

Feature Highlight: Document Mapper

Ringtail's innovative Document Mapper clusters documents based on conceptual similarity. Fully searchable and interactive, these Maps allow reviewers to shape, shift, filter and sift documents to reveal key facts and key fact patterns. A Ringtail exclusive, Document Mapper is the original e-discovery concept clustering visualization.

Chapter 8 – Supplier & Software Details

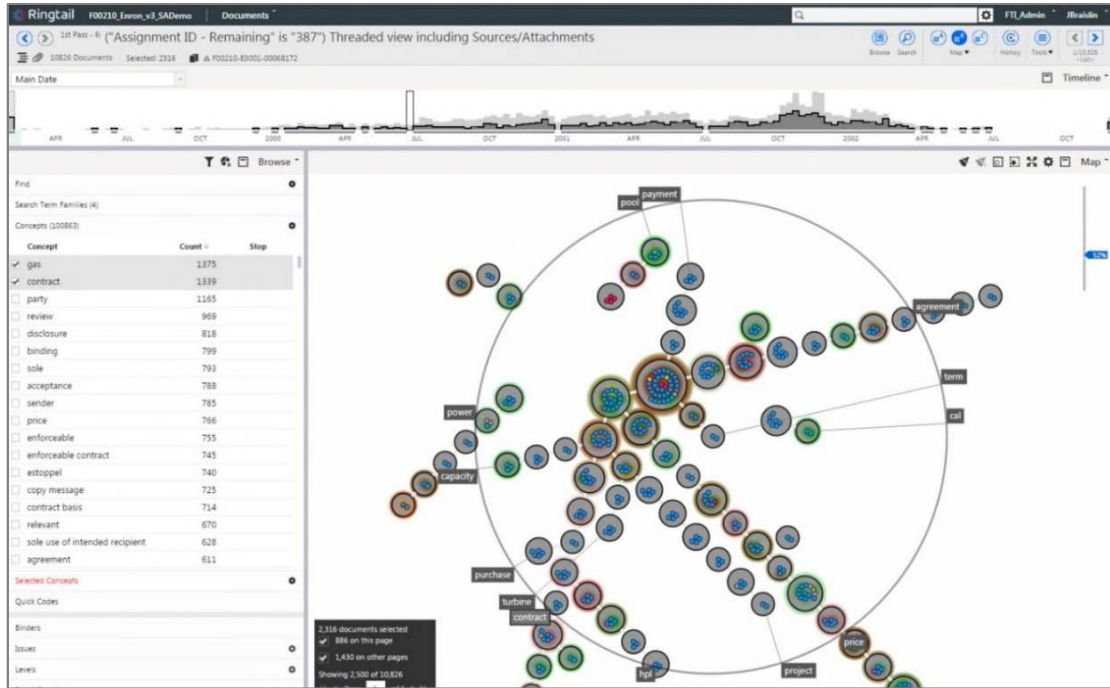

Feature Highlights: Search Term Families

Efficiently create, run and automatically updated search terms with Ringtail's Search Term refinements. Add multiple search terms as at once or bulk upload with spreadsheets to more effectively create Ringtail searches.

Search term family		Document set				Coding field					
Keyword Testing		All documents in the case				Core - Relev					
Term label	Counts				Coding						
	Document	Family	Unique document	Unique family	Recall	Precision	Positive with term	Negative with term	Not coded with term	Positive without term	Negative without term
Total	3,371	5,892			17.3...	29.62%	173	411	2,787	825	7,615
california	1,861	2,992	301	509	7.01...	36.27%	70	123	1,668	928	7,903
california and price	768	1,613	0	0	5.51...	45.08%	55	67	646	943	7,959
Churn	30	67	22	22	0.10...	33.33%	1	2	27	997	8,024
Exports	170	565	72	156	0.80...	44.44%	8	10	152	990	8,016
Williams	1,741	2,464	587	757	7.72...	27.70%	77	201	1,463	921	7,825
Sp-15	71	299	21	63	0.80...	72.73%	8	3	60	990	8,023
SoCalGas	16	46	7	7	0.00...	0.00%	0	8	8	998	8,018
raptor	90	175	43	72	0.80...	33.33%	8	16	66	990	8,010
Price caps	204	631	19	25	1.30...	59.09%	13	9	182	985	8,017
LIM	139	463	104	240	1.00...	22.73%	10	34	95	988	7,992
Hedge	818	2,319	517	1,160	6.31...	39.62%	63	96	659	935	7,990

Feature Highlight: Social Network Analytics

Ringtail's Social Network Analytics gives users the ability to view organizational connections and communication flow and refine data sets based on time, date, custodian, concepts, and keywords. All in an easy to implement preconfigured investigation workspace. With Ringtail Social Network Analytics you can:

- View and refine communication flow between organizations via URL or organization name, including email and phone calls.
- Select individuals of interest to view email and phone communication flow within and between key organizations and parties.

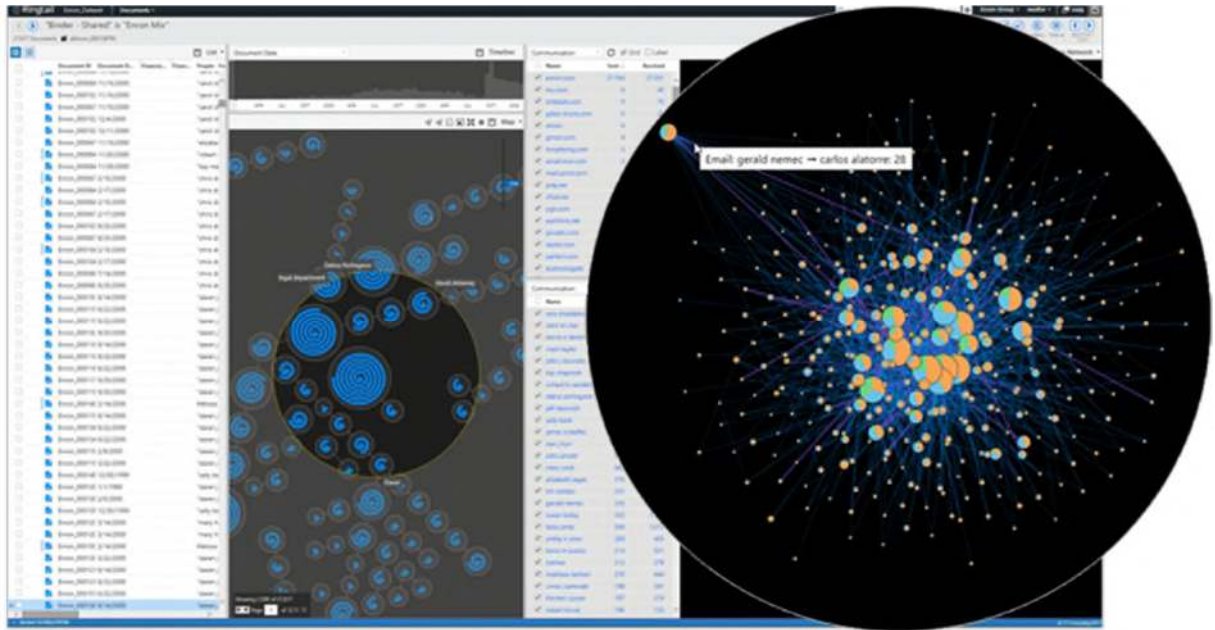

Feature Highlight: Email Threading

Designed to help legal teams parse e-mail conversations quickly and accurately without reading duplicate passages of text, Ringtail's new e-mail threading feature is comprehensive, but easy to use. Reviewers will be able to scan long threads and identify the unique parts of each e-mail, see pivots where new threads begin and see where attachments or people are dropped or added to a unique conversation. And because e-mail threading is controlled during the processing phase, legal teams can deploy threading analysis on a case by case basis.

		Document Title	Thread Data	Document ID
1	2 1	Raptor 2 hedge		F00210-E0001-00474870
2	5 2	ESAraptor2.doc		F00210-E0001-00474871
3	4 1	Raptor 2 hedge		F00210-E0001-00474874
4	5 2	ESAraptor2.doc		F00210-E0001-00474875
5	6 1	Re: Raptor 2 hedge		F00210-E0001-00479282
6	5 2	ESAraptor2.doc		F00210-E0001-00479283
7	8 1	Re: Raptor 2 hedge		F00210-E0001-00474878
8	5 2	ESAraptor2.doc		F00210-E0001-00474879
9	2 1	ESAraptor2R.doc		F00210-E0001-00474880

Feature Highlight: Predictive Coding and Continuous Active Learning

Ringtail's Predictive Coding uses machine learning to analyse the human review of controlled samples and then applies the resulting knowledge to very large sets of documents. The offering leverages Ringtail-developed workflow and software, including random sampling, template driven model training, document scoring, cross-fold early performance indicators, recall/precision reporting, validation reporting and coding application, and leverages an open source machine learning library supported by Microsoft Research Labs.

Ringtail's unique, visual approach to all phases of the predictive coding process reduces the complexity associated with technology-assisted review. Ringtail

dynamically visualizes precision and recall levels so legal teams can align their review



goals with the budget and importance of the project.

Collection

Nuix Enterprise Collection Center (ECC) is a standalone tool that is also part of the Nuix eDiscovery solution. Nuix ECC streamlines the collection process with the following features:

- Automate repetitive tasks with email alerts, reports, and logs about the state of collections
- Avoid collection failures due to network dropouts, with fault tolerance and the ability to resume incomplete disk images and relocations
- Schedule recurring collections and multi-job sequences
- Remotely execute commands on target computers
- Securely move or copy files between devices on the same network, across the firewall, and even in the cloud

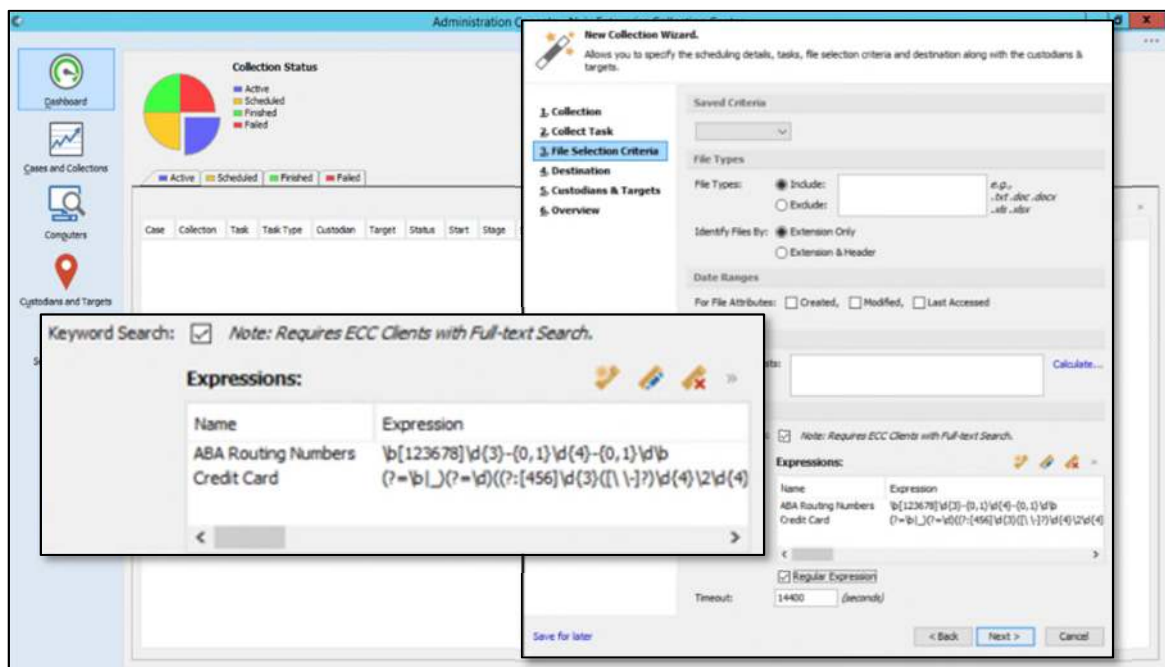

Legal Hold

Nuix Legal Hold is a standalone tool that is also part of the Nuix eDiscovery solution. With Legal Hold, organizations can build automation and simplicity into required preservation processes.

Nuix Legal Hold replaces inefficient, ad-hoc processes for holds and notifications, processes that cost time, money, and peace of mind.

- Connects to enterprise systems, including matter management, content, and human resources information systems, to manage potential custodians and act when certain conditions are met
- Workflows can be automated for maximum efficiency and accuracy
- Equipped with pre-made notice templates, but provides the option for organizations to create their own notices including data merges

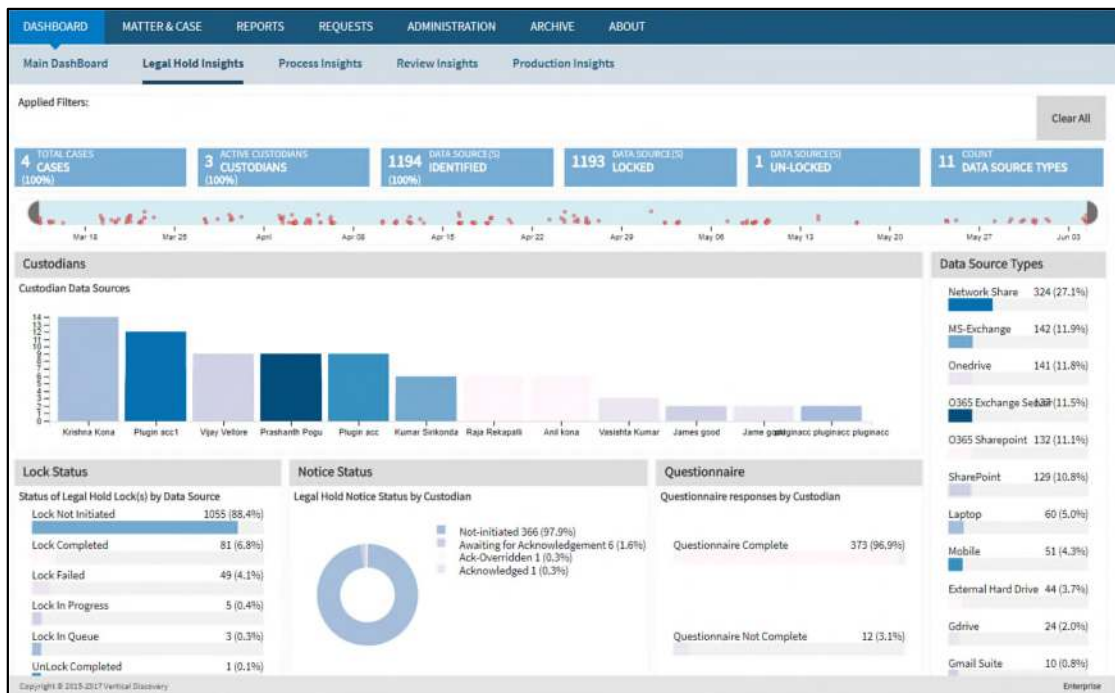

- Collects and compiles data on organizational processes as it goes, helping the organization understand the costs of collected data for key employees and better inform business decisions and formation of best practices

Owned/Supplied by :	Nuix
Used by :	7Safe, Altlaw, A&M, Anexsys, Aon, Consilio, CYFOR, Deloitte, Epiq, Ernst & Young, FRA, Forexus, Grant Thornton, IDS-Legal, Inventus, KPMG, Legastat, Lighthouse, Omnis, PwC.

8.2.52 OpenText Discovery Suite (Encase & Axcelerate)

OpenText Encase was acquired by OpenText and now complements Axcelerate's robust enterprise integrations with the most widely used forensic collection agent, deployed on over 36 million endpoints and counting. The EnCase agent enables legal ops to collect data from laptops, desktops, phones, and more with a lightweight agent. In addition to workstations, laptops, and mobile devices, Encase can also collect and preserve content from on premise data repositories like Microsoft Exchange, Sharepoint, and Lotus Notes or from cloud data repositories like Amazon S3, Box, Google Drive, Dropbox, and Office 365.



Figure 1: OpenText Encase, collection wizard

Encase can target specific files or capture whole disks, discretely. It can operate in the background and maintain a collection process even when a user goes offline. As soon as they reconnect, the agent resumes and completes the collection. This data is captured in EnCase's Logical Evidence File (LEF) format, ready for ingestion into Axcelerate or any other review & analysis platform.

OpenText Axcelerate is a complete, end-to-end eDisclosure platform featuring best-in-industry collections, analytics, and Predictive Coding delivered in an unparalleled user experience. From legal hold, to ECA and collection, to analysis, review, and productions, Axcelerate is the trusted choice for premier corporations, law firms, and government entities across the EU and the US.

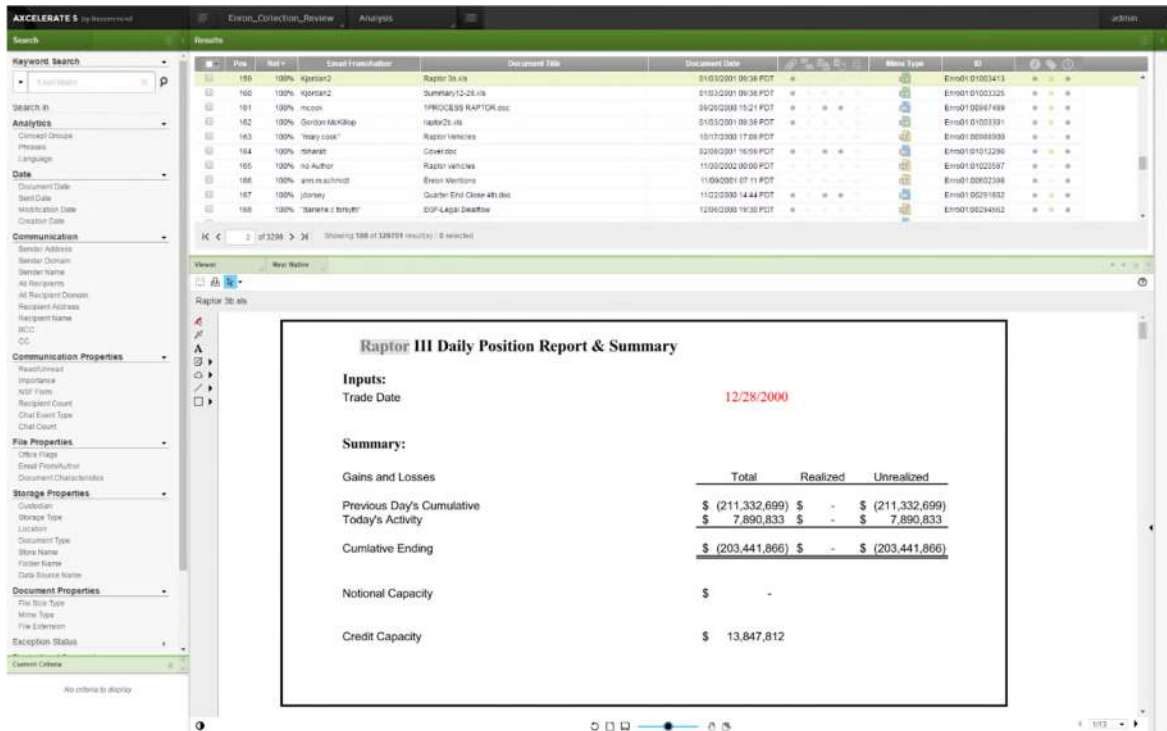

Figure 2: OpenText Accelerate, document viewer

The OpenText Accelerate platform includes 2 seamlessly integrated modules:

Accelerate ECA & Collection tackles early stage/pre-action stage of eDiscovery—identification, preservation, collection, and processing—in a single, highly scalable application. It enables organisations to connect to laptops, desktops, file shares, email servers, and document and records management systems to “explore-in-place” down to the file level, indexing data for search and aggressive culling before collection. Axcelerate crawls and directly ingests native file types from a wide range of cloud and on-premise sources, including Microsoft Office 365, Microsoft Office, Lotus Notes email, web-based email (Gmail, Outlook.com, Yahoo), ‘chat’ communications (Bloomberg, WhatsApp, Slack), and over 400 additional file types, all with automatic language detection.

Accelerate Review and Analysis empowers legal teams to find the documents that make or break their cases, faster and more reliably. Axcelerate was named “Best eDiscovery Review Platform” by the editors of Legaltech News (June 2015) on the strength of its advanced analytics, best-in-industry Predictive Coding, and consumer-grade user experience.

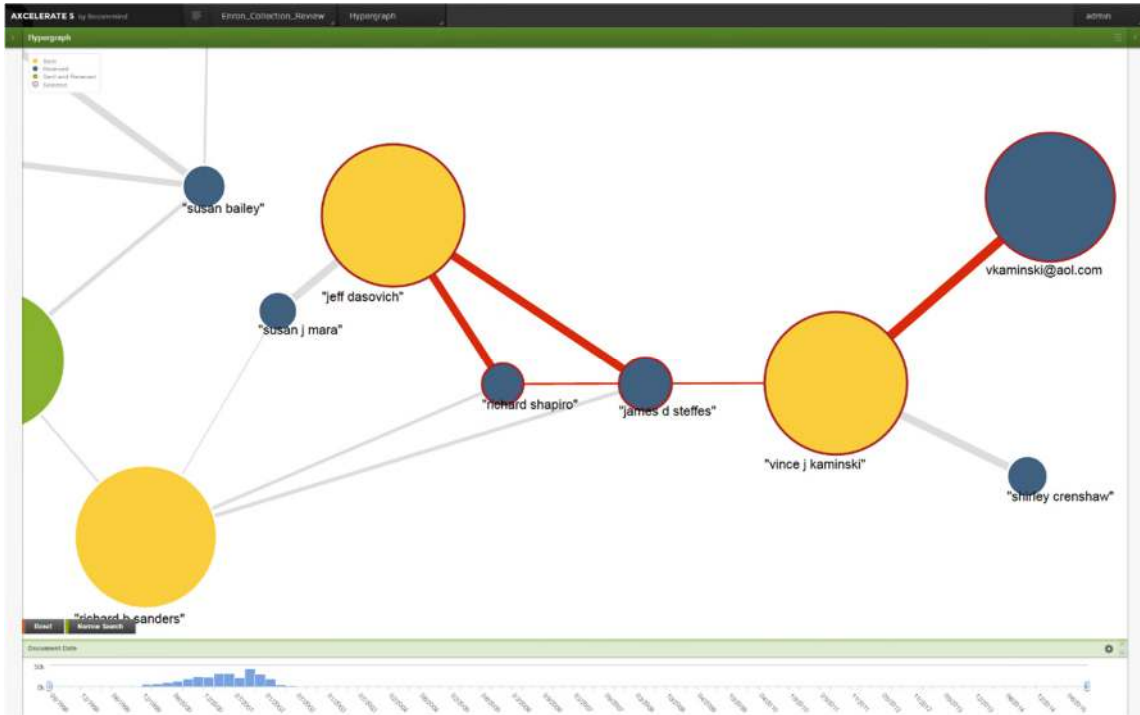

Figure 3: OpenText Axcelerate, communications analysis

Axcelerate is delivered self-service to full-service to anywhere in between, as a subscription-based cloud solution, an “on-demand” hosted solution, or an on-premise software solution. Unlike other platforms that depend extensively on third party components and scripting, Axcelerate is a complete solution including self-standing productions, proprietary advanced analytics, and interactive visualisations no other solution has, all built right in:

- **Super-fast search** using various approaches including stem, fuzzy and concept searching to get results fast.
- **Smart Filters** to find the top people, search terms/phrase and data points quickly and easily, no need for complex search strings.
- **Hypergraph** communications mapping for visualised analysis of email and chat data at the sender and domain level.
- **Phrase Extraction** for more sophisticated keyword searching that shows terms in context.
- **End-of-Branch Email Analysis** for easy-to-follow threading and automatic identification of missing messages.
- **Continuous Machine Learning** for flexible, issue-specific Predictive Coding review workflows with superior results and simpler protocols.
- **Concept Browser** for automated categorisation and organisation of unstructured data into conceptually related clusters ready for investigation.
- **Smart Redactions** for automatic reaction of PII, PCI, and other patterns across entire data sets or on-the-fly during review without pre-imaging.
- **Business Intelligence with Efficiency Scoring** for total visibility into discovery processes at a project level and across the entire case portfolio.



Figure 4: OpenText Axcelerate, phrase Smart Filter

Chapter 8 – Supplier & Software Details

Axcelerate is backed by OpenText's world-class support and professional services teams across the EU and US for training and processing.

Owned/Supplied by :	OpenText
Used by :	AlixPartners, CAS, Deloitte, eMag Solutions Forexus,

8.2.53 Relativity

RelativityOne Overview

Whether it's litigation, information governance, a government request, or an internal investigation, RelativityOne gives you a complete set of flexible tools in a secure cloud platform to tackle your unique challenges through every phase of a project.

Keep Your Data Safe – Centralise your data and reduce risk with a SaaS solution backed by Relativity Trust, a security program that goes far beyond standard data security and privacy certifications. With preventative defense, automated processes, and transparent operations, RelativityOne keeps customers' most sensitive data protected.

Leverage Cloud Elasticity – Don't worry about maintaining infrastructure or keeping up performance during peak times – it's all covered by RelativityOne.

Use a Single Solution – Start and finish e-disclosure in one solution with a single audit trail. No risky data transfers required.

Support e-Disclosure around the World – RelativityOne is available in the US, UK, Hong Kong, Canada, Brazil, and the Netherlands.

Built on Microsoft Azure - Benefit from the scalability, redundancy, and international reach of the Microsoft Azure cloud, as well as the continual investment, innovation, and commitment to [security](#) Microsoft puts into it.

Integrate with Microsoft Office 365® - Seamlessly move data from Office 365 to RelativityOne to get your review up and running quickly.

Capabilities

Legal Hold – Fully integrated into Relativity, Legal Hold is a simple solution for a complex enterprise challenge that enables you to create a defensible, repeatable process for managing legal holds. Streamlined and automated workflows mean any team – legal, IT, or HR – can run their unique legal hold processes in Relativity. Additionally, every correspondence can be created from scratch, or built using existing templates, while built-in reports and dashboards provide real-time insight.

Collection – For legal teams and e-discovery professionals who want to quickly and securely get data from the cloud into review, RelativityOne Collection enables you to pull data from Office 365 directly into RelativityOne. With most enterprise data stored in Office 365, Collection makes it seamless and secure to get the most critical data into reviewers' hands as soon as possible.

Processing – Relativity Processing is tightly integrated into RelativityOne, so you can process and review data without ever leaving the system. An inventory option provides quick insight into your data and allows you to remove irrelevant files based on a date range, sender domain, and other high-level filters prior to fully processing documents for review. Reports, email notifications, and real-time status updates provide complete visibility into your processing job.

ECA & Investigation – Leverage a repository workspace to complete early case assessment and store coding decisions – all at a discounted rate. This workspace helps you streamline the process of understanding and culling data, providing only the functionality required to process collected data in a single searchable workspace, and start applying parameters to identify documents relevant for review.

Review & Productions – RelativityOne allows you to tackle all document review and production challenges, from the smallest to the most complex projects. Everything that you need to move from review to production can be found within a single platform. One of the latest capabilities is short message review. As the way people communicates has shifted toward more texting, instant messaging, collaboration tools, and social

Chapter 8 – Supplier & Software Details

platforms, Relativity has developed the Relativity Short Message Format to help you seamlessly review, analyse, and produce short message data from SMS, MMS, iMessage, Slack, Skype, Bloomberg, and other sources. This provides a holistic view of communications across multiple channels – critical to understanding the entirety of dialogue between individuals involved in a matter.

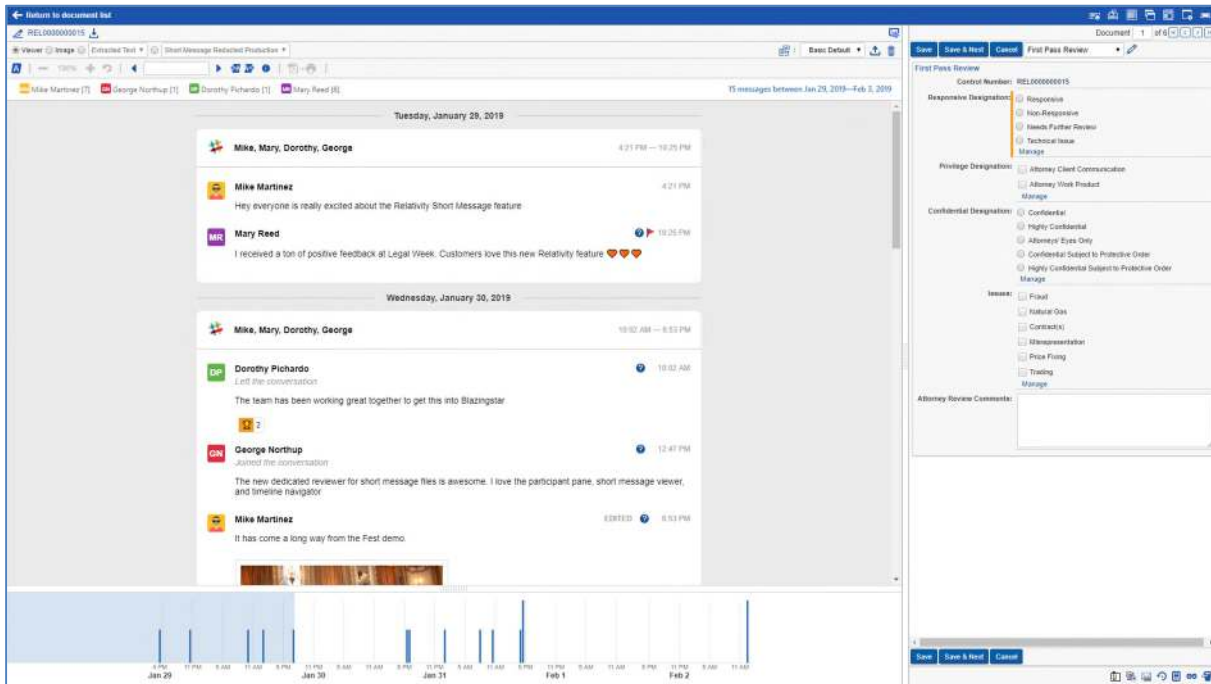

Short Message Review

Analytics & Assisted Review – Relativity Analytics and Assisted Review amplifies your e-disclosure efforts with visual data analytics and machine learning technology. You can bring in analytics at any time in your project, from early case assessment through production. Proven effective by hundreds of organizations and approved by courts across the globe, Relativity Analytics empowers you to investigate and review data faster with the control and flexibility you need to do it accurately and defensibly.

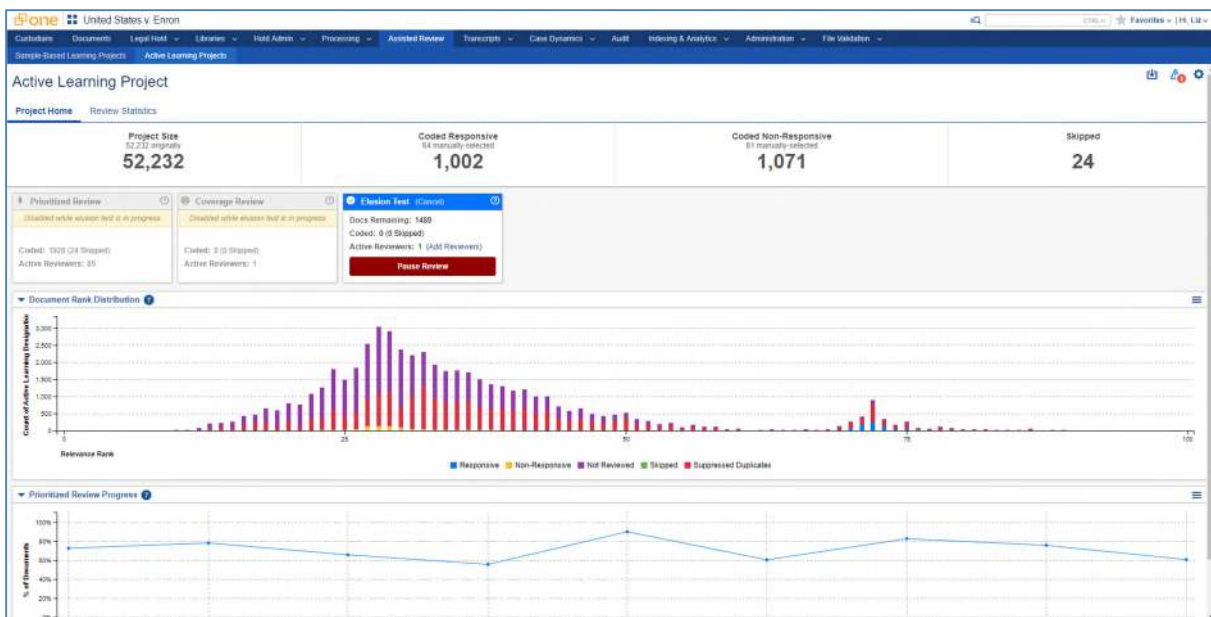

Active Learning

Chapter 8 – Supplier & Software Details

Case Strategy – With Case Dynamics, you can manage your case strategy from a single location, alongside your e-disclosure efforts, to stay organized and focus on finding the truth. A complete toolset lets you share findings with your e-disclosure team and adapt your approach as you uncover the facts, making it easy to build your strategy through the entire case lifecycle. The latest capability added to help with case strategy, transcripts, is an application in Relativity to upload, review, and take action on transcripts to better prepare for trial.

View	Add Child	Fact	Description	Date Type	Primary Fact Date	End Date
<input type="checkbox"/>	<input type="checkbox"/>	<input type="checkbox"/>	Kenneth Lay and Jeffrey Skilling announced to analysts that they were going to open trading for their own high-speed fiber-optic networks that form the backbone for Internet traffic	On	10/5/1999 12:00 AM	
<input type="checkbox"/>	<input type="checkbox"/>	<input type="checkbox"/>	Analysts have mixed feedback on this announcement.	On	11/1/1999 12:00 AM	
<input type="checkbox"/>	<input type="checkbox"/>	<input type="checkbox"/>	Fastow began establishing numerous limited liability special purpose entities	Between	8/16/1997 12:00 AM	9/14/1998 07:00 PM
<input type="checkbox"/>	<input type="checkbox"/>	<input type="checkbox"/>	Creation of JEDI and Chewco	On	9/1/1997 12:00 AM	
<input type="checkbox"/>	<input type="checkbox"/>	<input type="checkbox"/>	Creation of Whitewing	On	12/1/1997 12:00 AM	
<input type="checkbox"/>	<input type="checkbox"/>	<input type="checkbox"/>	Creation of LJM and Raptors	On	2/19/1998 12:00 AM	
<input type="checkbox"/>	<input type="checkbox"/>	<input type="checkbox"/>	Enron's stock lost one-third of its value	Around	6/1/1997 12:00 PM	
<input type="checkbox"/>	<input type="checkbox"/>	<input type="checkbox"/>	Enron's executives' performance-based bonuses were slashed	Around	7/1/1997 12:00 PM	

Case Dynamics

Owned/Supplied by :	Relativity
Used by :	7Safe, AlixPartners, Altlaw, Aon, A&M, Anexsys, BDO, Consilio, CYFOR, Deloitte, DTI, Epiq, Ernst & Young, FRA, Forexus, Grant Thornton, Integreon, Inventus, KLDiscovery, LDM Global, Lighthouse eDiscovery, LINEAL, London Legal, Navigant, PwC, QuisLex, TransPerfect Legal Solutions, XLS.

(29 organisations)

8.2.54 Reveal Software

eDiscovery, fast and flexible.

Reveal organises the world’s legal data, making it more accessible, predictable, and affordable for our clients through an end-to-end software application.

We deliver better answers from your data, faster.

Easy-to-use interface reduces time and frustration

Reveal users experience productivity with minimal training on Day One. Visual cues throughout the user interface help you identify and work within the software quickly and easily.

In addition, Reveal is supported directly by its developers, so your support questions and feature requests will always have a direct line to the developers themselves.

Global Footprint

We understand that flexibility is key. Reveal is available to our clients in a SaaS environment, on-premises, or in a hybrid model, depending on your use case.

For those spinning up instances around the globe, our SaaS instances are an ideal solution. We provide the ability to quickly and automatically offload data to secure, less expensive cloud storage, reducing your data storage hosting fees.

Today, we can quickly spin up Reveal instances in 40 countries on six continents, with more data centers in the works.

Features and Services

- | | |
|--|--|
| <ul style="list-style-type: none"> • Full-featured production • Elasticsearch • Intuitive design • User-defined workflows • Assisted review • Data preview • Multi-language availability • Global SaaS infrastructure • Supported in all major browsers • Robust API • Reveal Analytics • Data locality (GDPR) • On-premise option • Activity reporting • Drag & drop layout • Column filtering • Document review | <ul style="list-style-type: none"> • Near-dupe and de-dupe • Rapid release dev cycle • Scalable search functionality • Rule-based production and QC • Collaborative review • User-level permissions • Matter assignment • Transcript manager • Hit reports feature • Case management • Intelligence panels • Filtered views • Multi-factor authentication • Document-level security • Fuzzy search • Metadata management • 24/7 support |
|--|--|

Owned/Supplied by :	Reveal
Used by :	Reveal

8.2.55 Servient

Servient – Processing, Analytics, Document Review and Production Platform

Servient is a powerful eDiscovery platform that was designed and architected for the cloud, incorporating the most advanced software available to provide a truly scalable experience.

Built on AWS (Amazon Web Services), users will benefit from the vast scalability, redundancy, and international availability of the AWS cloud, meaning that data can not only be processed in extremely fast time scales, but also within the region in which it was created (very useful for certain projects, and with GDPR in mind).

The Servient dashboard gives quick access to the main aspects of the system:

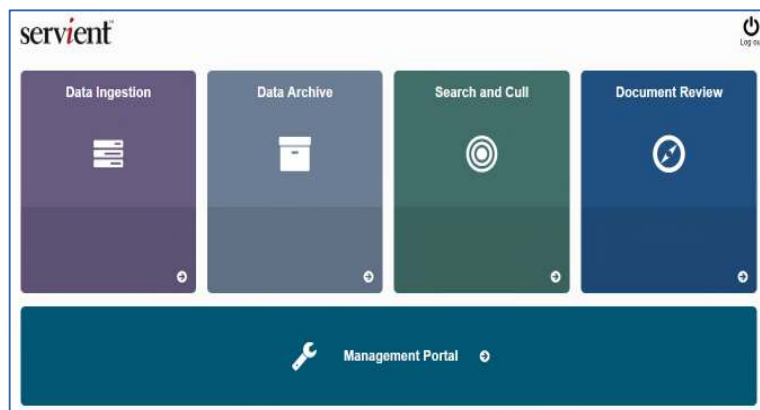

Processing is fast and comprehensive, but designed with 'self service' in mind. Users, without any assistance from Servient, can process any amount of data securely. Of course, if you would like some assistance, Servient is glad to help with any processing job.

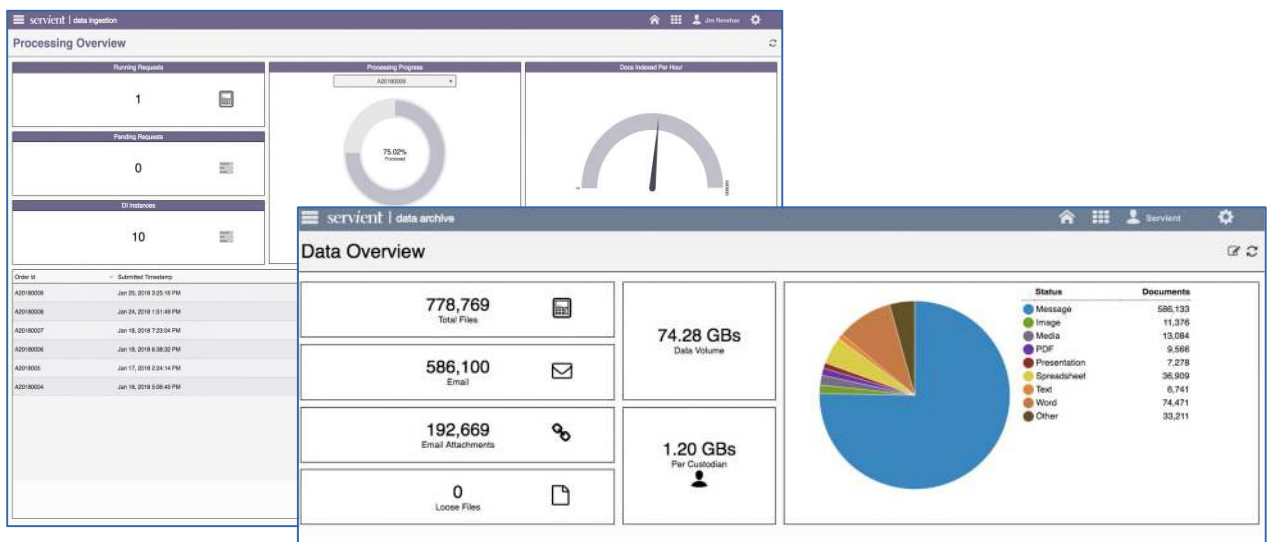

Chapter 8 – Supplier & Software Details

Searching is provided for by both 'Standard' and 'Analytic' methods

- Standard searching & Filtering - Keywords, phrases, date range, format, custodian, boolean etc
- Analytical searching – Advanced Technologies such as Continuous Active Learning (Technology Assisted Review / Predictive Coding), concept searching, clustering, email threading

The image displays four screenshots of the Servient Document Review software interface, illustrating various search and analysis features.

Top Left: Quick Search
This panel shows search filters for a case named 'LondonTech'. It includes fields for 'Full Text' (containing 'cash'), 'Doc ID', ' Bates' (with Prefix, Number, and Suffix sub-fields), 'Responsive' (set to 'All'), 'Revised' (set to 'All'), 'Privilege' (set to 'All'), and 'Confidential' (set to 'All'). There are also date range filters for 'Profile Date' and 'Specific Date', and a 'Tags' field. Search and Clear buttons are at the bottom.

Top Right: Search Results
This panel shows a sunburst chart representing search results. The central node is 'mid-c calendar' with a count of 14,422. Other nodes include 'report file', 'portation system', 'action file', 'vehicle transportation', 'energy', 'tax', 'bond', 'exchange', 'commodit*', 'sale', 'auction', 'offerings', 'energy', 'asset', 'securities', 'deal', 'liability', 'stock*', and 'tax'. A word cloud on the right lists terms like 'christian', 'pandax', 'reproduction', 'shown', 'skeptical', 'electric ca.', 'mky', 'year', 'to rulemaking', 'low nox', 'been', 'puc', 'erratic power', 'mid-c calendar', 'choice power', 'mexico', 'ug', 'pala', 'gasberia', 'resources', 'ing', 'insolvency', and 'tax change'.

Bottom Left: Initial Key Words
This panel displays a grid of key words with their respective counts. The total results are 16,060. The words and counts are: deal (4,061), liability (3,780), stock* (3,293), tax (3,378), bond (1,108), securities (3,005), auction (1,388), sale (3,341), commodit* (4,422), exchange (4,884), asset (3,207), offerings (207), and energy (8,608). Buttons for 'Add', 'Delete', 'Activate', 'Deactivate', and 'Generate Report' are at the bottom.

Bottom Right: Learning Statistics
This panel shows a bar chart of 'Learning Model History' with a y-axis from 0 to 14,988 and an x-axis from 0.00 to 1.00. The chart is divided into segments for 'Response', 'Neutral', and 'Non-Response'. A table below the chart shows the document counts for each category:

Bucket	Document Count
Highly Responsive	5,202
Likely Responsive	5,740
Neutral	6,929
Likely Nonresponsive	8,999
Highly Nonresponsive	20,474

Chapter 8 – Supplier & Software Details

Document Review is easily set up in Servient, whether for small straightforward cases or for multi-level reviews. Batching of documents to the reviewers is automatic, faceting allows for point & click searching, up to the second reporting, and allows the legal team to begin work immediately. The coding/tagging panels are easily modified to fit your matter requirements or customisable to match your internal corporate systems.

The screenshot displays the Servient Document Review interface. At the top, it shows the case name "Case: LondonTech" and the user "Ben". The main area is divided into several sections:

- Facet Category:** A sidebar on the left showing a hierarchical tree of metadata filters such as Custodian, Date, Domain, and Email Address.
- Documents:** A central table listing 19 documents found. The table has columns for Details, Profile Date, Profile Sender, Profile Recipients, Subject / Filename, and Action. The first few rows show documents with IDs like 0000533, 0001102, and 0001732.
- Document Viewer:** A window showing the content of a selected document, which is an email. The email header includes "From: Malincamp Lisa <Lisa.Malincamp@ENRICH.com>", "Sent: Friday, December 26, 2001 1:22 AM", and "Subject: RE: Requests for return of cash collected". The body of the email discusses a proof of claim and a cash collection.
- Document Editor:** A window showing a document titled "ASSIGNMENT AND ASSUMPTION AGREEMENT". The text of the agreement is visible, including the parties involved (Enron North America Corp., Enron Credit, Inc., and Bear Stearns & Co. Inc.) and the effective date of the agreement.

Chapter 8 – Supplier & Software Details

Reporting, Analysis and Productions are easily managed through a series of easy to use dashboards, allowing your team to quickly see what has taken place during each stage of the review. In addition, Servient has a full slate of Quality Control dashboards that tracks each reviewer, how many documents they have reviewed, and most importantly, how accurate they are.

We then allow the manager to check the documents that the reviewers have coded incorrectly. In addition, Servient provides Sampling Dashboards to validate the quality of the review. The Production template provides easy to follow instructions to allow for the quick completion of your productions.

The image displays several screenshots of the Servient document review software interface:

- Reviewer Productivity:** A dashboard featuring a circular gauge showing a score of 17.49. Below it is a table of reviewer statistics:

Reviewer	Total	31-03-2018	31-03-2019	31-03-20
George Washington	1,808	0	0	0
Harry Truman	0	0	0	0
James Madison	331	0	0	0
Jim Roosevelt	38	0	0	0
John Marshall	0	0	0	0
Special Support	370	0	0	0
Taylor Madison	0	0	0	0
Thomas Jefferson	208	0	0	0
- Review Statistics:** A dashboard with a 'Data Volume' table and a 'Current Review Status' pie chart.

Description	Count	Size(GB)
Total Documents	163,703	17,667
Total Thread Children	8,799	1,408
Total Top of Threads	6,868	1,633
Total Loose Files	0	0
Total Email Attachments	107,188	8,326
Total Email	56,515	9,277
- Review History:** A table showing document review activity over time:

Category	Documents	Latest Manual Calls	Documents	All Batch Assign Calls	Documents	Latest Batch Assign Calls	Documents
Today	0	Today	0	Today	0	Today	0
Yesterday	0	Yesterday	0	Yesterday	0	Yesterday	0
This Week	0	This Week	0	This Week	0	This Week	0
This Month	5	This Month	0	This Month	0	This Month	0
This Year	1,377	This Year	1,214	This Year	402	This Year	201
			1,214		402		201
			356		178,373		97,320
- Edit Production Template:** A configuration screen for production templates, showing 'Stamp Settings' and 'Load File Settings'.
- Delimiters:** A configuration screen for delimiters, showing settings for Type (Concordance), Column (9 (020)), Quote (p (254)), Newline (␣ (174)), Multi-Value (: (059)), Image Load (OPT, LFP), and Date/Time (Date Format: MM/DD/YYYY, Time Format: HH:MM:SS [24 HOUR], No Date Value: Null [Value]).

Chapter 8 – Supplier & Software Details

The Servient system is designed to allow legal reviewers to quickly navigate through the matter documentation, but importantly is also designed to allow team leaders (or litigation support, knowledge lawyer, PSL) to take control of all aspects of the system as required, without the need for long and time-consuming training, giving the legal team full flexibility and control of the matter workflow.

The Servient system is designed to be faster, more accurate and less expensive than any other system on the market

Owned/Supplied by :	Servient
Used by :	Linklaters, Servient.

8.2.56 Sightline (From Consilio)

Sightline is a secure, web-based document review platform designed and built by Consilio’s in-house development team to meet the challenges of complex eDisclosure exercises. Sightline is hosted in Consilio data centres across the globe to aid compliance with local data privacy restrictions.

The platform supports both small and large scale document review exercises and offers a range of features designed to simplify and speed up the review process, by as much as 40% (as measured in empirical tests by Consilio)*. Sightline’s automated optimised sorting of records, leverage of analytics, intuitive and customisable review interfaces, and automated workflow-management tools all improve review speeds over other software.

Users have the ability to perform simple or complex searches, create tags and folders, apply redactions, highlights, reviewer remarks and comments to documents, and select groups of documents for review and production. Sightline allows searching and review of electronic documents in any language.

Using dynamic visuals such as widgets, dashboards, timelines and enhanced statistics, review managers can gauge resource requirements, monitor review progress, track reviewer productivity and adjust workflow to meet deadlines - all of which can be automatically sent to selected email addresses as scheduled reports.

Consilio maintains multiple Best in Service Blue™ data centres in Europe.

Analytics, Artificial Intelligence and Technology Assisted Review

Provided as standard (at no extra charge) with every matter hosted in Sightline, its advanced analytical technology identifies near-duplicate and conceptually similar documents, generates email threads and communication maps, provides concept searching, clustering and categorisation, and leverages artificial intelligence to enable lawyers to prioritise and review documents more efficiently..

Consilio also offers clients a fully supported predictive coding solution as a cost- and time-efficient alternative to manual human review. The technology can create and optimise multiple predictive coding models concurrently within the same review process, thus allowing more granular and/or issue based review. Each predictive model (tag specific) is independent of any others; thus each document will receive a probability score from each predictive model generated. The technology also handles sets of documents in multiple languages without the need to create separate workflows. Consilio project managers support clients throughout each stage of the predictive coding process ensuring that results are defensible and repeatable.

Enhanced Audio Review in Sightline

Sightline fully integrates Nexidia’s world-leading, patented phonetic indexing and search technology to allow the searching, review and redacting of audio files, such as telephone conversations, in the same platform as the rest of the review material. This streamlined one system approach delivers dramatic improvements in accuracy and the opportunity for significant cost reduction.

Owned/Supplied by :	Consilio
Used by :	Consilio

8.2.57 SPEKTOR Suite

SPEKTOR® Forensic Intelligence

A fully integrated hardware and software solution that enables non-technical first responders and litigation support teams to perform the following tasks quickly and safely:

DATA ACQUISITION

- Collect, forensically preserve & analyses data from computers (PC, MAC, Linux) , hard disks, removable media, cell phones, Sat phones , GPS and tablet devices
- Creates forensic images in dd, ENCASE®, FTK®, SMART® formats
- Live incident response including volatile data preservation on Windows (32bit and 64bit)
- Process driven, touch screen interface. Fully audited. Forensically & evidentially sound.
- Collect from “running” and “powered off” systems. Collect live and deleted data
- Quickly create and store unlimited re-usable collection profiles using our unique 6 step profile wizard.
- Collect data based on file dates, types and/or content using powerful signature analysis
- Allow remote data custodians to preserve their own data using secure collector technology
- Simultaneous collections from an unlimited number of devices
- Everything in one box - all hardware, software, accessories and peripherals are included.

DATA ANALYSIS

- Auto-analysis and easy review of email, images, documents, movies, audio, system registry, browser activity, social media, chat, IRC, volatile network data, recent activity, system users, attached device history, installed software, network configurations.
- Recovers online chat and web browsing account details including passwords, online search term history, file transfers. Reconstructs webpages visited by users.
- Very powerful filtering and sorting using a simple interface – find interesting data faster
- Instant keyword searching: Full indexing of file names, paths, file content and file metadata.
- Instantly locates valid bank card numbers found in any collected data
- Store unlimited keyword lists with unlimited number of keywords
- Search in multiple languages using keyword lists or the onscreen keyboard
- Find known files using unlimited hash values – every collected file is hashed with MD5 & SHA1
- Quickly import and store unlimited numbers of hash lists, each with unlimited number of hashes

Chapter 8 – Supplier & Software Details

- Auto identifies high risk files such as those with incorrect or missing file extensions, encryption, steganography and known indecent images or terrorist materials
- Powerful reporting to PDF or HTML
- Easily export to 3rd party review, visualisation and decision support platforms

SPEKTOR Forensic Intelligence software is supplied with all the required hardware and peripherals in a small rugged hand carry case ready for instant deployment.

SPEKTOR® Drive

The Pocket Forensic Lab™ - The same outstanding capabilities as SPEKTOR® Forensic Intelligence* on a bootable thumb drive that runs on any compatible PC platform, temporarily turning it into a powerful forensic workstation. An invaluable pocket sized incident response tool for compliance, e-discovery and security professionals.

** excludes the mobile phone module*

Owned/Supplied by :	ETL
Used by :	ETL

8.2.58 StoredIQ for Legal (IBM)

Help eliminate complexity, pain and expense from the eDiscovery process

Highlights

- Notify custodians of legal hold obligations with automated legal holds, alerts and reminders
- Manage custodian interviews/surveys to gain insight into the most relevant custodians and data sources for a matter
- Analyse data in place to gain insight into the scope and merits of a matter before collection
- Reduce downstream review costs by performing early data assessment and culling prior to export
- Automate the legal collection process from more than 100 data sources
- Align IT and legal so they speak the same language about what information needs to be collected, where and by when
- Deliver a repeatable and defensible eDiscovery process

Legal teams must wade through a rising tide of information to discover what is relevant for a specific legal matter. By targeting only the information that is most important, these teams can reduce the cost, risk and time involved in an eDiscovery response. IBM StoredIQ for Legal provides robust management of the eDiscovery process, from hold notification to identification, preservation and collection.

StoredIQ for Legal enables legal teams to efficiently and confidently manage the full matter lifecycle and process compliance for thousands of matters. It allows legal teams to issue custodian hold notices and interviews with automatic follow-ups and escalations, manage preservation and collection activities conducted by IT, and find and analyse unstructured information in place to gain faster insight into data and help ensure only the right information is collected. Legal teams can save time and gain flexibility by not having to move data before analysis. They can take action on data before collection, acquiring insights from data in a matter of hours versus weeks and using that knowledge to make more informed business decisions. Legal teams can also perform both proactive and reactive eDiscovery processes.

Streamline management of the full matter lifecycle

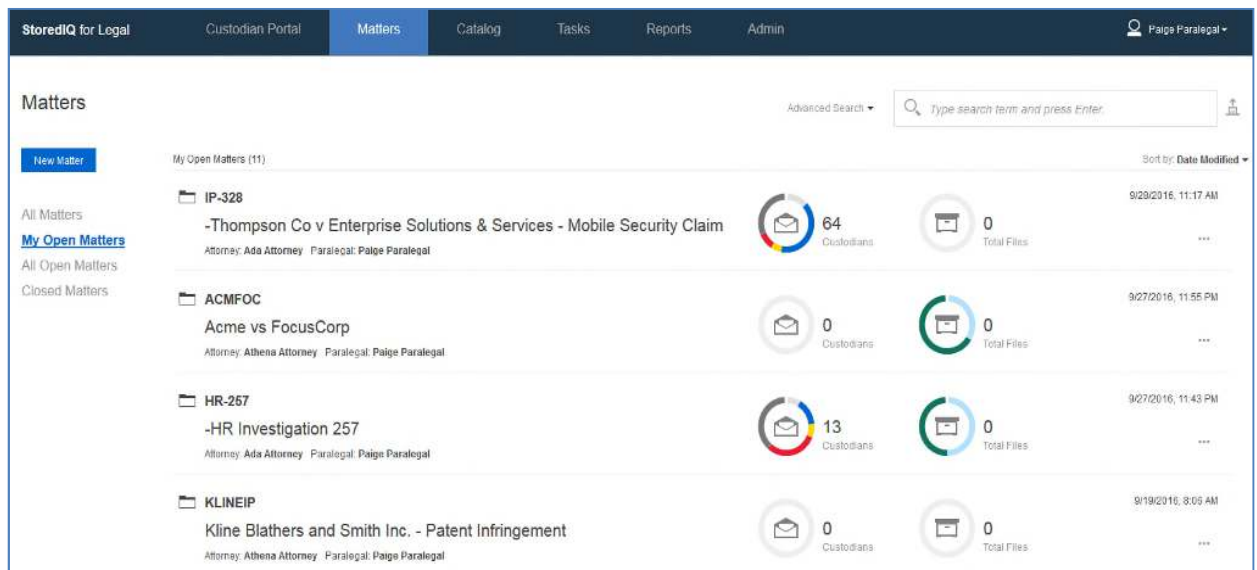

Teams begin to realize the benefits of StoredIQ for Legal through the legal hold notification process. The solution helps reduce the preservation risk from lack of process integrity, minimize manual mistakes and eliminate common legal hold notification oversights. With StoredIQ for Legal, team members can easily identify custodians and draft legal hold notices by drawing on templates. They can send those notices, conduct custodian interviews, solicit approvals and track custodian responses from easily configurable dashboards. They can then schedule and automatically send reminders to custodians (including a consolidated reminder) about their ongoing duty to preserve, escalate non-responders to their manager and rapidly move from notification to sending preservation or collection requests to IT—all from the same interface.

If the reason for the hold turns into a formal legal matter, StoredIQ for Legal can streamline a variety of tasks for IT and non-IT users. For example, the solution helps IT users oversee the identification, collection and preservation of all physical and electronic data relevant to the matter. Those IT users can execute the business and technical processes as well as the communications needed to preserve data in an approved manner. Non-IT users can easily send role-appropriate alerts, set action items and produce reports.

Enhance the efficiency of eDiscovery management

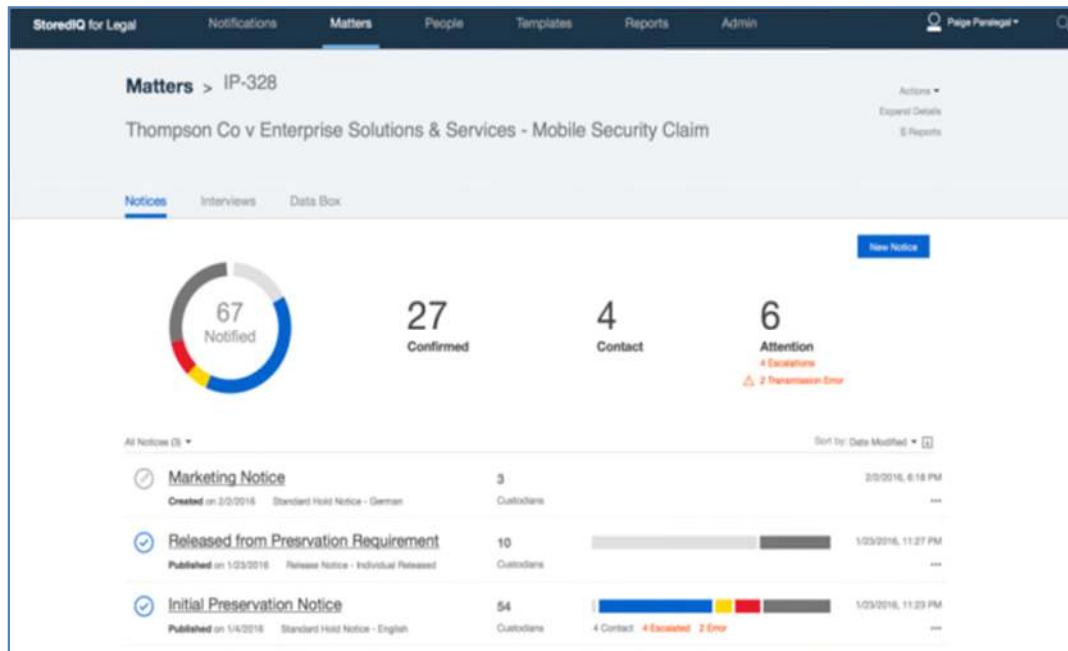

StoredIQ for Legal Notifications provides legal staff an interface to manage hold notice notifications and conduct virtual interviews:

- Reliably send legal hold notices and track responses across thousands of matters
- Automatically send reminders to custodians (including a consolidated reminder) and escalate non-responders
- Send interviews and manage responses with automatically generated follow-ups
- Manage by exception and utilize workflows to track approvals and follow-ups

StoredIQ for Legal Identification and Collection offers several capabilities to help legal teams manage the eDiscovery collection process and reduce cost, complexity and common collection inefficiencies:

- Manage eDiscovery collections from more than 100 common data sources
- Identify and analyse data in place before collection, helping to save costs and reduce risk by amassing only required content
- Set collection criteria once and apply everywhere
- Identify and collect content in file shares, user desktops, email systems, archives, content management systems, collaboration systems, Microsoft SharePoint and more
- Track collection status and provide clarification throughout the process
- Export collected content and original metadata to major review tools

StoredIQ for Legal Identification and Collection helps IT and data experts:

- Receive and manage preservation and collection requests directly from legal in the same solution
- Find relevant content by metadata or full-text searches, or classify data with machine learning
- Access desktop and laptop data across large installations, with support for agent or agentless collection and full start and stop capabilities in a purpose-built, desktop collection interface
- Identify over 450 content types, including nested content in containers such as ZIP, PST and NSF
- Analyse content in-place before collection to cull large data sets into manageable collections
- Manage exceptions in an easy-to-use exception centre that supports the ability to retry and reroute exception content
- Provide collection status or ask for clarification from legal, all in the same interface
- Export collected content and original metadata to major review tools

Data Box

Refine and collect from SharePoint for HR-257
[Expand Details](#) Last saved: 12/13/2016, 11:32 PM

Request Criteria

Custodians

Describe the data to be identified.

Data locale * Select at least one data locale.

Content repositories: Content repositories

File shares: Corporate file servers and repositories

Desktops: Custodian Workstations and Laptops

Email: Outlook and Notes servers

Collaboration: Group shares, such as SharePoint or wikis

Cloud: Content inn Box Cloud accounts

Date range If you do not specify a date, data up to the current date is searched.

Start date: End date:

Type * Select the ones that fit the selected data locales.

Email: Outlook, Notes

From To CC BCC

Word processing: Word, text, PDF, RTF

Multimedia: Animation, sound, music

Presentation: PowerPoint

System files: Configuration

Miscellaneous: Others

Archives: Mail archives, ZIP, TAR

Extract **Keep compression**
By extracting the files, you get more accurate file-size estimates but larger files.

Spreadsheets: Excel

Images: JPG, GIF, PNG

Collaboration: Sharepoint, Newsgator, Jive

Programming: Java, C, C++, Python, CSS

Search terms [Hide Tips](#)

Age or harassment

[Cancel Request](#)

StoredIQ for Legal eDiscovery for IT:

- Receive and manage preservation and collection requests directly from legal in the same solution
- Manage data request creation and fulfilment process with the right level of detail for legal and IT teams with a common understanding of request criteria, status, next steps, and outcome across all data sources
- Utilize multi-data source, date range, custodian criteria via fully customizable intake forms and fulfilment workflows
- Track status and provide communication through the process
- Capture results of the identification, preservation and collection activities

Generate precise insight to speed eDiscovery

Approximately 90 percent of corporate cases are settled prior to the collection process. In many organizations where no insight into data associated with a case is available, a settlement is made with little to no information regarding the actual merits of the case. StoredIQ for Legal is designed to accelerate the eDiscovery process and provide legal teams with insight into relevant data in-place prior to collection. This capability helps litigators make more informed decisions about whether to settle or litigate. If litigation moves forward, StoredIQ for Legal determines which data needs to be collected, and then collects the smallest legally defensible set of data.

Connect your data

From identification through collection, preservation and production of vendor-agnostic, review-ready load files, StoredIQ for Legal supports legal teams with deep data analysis. The solution identifies, collects and preserves active electronically stored information (ESI) on over 75 common enterprise data sources and more than 450 file types, including network servers, storage systems, laptops and cloud-based data—all while avoiding disruptions to end users.

Filter your data to create a custom data set

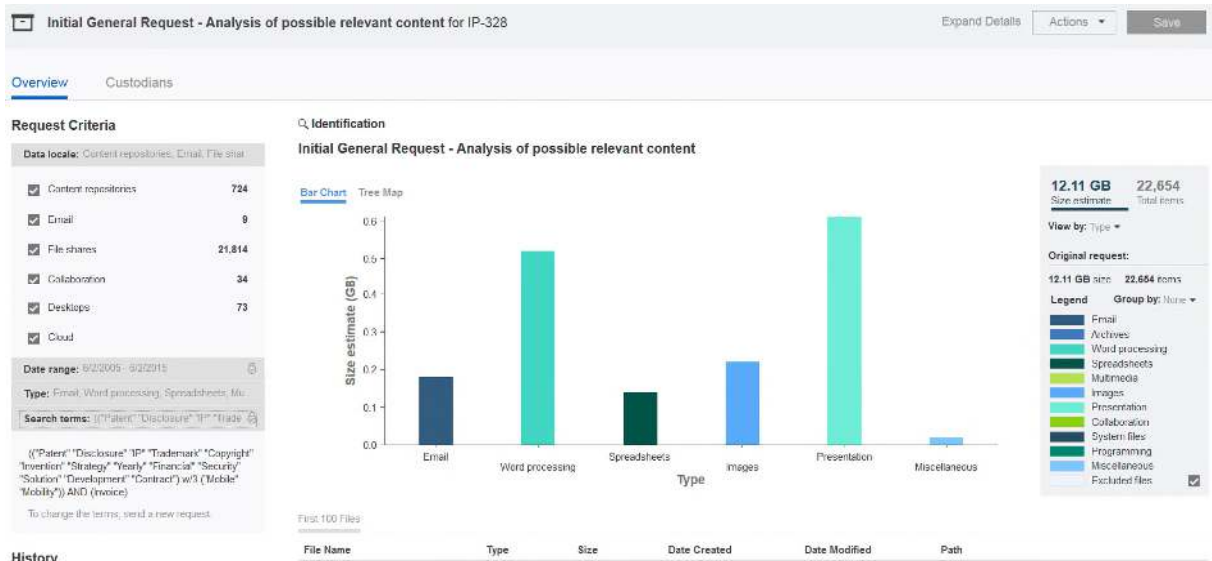

StoredIQ for Legal helps accelerate the understanding of large amounts of unstructured content through powerful search functionality, filters and explorers. Data can be filtered or acted upon and can be refined using a visual heat map. Data explorers visually represent unstructured data from various points of view, such as file system metadata attributes, data source location and category.

Defensibly present your eDiscovery workflow

With StoredIQ for Legal, legal users can take action to copy data to a retention server, move data for archiving, export data for review or delete data—with defensible actions and a full audit trail. Data topology, overlay hit, term hit, duplicate and data assessment reports provide valuable insight designed to help legal teams make more informed decisions about the merits of a case, prior to collection.

Implement comprehensive Information Lifecycle Governance



To maximize operational efficiency, control costs and reduce risks, organizations should integrate the eDiscovery process into a comprehensive approach to Information Lifecycle Governance (ILG). StoredIQ for Legal is part of IBM's Information Lifecycle Governance suite, which offers solutions for not only legal eDiscovery, but also records management and retention, archiving, curation, and content assessment and cleanup. Teams can automate records retention and disposal; efficiently archive content while enforcing policies; identify and process the most important data; remediate old, redundant data; and more. With IBM, organizations gain a powerful, comprehensive suite of ILG solutions from a single vendor.

IBM provides an integrated, modular and scalable information governance platform that enables line-of business and IT professionals to more effectively understand and act on data where it resides. Leveraging the fabric of our information governance foundation to optimize existing legal, records, compliance and IT processes, IBM enables customers to manage enterprise information according to its business value, comply more efficiently with litigation and regulatory mandates and defensibly dispose of information that no longer has value or preservation requirements.

Owned/Supplied by :	IBM
Used by :	IBM

8.2.60 TransCEND (a TransPerfect Legal Solutions Company)

Summary

TransPerfect is the world's leading provider of language services and technology solutions. Our proprietary legal exchange platform, TransCEND, enables firms to share files in a completely secure environment. Offering the industry's fastest repository creation, 24/7/365 support, and multijurisdictional hosting capabilities, TransPerfect is a trusted partner for every Am Law 200 and Global 100 law firm, as well as the majority of Fortune 1000 corporate legal departments.

Some of the enhanced features that we provide:

- Increased Security – Most secure platform on the market with SSAE 16 SOC 2 hosting, advanced intrusion detection, multi-factor authentication and IP filtering capabilities
- Document Protection – Industry leading Information Rights Management (IRM) capabilities that can disable screenshots, copy & paste, snipping, printing and downloading
- Business Rules Engine – Ability to create custom business logic that can be triggered based on metadata coded for documents, providing contract management capabilities
- Automated Version Control – Ability to check-in/out documents and utilize Open-In-Office protocols to edit and version Microsoft Office files directly through the application
- Custom Metadata Fields – Fully keyword searchable dropdown menus, radio buttons, check boxes, calendaring options and text fields associated with individual documents
- Multilingual User Interface – Stakeholders from different regions can review the user interface in their own languages which increases usability for non-native English speakers
- Simplified Invite Process – Bulk invitations can be sent from the system to all the authorized parties simply by copying & pasting recipients' email addresses into our system
- Built-in Redaction – Ability to black out, highlight or annotate text using our built-in redaction system and grant users access to native documents or the redacted versions
- Usage Activity Reports – Includes advanced features such as data filters and report previews. Export reports to the program of your choosing (CSV, XLS, DOC, PDF)
- Email Documents – Documents can be emailed directly to the application index as attachments where they can be dragged and dropped into the appropriate folders
- Communicate – Communicate important information to individuals, groups, or organizations through the secure email system and Q&A module directly from the workspace
- Advanced Search – Ability to conduct Boolean & Lucene searches using custom operators and save both private & public search results to come back to them in the future

Security is Key:

- SSAE 16 SOC 2 Certified Hosting
- HTTPS Connection Running SSL Encryption
- Annual Audits and Penetration Tests
- Two Factor Authentication Process
- Multilingual User Interface and Support
- Document Encryption (Information Rights Management)
- Concurrent Login Restrictions
- Dynamically Watermarked Pages
- Inactivity Logout Timer
- Fast and Secure Scanning of All Documentation

Owned/Supplied by :	TransPerfect Legal Solutions
Used by :	TransPerfect Legal Solutions

8.2.61 TSD Relativity Product Suite



Billing is an essential, recurring component of any project, and making the process more efficient can yield long-term savings. It consumes a lot of time and energy which could be used for much more productive activities. Of course, it is a crucial part of business, so it definitely deserves a sufficient amount of attention and preciseness.

But why does billing have to be difficult and time-consuming? There is now an innovative billing system within Relativity® and RelativityOne platforms. Users of MaxBilling are able to automate the billing process by setting up billing periods and rates for various metrics (CaseRollup, Case Flow, Users, Analytics, Processing, Tasks) and generating accurate and detailed reports with calculated costs, minimizing time, effort, and the potential for making errors

MaxBilling main features and functionality:

- Supports RelativityOne and Relativity 9.3 and above
- Automatic report & invoice generation with custom schedule options
- Available reports in PDF, summarized Excel, detailed Excel and ExportData files
- Reports for Instance, Workspace, Matter and Client level
- Single- and multi-client reports
- Custom and recurring billing periods for your periodic incremental usage check-ins
- Various pricing metrics and custom rates out of the box: Case Rollup, Case Flow, Users, Analytics, Processing, Indexes, Custom Tasks
- Collection of peak values for file and index usage including native files, dtSearch indexes and analytics indexes
- Charge clients for single, multiple, or all workspaces at once
- Multiple invoices for one report with just one click
- Customizable invoices based on mappings and templates
- Billing profile inconsistency notifications
- Dashboards
- Logo for billing reports and invoices
- Customizable pricing items

Chapter 8 – Supplier & Software Details



Client Name	Relativity Instance		
Currency	USD \$		
Report Period Start Date	11/1/2018 12:00:00 AM		
Report Period End Date	1/31/2019 12:00:00 AM		
Report Generated On	1/21/2019 6:11:04 PM		
Subtotal	781,552,101.82		
Total Discount	(1,576,849.87)		
Grand Total	779,975,251.95		
Workspaces	1014823 - New Case Template; 1018815 - AMALAR Workspace; 1019114 - Workspace 7; 1019197 - RIP Test Workspace 2018 - ^123% - #; 1019198 - Workspace 3; 1033121 - MaxBilling; 1020406 - ECA Test		

Relativity Instance Subtotal: 781,552,101.82 Discount: (1,576,849.87)	Client Total: 779,975,251.95
---	---

Billing Item	Billing Code	Unit	Usage	Unit Price	Subtotal	Discount	Total
Image File Count ¹	X308	In Whole	1547.00	100.00	200.00	20.00	180.00
Production File Count ²	X308	Count	993.00	4.00	3,972.00	0.00	3,972.00
Native File Count ³	X308	In Whole	9887.00	200.00	1,000.00	0.00	1,000.00
Total File Size ⁴	X308	KB	1200283.66	1.00	1,200,283.66	0.00	1,200,283.66
LDF Size ⁵	X308	MB	9731.00	13.00	126,503.00	0.00	126,503.00
Image File Size ⁶	X308	MB	762.00	9.00	6,858.00	0.00	6,858.00
Production File Size ⁷	X308	MB	37.47	6.00	224.82	0.00	224.82
Native File Size ⁸	X308	KB	2207587.59	3.00	6,622,762.77	662,276.27	5,960,486.50
Extracted Text Size ⁹	X308	KB	117068688.00	2.00	234,137,376.00	0.00	234,137,376.00
Used DB Size ¹⁰	X308	KB	25827133.00	5.00	129,135,665.00	0.00	129,135,665.00
Available DB Size ¹¹	X308	MB	8576.01	13.00	111,488.13	0.00	111,488.13
Document Count Text Only ¹²	X308	In Whole	1515151.00	150.00	150.00	0.00	150.00
Document Size Text Only ¹³	X308	GB	378.79	222.00	84,091.38	0.00	84,091.38
Full Text Data File Size ¹⁴	X308	MB	118.93	16.00	1,902.88	0.00	1,902.88
Publish Data File Size ¹⁵	X308	KB	398388164.90	1.00	398,388,164.90	0.00	398,388,164.90
Total File Count ¹⁶	X308	In Whole	0.00	300.00	0.00	0.00	0.00
Document Count Text Only ¹²	X308	Count	9907.00	5.00	49,535.00	0.00	49,535.00
MDF Size ¹⁷	X308	KB	534720.00	1.00	534,720.00	53,472.00	481,248.00
Total File Count ¹⁶	X308	In Whole	12442.00	55.00	275.00	27.50	247.50
MDF Size ¹⁷	X308	MB	6747.82	14.00	94,469.48	0.00	94,469.48
Total File Count ¹⁶	X308	Count	1118.00	3.00	3,354.00	335.40	3,018.60
Document Count Text Only ¹²	X308	In Whole	67.00	300.00	300.00	30.00	270.00

#	Artifact ID	Name	Type	Billing Profile	Client	Period Start Date	Period End Date	Generated Date
1	1114720	All Clients (20190201-20190202)	Multiple Clients	All Clients	All Clients on Profile	02/01/2019 12:00 AM	02/02/2019 12:00 AM	02/01/2019 6:08 PM
2	1114632	All Clients (20190201-20190202)	Multiple Clients	All Clients	All Clients on Profile	02/01/2019 12:00 AM	02/02/2019 12:00 AM	02/01/2019 5:53 PM
3	1114545	All Clients (20190201-20190202)	Multiple Clients	All Clients	All Clients on Profile	02/01/2019 12:00 AM	02/02/2019 12:00 AM	02/01/2019 5:07 PM
4	1114450	Combined workspaces (20181...	Multiple Clients	Combined workspaces	All Clients on Profile	11/01/2018 12:00 AM	01/31/2019 12:00 AM	01/31/2019 5:37 PM
5	1114444	Combined workspaces (20181...	Multiple Clients	Combined workspaces	All Clients on Profile	12/01/2018 12:00 AM	01/31/2019 12:00 AM	01/31/2019 5:35 PM
6	1114438	Combined workspaces (20181...	Multiple Clients	Combined workspaces	All Clients on Profile	12/01/2018 12:00 AM	01/31/2019 12:00 AM	01/31/2019 5:11 PM
7	1114303	Processing (20181201-201901...	Multiple Clients	Processing	All Clients on Profile	12/01/2018 12:00 AM	01/31/2019 12:00 AM	01/30/2019 12:19 PM
8	1114250	All Clients (20181230-20190130)	Single Client	All Clients	Client 3	12/30/2018 12:00 AM	01/30/2019 12:00 AM	01/30/2019 12:03 PM
9	1114248	All Clients (20181230-20190130)	Single Client	All Clients	Client 2	12/30/2018 12:00 AM	01/30/2019 12:00 AM	01/30/2019 12:03 PM
10	1114154	All Clients (20181230-20190130)	Single Client	All Clients	Client 1	12/30/2018 12:00 AM	01/30/2019 12:00 AM	01/30/2019 11:58 AM
11	1114147	All Clients (20181230-20190130)	Single Client	All Clients	Dev Client	12/30/2018 12:00 AM	01/30/2019 12:00 AM	01/30/2019 11:57 AM
12	1114133	All Clients (20181230-20190130)	Single Client	All Clients	Relativity	12/30/2018 12:00 AM	01/30/2019 12:00 AM	01/30/2019 11:56 AM
13	1114106	All Clients (20181230-20190130)	Single Client	All Clients	Relativity Template	12/30/2018 12:00 AM	01/30/2019 12:00 AM	01/30/2019 11:55 AM
14	1114075	Processing (20190101-201901...	Multiple Clients	Processing	All Clients on Profile	01/01/2019 12:00 AM	01/31/2019 12:00 AM	01/30/2019 11:53 AM
15	1113374	Instance Profile (20181101-20...	Instance	Instance Profile	Relativity Instance	11/01/2018 12:00 AM	01/31/2019 12:00 AM	01/21/2019 6:11 PM
16	1113344	All Clients (20181201-20190119)	Single Client	All Clients	Client 3	12/01/2018 12:00 AM	01/19/2019 12:00 AM	01/21/2019 10:13 AM

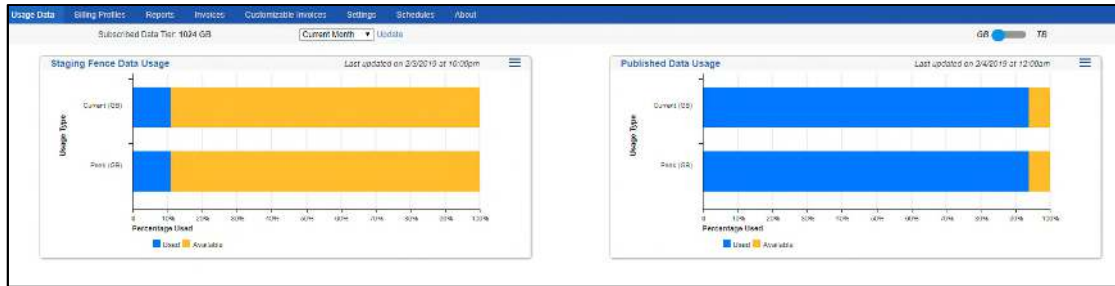

If you're a project or case manager, you know how complex discovery projects can be. Case strategy and more can change at a moment's notice – and these changes need to be communicated at the right time, to the right people.

MaxMessage streamlines communication across Relativity®, making it easier than ever to get information to your teams. Compose rich-text messages, add attachments and schedule communications to be sent instantly or during specific time periods to different targets – individual users, a group of users, all users in a workspace, or all users in a Relativity® instance. Track message acknowledgement and never ask yourself, “Did they get my email?” again.

MaxMessage main features and functionality:

- Compatibility with Relativity® 9.3 and above
- Scheduling and sending rich-text messages to different targets
- Attaching various files to messages
- Ability to track message attachment downloads
- Receiving instant notifications/reminder popups anywhere in Relativity®
- Access to Acknowledgment Message History
- Access to Inbound Message History
- Ability to download Acknowledgment Status Report in PDF file

Chapter 8 – Supplier & Software Details

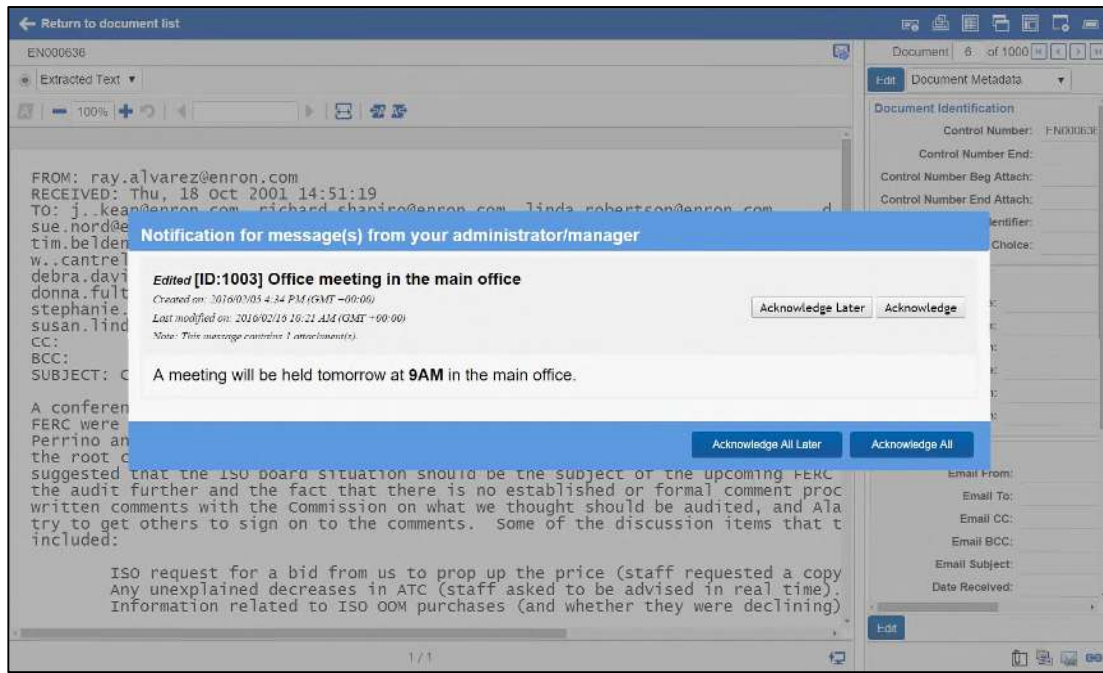

#	User ID	User Name	Status	Notification Seen On	Acknowledged On	Attachment Download Status
1	9	Relativity Admin (relativity.admin@kcura.com)	Acknowledged	2016/02/16 10:21 AM (GMT +00:00)	2016/02/16 10:21 AM (GMT +00:00)	1/1 1. important NOTES.txt downloaded on 2016/02/16 1:24 PM (GMT +00:00)
2	777	Relativity Service Account (relativity.serviceaccount@kcura.com)	Not Seen			0/1 1. important NOTES.txt not downloaded yet
3	1021777	Jane Dao (jane@dao.com)	Acknowledged	2016/02/16 10:23 AM (GMT +00:00)	2016/02/16 10:23 AM (GMT +00:00)	0/1 1. important NOTES.txt not downloaded yet
4	1021781	Young Old (young@old.com)	Seen	2016/02/16 10:28 AM (GMT +00:00)		1/1 1. important NOTES.txt downloaded on 2016/02/16 10:28 AM (GMT +00:00)
5	1021782	March April (march@april.com)	Acknowledged	2016/02/16 10:21 AM (GMT +00:00)	2016/02/16 10:21 AM (GMT +00:00)	0/1 1. important NOTES.txt not downloaded yet
6	1021785	Salt Pepper (salt@papper.com)	Not Seen			0/1 1. important NOTES.txt not downloaded yet
7	1021790	Sweet Candy (sweet@candy.com)	Seen	2016/02/16 10:24 AM (GMT +00:00)		1/1 1. important NOTES.txt downloaded on 2016/02/16 10:26 AM (GMT +00:00)

Owned/Supplied by :	TSD Services Ltd
Used by :	TSD Services Ltd

8.2.62 UFED Series

The UFED Series consists of Hardware and Software products providing professionals a set of effective tools to extract, decode, analyse and report of data from mobile devices. It covers the full range of data collection for investigative and eDiscovery purposes and is used by law enforcement and litigation support professionals worldwide.

Cellebrite's UFED Touch and UFED4PC Ultimate enable the most technologically advanced **extraction, decoding, analysis and reporting** of mobile data. It performs **physical, logical, file system and password extraction** of all data (even if deleted) from the widest range of devices including legacy and feature phones, smartphones, portable GPS devices, tablets and phones manufactured with Chinese chipsets.

With proprietary hardware, an integrated battery, an intuitive GUI and touch screen, the UFED Touch Ultimate speeds up the investigation process, meeting the demands of the mobile forensic industry.

UFED 4PC Ultimate is a versatile offering, that runs on existing hardware alongside other third-party software. It comes with a range of applications, invaluable for investigators to close cases faster:

- [UFED Physical Analyzer](#) – The advanced application for decoding, analysis and reporting
- [UFED Phone Detective](#) – For instant mobile phone identification
- [UFED Reader](#) – Enables authorized personnel to share information with others

Highlights:

- Physical extraction from BlackBerry devices running OS 4-7. Exclusive decoding: BBM data, apps, emails, Bluetooth etc.
- Widest support for Apple devices running iOS3+.
- Physical extraction and decoding while bypassing pattern lock / password / PIN from Android devices including HTC, Motorola, Samsung Galaxy SIII family and more.
- Physical extraction from Nokia BB5 devices – password extraction from selected devices.
- File system extraction from any device running Windows phone 7.5 and 8 including Nokia, HTC, Samsung, Huawei and ZTE.
- The most powerful solution for phones with Chinese chipsets.
- TomTom trip-log decryption, and data extraction from other portable GPS devices.
- Obtain existing and deleted data: apps, passwords, emails, call history, SMS, contacts, calendar, media files, geotags, location information, GPS fixes etc.
- Proprietary technology and boot loaders ensure forensically sound extractions.
- Frequent updates to ensure compatibility with new phones as they enter the market.

Cellebrite's UFED Link Analysis is a new application which immediately identifies and visualizes the connections and communication methods used between multiple mobile devices, based on data extraction reports.

UFED Link Analysis provides fast results for first responders and creates a bigger picture of any investigation:

- Reveal communication links between multiple mobile devices based on a rich data set: mutual contacts, calls, SMS, MMS, email messages, chats, application transactions, Bluetooth devices, locations and more.
- Understand how entities are connected by visualizing data from multiple devices.
- Visualize the communication directions between entities, pinpointing bidirectional and unidirectional communication.
- Discover if entities were at the same place at the same time.
- Drill down to specific events.
- Share your findings with other investigators.

Main Features:

- **Entities analytics:** Statistical data shows the frequency of communication and preferred communication methods.
- **Timeline:** Displaying a list of events in chronological order.
- **Location analytics:** Analyse multiple suspects locations on a single map.
- **Mutual and all links graphs:** View the suspects and the entities.
- **Advanced filters:** Filter data based on date and time, communication methods, location types and distance.
- **Investigation data enrichment:** Add data or pictures on entities in extractions.
- **Advanced search:** Search for information based on free text or several parameters.
- **Project and table search:** Text search on all data available in the project or table.
- **Report generation:** Customize reports containing detailed information and graphs.
- **Graph snapshot:** Save an image of the current view.
- **Project management:** Save the project information.
- **Suspect's data management:** Add data and pictures collected during the investigation.

Owned/Supplied by :	Cellebrite
Used by :	Cellebrite, FRA

8.2.63 Venio

VenioOne

Better Discovery. Better Decisions

The landscape of disclosure is continuously evolving. From new rules and practice directions to the addition of new data sources and the rising concern over security and privacy (corporate and personal), today's legal teams require more than just analytics and review tools. The precipice of data disclosure has expanded the boundaries of discovery to include also investigations (internal and external), data management in situ, compliance and regulatory reviews, not to mention the expansion of remote office and locations to name a few. And while discovery requirements around the globe change, the necessity to understand budgets and data insights quickly has not.

Venio Systems has taken a new direction with our discovery software solution. More than a solution, we provide a fully unified platform that our clients use to ingest and process data, perform early case analysis (ECA), analyse and review using customisable and automated workflows, machine and active learning technology, and export files. In response to the modern landscape of discovery, law firms and legal teams need a discovery and investigation solution that is more agile and adaptable than ever. Venio Systems has responded to our client's needs and challenges by introducing more automation into our software, advanced AI technologies, and flexible interfaces that are equally responsive for small data matters as for big complex data matters too. A single unified software solution means centralized data management across the discovery/investigation workflow. It also means more efficient workflows, better security and easier integration with other legal software too.

Processing/Administration & Applets

VenioOne's processing supports more than 500 different files types, forensic images and foreign language documents. The intuitive console is a single interface for managing processing rules for new matters and existing matters, the administration of security and user permissions, and the Applet component for customized workflows and integrations. A scalable and multi-tenet platform, VenioOne's distributed processing is fast and easily manages multiple projects across multiple clients at the same time. The automated and customisable processing workflows enhance performance and reduces pre-processing and post-processing data management time.

A completely unified platform, data is immediately ready for analysis and review as soon as it has been processed. While VenioOne includes review as part of our more efficient discovery workflow, we do support all major industry review software and can export industry standard load files directly from processing solution.

Chapter 8 – Supplier & Software Details

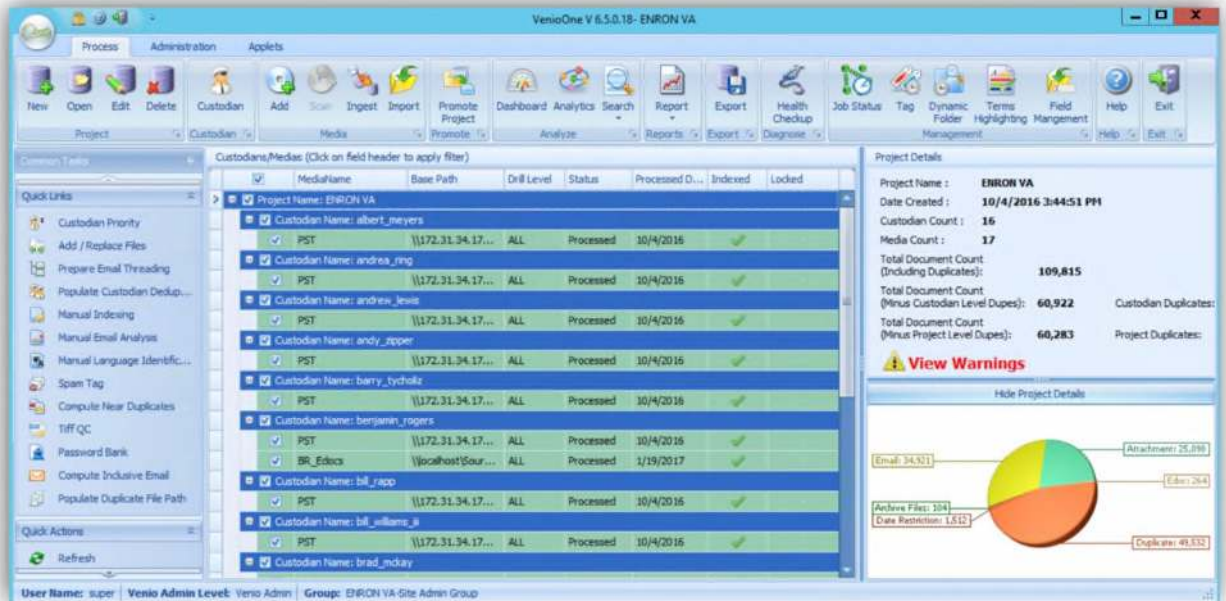

VenioOne Processing, Administration & Applet Console

Visual ECA & Project Dashboard

The VenioOne Project Dashboard is a powerful visual overview of data information such as media, custodians, and documents for the selected project. Users can take action directly within the Dashboard with additional search and tag functionality. Case managers, investigators and users can assess data volumes by characteristics such as file type, domain, or language. Groups of documents can be tagged for culling, review, further investigation and/or to generate searches.

Users can perform ECA, investigations, and a number of early culling tasks directly from the Project Dashboard without waiting for a review process to begin.



VenioOne Project Dashboard

Machine & Active Learning Analytics

Venio Assisted Review (VAR) leverages predictive coding technologies to aid reviewers in the prioritization and coding of documents during review. An unlimited number of categories can be created and used to train VAR for document recognition. As with other Assisted Review technologies, VAR is used by subject matter experts or review teams to predict documents’ relevance based on a known set of data. The unified architecture of VenioOne platform enables the use of VAR immediately after data has been processed and the legal team has gathered training documents.

Continuous Active Learning (CAL) technology will be integrated within the Venio Assisted Review module during 2018.

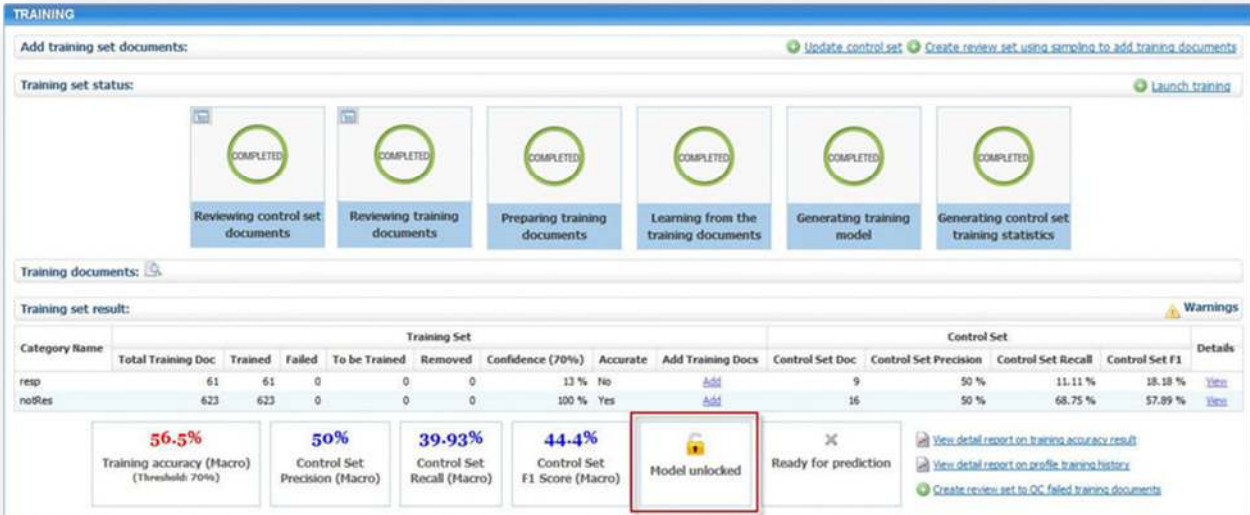

VenioOne Assisted Review - Predictive Coding Interface

Review

The Review Module in VenioOne enables the review of documents that have been batched by tag, folder, saved search, VAR profile, sampled documents, redaction sets or Dynamic Folders. Administrators establish review permissions for different sets of documents to be reviewed by specific groups of users.

The VenioOne Document Review Interface is designed to expedite the linear review process through automation and custom workflows. By default, VenioOne displays the Document Table, Document Viewer and Tags/Coding panel with an ability to add panels to display more information or detach panels for dual-screen workstations.

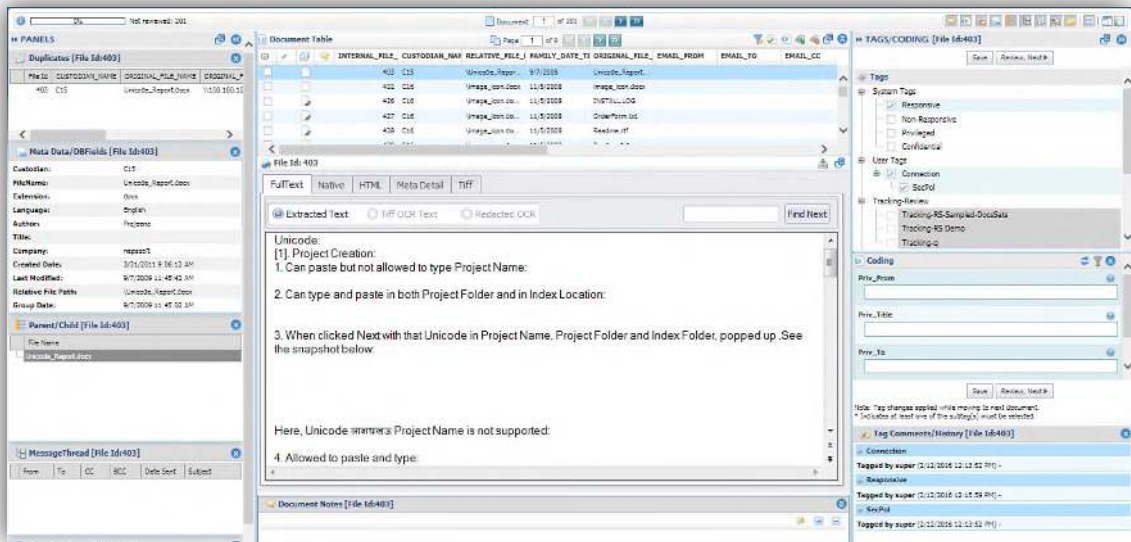

VenioOne Review Interface

VenioOne OnDemand

VenioOne OnDemand (VOD) allows end users to immediately upload, analyse, review and produce electronic documents in a scalable and secure environment. Perfect for service bureaus and law firms, as well as organizations seeking an easy-to-use internal discovery solution, VOD enables automated self-service eDiscovery with centralized administration that can be securely hosted behind the firewall or in the cloud using the VenioOne platform. VOD is simple yet powerful even enabling workspaces for review teams and investigators to collaborate as well as invite others to securely upload data into a project from anywhere via the “invite to upload” feature.

VOD is a web-based extension of the VenioOne platform. It is a unified interface to VenioOne that provides drag and drop data uploads, a full featured review tool, advanced search, data analytics, and an intuitive interface while relying on VenioOne as a centralized administration hub.

By leveraging this unique architecture, VOD provides organizations with the flexibility to scale their legal technology seamlessly across multiple internal and client locations, without the labour or cost required to buy, install, and maintain additional infrastructure. All managed from one central location.

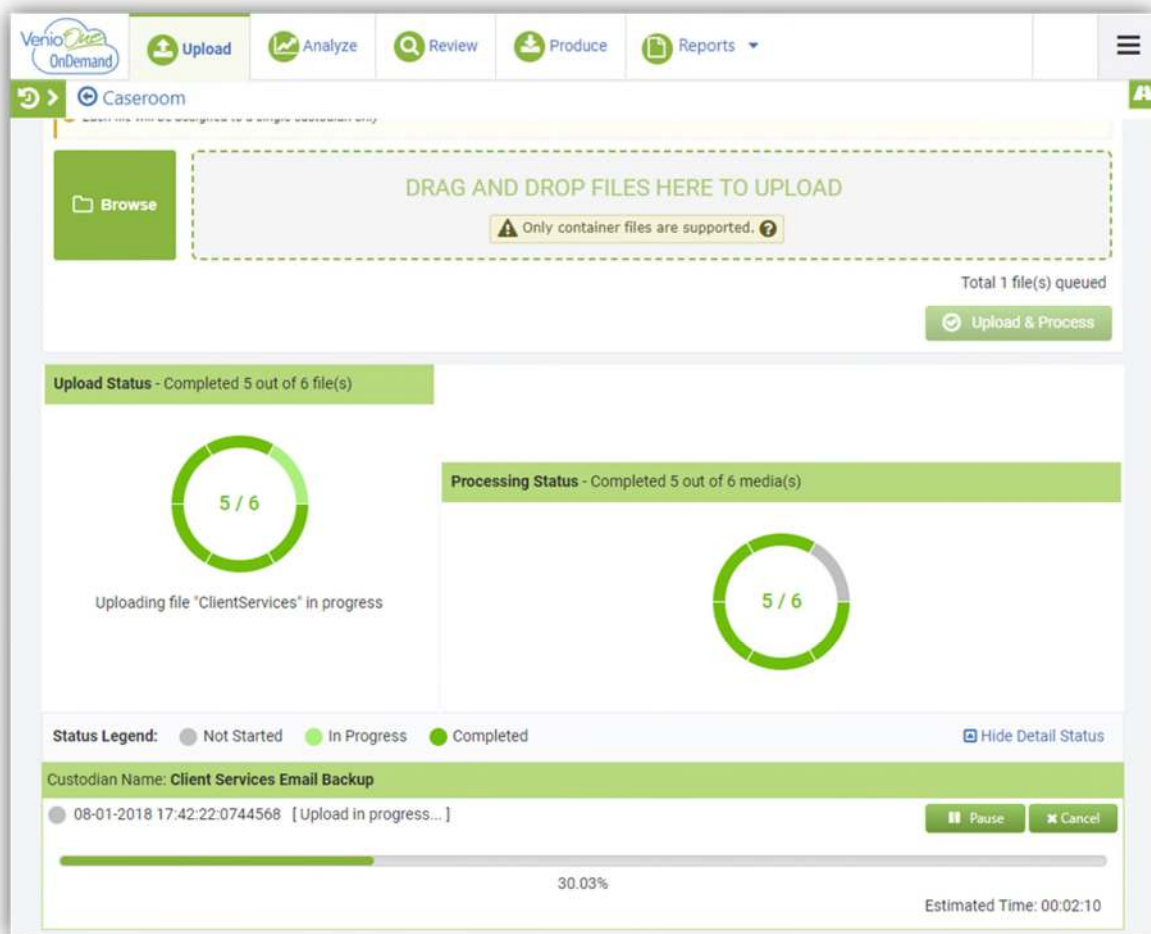

VenioOne OnDemand Upload Interface displaying Upload and Processing Status

Chapter 8 – Supplier & Software Details

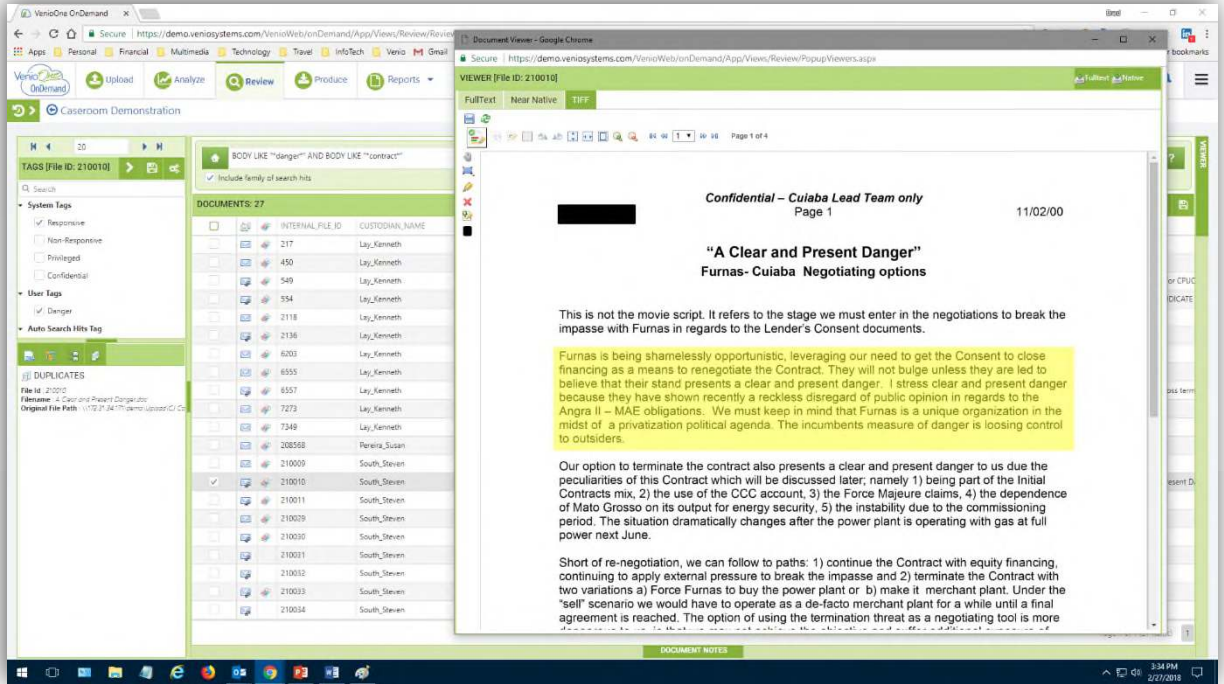

VenioOne OnDemand Review Interface with detached Image Viewer in Redaction Mode

Owned/Supplied by :	Venio
Used by :	Inventus

8.2.64 Veritas

End to end Intelligent Electronic Discovery Software *Version 9.1* ([released Oct 2018](#))

Respond to regulatory requests - Improve accuracy and meet strict deadlines. [Veritas eDiscovery Platform](#) now includes complete integration with the Veritas [Classification Engine](#) by delivering powerful intelligence into data risks on-premises and in the cloud. Through this new integration, customers can quickly scan and tag data, using a pre-designed set of classifications. This helps to ensure that sensitive or risky information is properly managed and protected. Be ready for impending privacy regulations such as GDPR or strict subject access requirements in FOIA.

- Classify, redact and annotate sensitive and personal data to defensibly satisfy Subject Access Requests
- Classification - Accelerate review of personal data by classifying data using Integrated Classification Engine (ICE) with configurable classification rules
- Pre-set Redaction Codes - Ensure consistent reasons for redacting data by pre-defining list of redaction codes for your reviewers and then search & filter by those reason codes
- Bulk Redactions - Mask sensitive data quickly and reducing review time & costs by redacting text across an entire dataset
- Annotation – Emphasize certain parts of a document by highlighting, commenting, stamping and using arrows
- Use intelligent Auto-Filters and Transparent Search to expedite your growing compliance workload
- Comprehensive case dashboard ensures compliance officers have a single-pane-of-glass view into ongoing investigations

The [Veritas eDiscovery Platform](#) brings transparency and control to the electronic discovery process. From legal hold to production, our workflow speeds time to resolution, improves accuracy and lowers costs. With better insight and less complexity, the eDiscovery Platform enables you to focus on strategy and create business value. It allows enterprises, governments, litigation support partners and law firms to manage legal, regulatory and investigative matters using a single application. Making it easy for organizations to cost effectively and defensibly solve real-world challenges across the entire eDiscovery lifecycle.

Key Features

Transparent Predictive Coding

Open up the black box of technology-assisted review with Transparent Predictive Coding. This feature leverages machine learning technology to improve the efficiency and effectiveness of traditional linear review with increased accuracy, workflow defensibility, and tagging transparency. Predictive Coding Defensibility and the Transparent Predictive Coding Workflow

Audio Processing, Search, & Review

Multimedia content is growing rapidly within organizations and recent regulatory activity, including the Dodd-Frank Act, has brought these file types into the electronic discovery spotlight. Veritas offers a powerful phonetic-based solution for rapidly processing audio content and making it immediately available for search and review.

Enterprise Vault Collector

Manage data through the entire EDRM workflow with a single application by collecting content directly from Enterprise Vault. Using Enterprise Vault Collector, you can apply legal holds to content in the archive from the eDiscovery Platform.

Distributed Architecture

Quickly and easily add capacity on demand with the distributed architecture of the eDiscovery Platform. For the largest and most complex cases, this flexibility improves processing speed, user scalability, and export efficiency.

Key Benefits

Bring transparency and control to the entire electronic discovery process from legal hold and collection through production with a single platform and reduce costs.

Reduce the time of legal document review and cut costs by up to 98% with Transparent Predictive Coding.

Speed time to resolution and lower costs by reducing information for review by 90%.

Improve productivity of legal and IT staff immediately with an intuitive interface that is easy to use with minimal training.

Deploy the eDiscovery Platform as a single unified application or tailor the solution with just the modules you need.

Empower users to be productive immediately through an intuitive, Web-based platform that is easy to use and administer.

Archiving & eDiscovery

Improve Information Governance, Reduce Risk and Save Money

With Veritas Enterprise Vault™ and the eDiscovery Platform, Veritas delivers the first fully integrated electronic discovery and archiving solution. Legal and investigative teams now have a single, seamless interface to search and collect data, place holds within the archive, and perform analysis and review. With integrated classification to Enforce intelligent retention policies by quickly locating and quantifying valuable and sensitive data.

More Information

For data sheets, product updates and more detail on the features and benefits, visit; <https://www.veritas.com/product/information-governance/ediscovery-platform>

Figure 5. Automated tracking and reporting: View the status of all legal hold notices across all cases in a single view.



Chapter 8 – Supplier & Software Details

Figure 6. Collection analytics: Provide a complete portfolio of analytical charts and tables that offer real-time visibility into the status of the collection

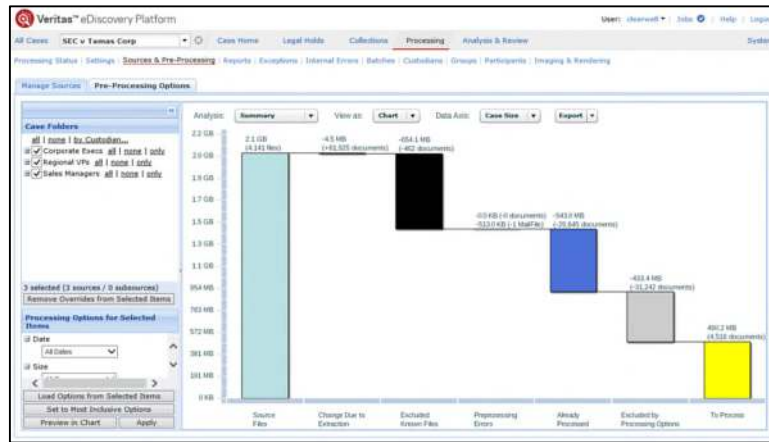

Figure 7. Pre-processing analytics: Graphically depict data volume, file types and time frames of collected data prior to processing

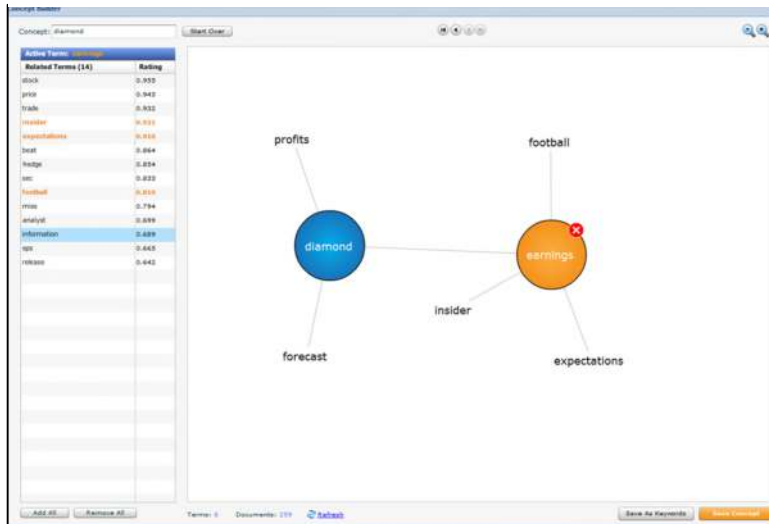

Figure 8. Concept search explorer: Provides a visual interface to dynamically explore and discover new relevant concepts



Chapter 8 – Supplier & Software Details

Figure 9. Lifecycle reporting: Summarizes case status from collection through production in a single dashboard

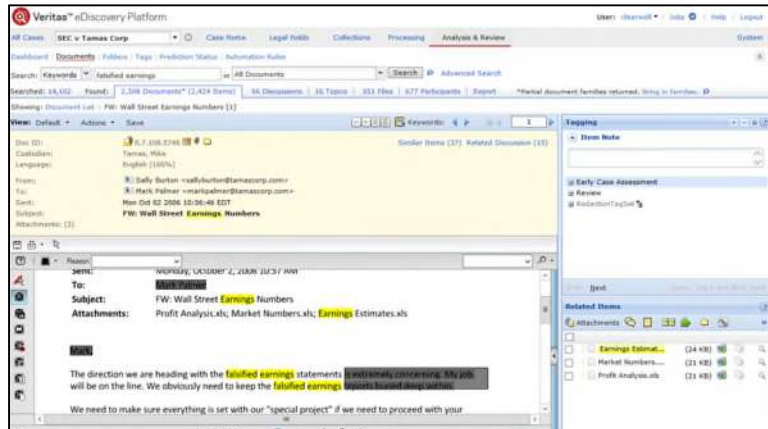

Figure 10. Near-native viewer: Access documents, attachments and email threads in near-native formats for review, tagging and redaction

Owned/Supplied by :	Veritas
Used by :	CMS Derks Star Busmann, CYFOR, Deloitte, BSI, Epiq, Grant Thornton, KPMG, LINEAL, Navigant

8.2.65 Viewpoint

VIEWPOINT FEATURES:

Identification: Viewpoint maintains the capability to access any machine connected to the network to identify, mark and copy files contained on file servers and other sources by file type, custodian, date of last access, date creation, system or key terms.

Collection and Preservation: The Viewpoint Collection and Preservation module allows users who have implemented Viewpoint within their own network infrastructure to perform active file collection and preservation. Through a simple point-and-click interface, corporations may filter by a number of parameters to collect and preserve electronically stored information, forensically copied and preserved directly into the Viewpoint's Evidence Repository.

Evidence Repository: Viewpoint's Evidence Repository preserves all data collected for every project throughout the lifecycle of the matter. All data is forensically maintained prior to filtering, culling or deduplication to provide an easily acceptable data warehouse that allows the legal team to repeatedly access evidence as refinement of the parameters in the case unfold. The ability for the legal team to easily "go back to the well" to further sample additional terms, concepts and other criteria is fully integrated with a robust reporting engine to display results of various "what if" scenarios.

Pre-Processing: The Viewpoint Pre-Processing solution enables clients to greatly reduce electronic data sizes at the earliest stages in the e-Discovery lifecycle. For a fraction of full processing costs, Viewpoint pre-processing will de-nist, de-dupe and even apply dynamic date filters to quickly cull large sets of data. By removing system files and unwanted documents before processing begins, Viewpoint will save you both time and money throughout the e-Discovery process

Viewpoint's unique pre-processing features include:

- Data cataloguing
- File extension filtering
- Fully recursive document level date/time filtering
- File type identification
- User-directed file folder removal
- MD5 Hash calculation NIST filtering, system file removal
- De-duplication

Processing: Viewpoint's lightning fast processing solution offers advanced capabilities to provide channel partners, corporations and law firms the ability to filter and process large volumes of data in a fraction of the time it would normally take. With our scalable technology, clients can begin to review and analyse data sooner, as well as perform analytics and data assessments early on in the case to assist in 26(f) planning and analysis before data is posted for review. Viewpoint Processing is the perfect solution for cutting back on burdensome review costs.

Early Filtering: Viewpoint's advanced early filtering capabilities allow users to apply one or any combination of available filters such as custodian, file type, date range, file size and many more. Early filtering greatly reduces unnecessary and costly processing and review. With a few quick and easy mouse clicks, users can apply custom filters to view only the results they're interested in.

Systematic Deduplication: Clients can avoid wasteful analysis and review time by de-duping within or across all custodians and sources. Viewpoint's intelligent de-dupe algorithm gives the administrator or user choices as the data moves through the

system into review. Additionally, one can always be assured that every document is tracked, saved and available for export by custodian for a completely defensible process.

Multi-language support: Full Unicode and double byte character support is included within the processing platform and currently supports 26 languages. All multi-language documents are fully supported for review, coding, indexing, searching, metadata filtering and production.

Viewpoint also includes:

- Data staging
- Recursive email and e-file container extraction
- Recursive embedded object extraction
- Metadata extraction
- Text extraction
- HTML creation
- Near duplicate identification
- Indexing all data using dtSearch™ engine
- Strata Map (Heat Mapping)
- Visual Index & key term analysis
- File type (extension) analysis
- Email thread redundancy identification
- File validation confirming identity of file type
- TIFF generation
- OCR processing

Viewpoint Assisted Review: Viewpoint's technology-assisted review module is an integrated module within Viewpoint at no additional cost – cuts cost and time by automating review for document prioritization, QC enhancement or wholesale binary review. Viewpoint Assisted Review allows users to:

- Leverage it alongside Viewpoint's analytical tools to build the most efficient "seed" set and drive the most accurate review results
- Utilize it in combination with traditional culling techniques to further minimize the review population in a defensible manner
- Isolate the most highly relevant documents for ECA purposes in order to understand facts of the case early in the matter

Analytics: Viewpoint analytics are seamlessly integrated into your Viewpoint review workflow at no additional charge.

Near Duplicate Review: Eliminate redundant data to accelerate review speed and productivity. Using Near Dupe Similarity Viewer:

- Automatically group similar documents – email, spreadsheets, text files and other electronic data – for any number of custodians
- Review side-by-side version comparison and code individually or en masse
- Exclude non-relevant data from the review process early on to save time and costs

Email redundancy and thread management: Identify and group messages that are 100% contained in subsequent emails in the same thread with a redundancy algorithm that analyses the content of each message to ensure that previous versions of the same thread are contained within subsequent threads.

- Defensibly reduce data volumes by only reviewing the last email in the email thread
- Have 100% confidence that previous emails in a thread are included within the last email
- Identify where an email thread breaks down, and review the last email of the new thread
- Easily detect subject line changes, the addition or removal of correspondents, or where emails are missing all together
- Identify families across multiple custodians to ensure consistent treatment of each thread
- Code entire families at once, preventing inconsistencies across custodians or messages

Relationship Analysis: Identify the who, what and when of email communications between custodians with simple graphic visuals and maps.

- See spikes in communications between custodians early in a matter – eliminating the review of unnecessary data later on
- Identify communications between known custodians and unknown parties to help you comply with discovery requirements
- Know who sent and received important documents within specific timeframes
- Understand communication patterns of interest among various custodians
- Dynamically group communications sent to various network domains (i.e., outside of the company)

Concept Analyzer: Search and visually cluster documents by concepts for one or more sources based on multiple criteria. Clustered concepts can be reviewed immediately, saved or made available to multiple users to access, review and code.

- Quickly identify important topics and groupings of related documents across and between concepts
- Prioritize review early on in a case and focus on what matters most right from the start
- Automatically cluster, search, group, merge, sort, save and print by concept
- Create a focused sampling of documents across the global data set when used in conjunction with Near Duplicate Identification

Visual Index: Get an in-depth look at your search term results – without running time-consuming searches – using the powerful Visual Index search term refinement and document reduction feature.

- Easily identify and exclude false positives in a data set prior to building review assignments
- Reverse the functionality by selecting only the specific terms required for a search
- Generate a tree containing populated search results corresponding to each search term, with a listing of all wildcard and proximity search results

- Refine your original keyword list to generate more targeted and accurate search results using Spelling Suggestion
- Further refine search results by easily incorporating potentially useful terms gathered from the search index
- Easily modify your original search criteria and rebuild your views based on newly fetched search information generated

Strata Map: The Strata's functionality is used to identify and group documents based on user-specified document attributes. Strata's allows users to create multiple layers (or levels) of grouping to help them pinpoint documents for review/investigation or mass tagging.

Review: Viewpoint Review platform is the ideal linear review application. Containing advanced analytical features, Viewpoint Review allows users to perform simple document coding as well as mass coding among email threads or suggestive coding among near dupe families. By decreasing the amount of time it takes for review, clients can accelerate their litigation process while keeping costs low. Our leading-edge review tools include:

Customizable Layout: Viewpoint contains a series of customizable panels that may be located anywhere on the user's desktop and saved in accordance with the reviewer's own preference. Default settings may be controlled by the administrator and dual monitors are supported. Having a clean and manageable workspace will make the review process easier and more efficient.

View Manager Search Preview: Users can not only examine their search results prior to creating a document batch, but they can also ensure that their search and filter criteria were correctly enabled and exclude any false positive occurrences. Clients can also remove documents or add any relevant document not populated by their search.

Native Viewer: Users can review more than 400 documents types in their native format without having to open corresponding applications. This will cut down on review time, further lowering litigation costs.

Suggestive Coding: Users can significantly reduce their review time with Viewpoint's suggestive coding. One can instantly see similar documents across the entire database already coded by other reviewers. Where documents are not exact duplicates, Viewpoint's suggestive coding helps to eliminate conflicting coding and duplicate review of highly similar documents.

Inline Redaction: Our intelligent redaction tool can be used to trim parts of or entire documents. The "redact out" feature is useful for quickly and efficiently blacking out large areas by only having to select the small non-privileged parts. Users can redact 5,000 page Excel spreadsheets in literally seconds.

Keyword Filtering and Hit Highlighting: Upon populating one's keyword results, our dynamic filtering capabilities can be used to display documents containing one or more hits within the entire view. All search terms are clearly highlighted across any document type to help accelerate review time and keep litigation costs low.

Production: Lateral Data’s Viewpoint Production Platform offers efficient document production features that are seamlessly integrated into our enterprise software suite. Lateral Data’s production capabilities enable users to complete the entire electronic discovery process within our vertically integrated system. Viewpoint enables users to manage both outbound and inbound productions in one centralized location. Our advanced production features include:

Native and TIFF Production: Documents can be produced in native, TIFF or other image based formats. All industry standard delivery formats are supported by our flexible production capabilities. Duplicates may be reloaded into productions or suppressed and flagged. Additionally, many customizable delivery features allow users to accomplish the most complicated requirements.

Categorized production folders: Clients will stay organized and efficient by producing and storing documents in the same folder sets utilized during review.

Rolling Production: With rolling production, users can easily produce data on a rolling basis throughout the entire e-Discovery process. Deliveries and all included metadata may be viewed prior to and after actual production within Viewpoint’s production module, ensuring that users have complete control over their data.

Production Security: Once data is produced, users can instantly lock all review folders and documents to preserve coding integrity and prevent others from making changes to delivered data.

Case Management: Lateral Data’s Viewpoint Case Management includes the integrated View Manager for creating and editing document batches and assignments as well as a sophisticated dashboard for selecting projects and viewing project analytics. With Viewpoint’s case management, one can monitor the progress of each case and can be assured that time constraints are being met. Lateral Data’s case management features include:

Viewpoint View Manager: This is the central searching, filtering and project lifecycle console for project managers and reviewers during all phases of the review process. Project managers can use the View Manager to completely automate the creation or editing of unlimited document batches and assignments simultaneously based on one or more search criteria and/or filters.

User Management: Project managers can use the View Manager to enable, disable or modify user accounts and settings. Specific roles can be set up to allow secure access to only certain folders or features.

Activity Logs: Clients can monitor their reviewer’s activity with our dynamic activity log system. All actions such as login, logout, searching and coding can be monitored. By eyeing a team’s progress, project managers will be aware whether or not their team is achieving maximum efficiency.

Viewpoint Dashboard: Our graphical user interface is useful for simplifying administration and providing statistics for predictive reporting, deadline compliance, resource quantification, end-user productivity, coding statistics and other detailed reporting required to successfully manage a project.

Owned/Supplied by :	Conduent
Used by :	LDM Global, QuisLex, Conduent

8.2.66 XBundle Software

XBundle::Assemble is a bundling solution designed to help legal teams efficiently produce high quality, professional electronic document bundles.

- Documents are dragged straight from the desktop or imported via a CSV load file from a document review platform, into virtual lever arch files, providing an at-a-glance archive of all bundles prepared during the course of a case or matter.
- Cross references and hyperlinks are created on-screen by simply dragging and dropping.
- The resulting trial-ready bundles can be exported to PDF for printing, or exported to XBundle::View.

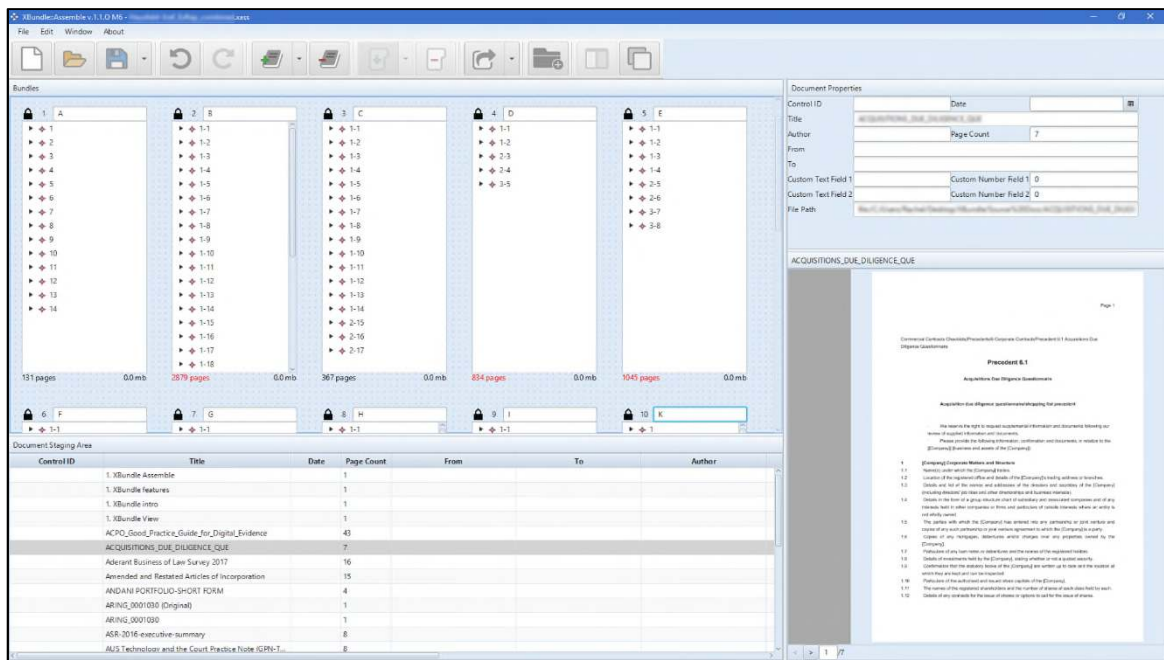

XBundle::Assemble

- XBundle::Assemble supports Excel spreadsheets and provides a full in-application preview showing tabs, formulas and formatting.
- Any file type can be imported into the application and when exported to PDF, non-PDF documents are included as attachments for easy distribution. XBundle::Assemble also has the ability to support audio and video files for export to XBundle::View.
- Fully hyperlinked bundle sets, containing multiple file types, can be quickly produced for distribution as an e-bible format.
- Custom pagination can be applied to the bundles, including pagination per tab, in accordance with the Patents Court.
- Covers, spines and inside labels for print bundles, complete with full case details, are automatically generated and custom indices (which can be exported with hyperlinks to the documents) can be exported on demand.
- After bundles have been finalised, late documents can be added as insert packs with suffixed pagination. These can be exported separately, either to PDF for printing and manual insertion, or to XBundle::View as an update pack.

XBundle::View mimics paper bundles (and can be used seamlessly in parallel with paper bundle sets), but also incorporates hi-tech features such as annotation and collaboration tools, in-built real time transcripts and synchronized media viewing.

The use of widescreen technology to display a split screen view, allows for side-by-side comparison of documents (without the need to scroll or zoom), providing an integrated electronic evidence presentation solution at trials.

- Annotations and highlights can easily be added to documents. When an internet connection is present, users can utilise the system’s collaboration tools, which includes a chat panel where notes and hyperlinks can be shared.
- XBundle::View employs “hybrid cloud” technology, allowing it to bypass the internet and load documents from an encrypted copy of the document store on the user’s USB stick when the internet connection is absent or slow.
- Display monitors can be synchronised so they all show the same page on the command of a designated party member acting as a ‘page turner’.
- Working with the industry’s leading court reporters, XBundle::View can provide real-time unedited transcripts. XBundle::View can link to all mainstream transcription services and provide an edited certified version of the proceedings on a continual updating basis.

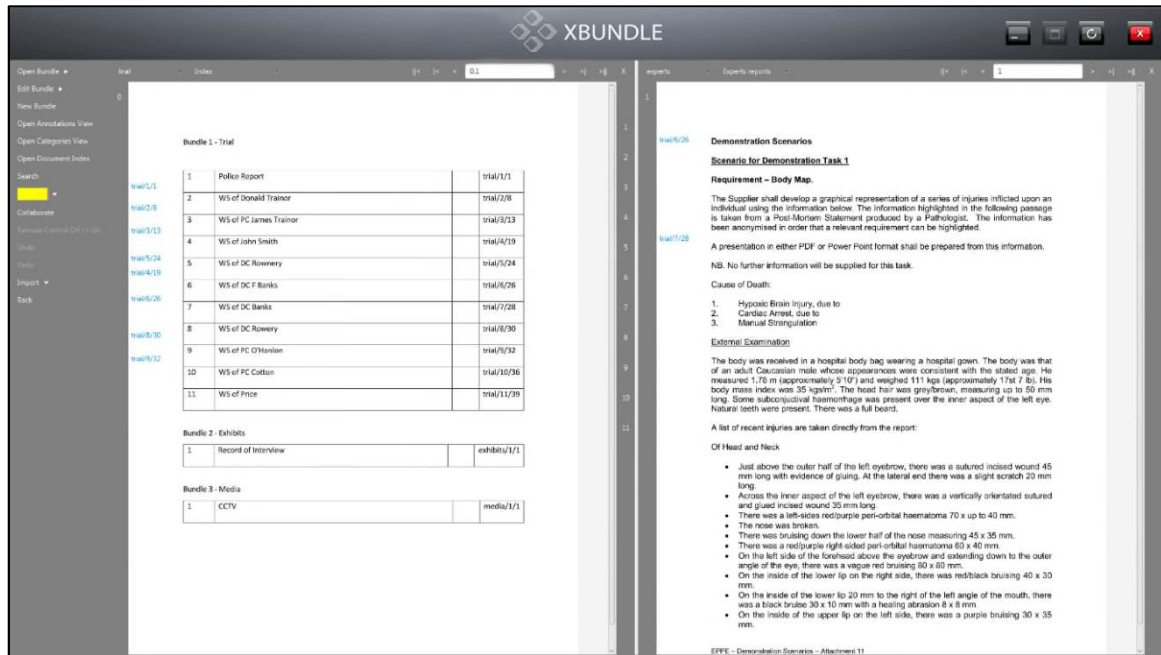

XBundle::View

We offer catered training for both end-users and service providers, covering an array of system features including (but not limited to) custom installation, import plug-in configuration and index creation.

Owned/Supplied by :	XBUNDLE
Used by :	A number of clients.

8.2.67 ZyLAB Systems

ZyLAB's eDiscovery Platform

The ZyLAB eDiscovery Platform is directly aligned with the Electronic Discovery Reference Model (EDRM) and features modules for forensically sound collection, culling, processing and legal review. ZyLAB systems are deployed in-house on-premises or in the Cloud (Azure or private cloud) and are also available in a Software-as-a-Services (SaaS) model.

ZyLAB eDiscovery platform contains the following modules:

Legal Hold

ZyLAB Legal Hold is a complete management application to create, manage and track legal holds. Users can send out legal hold notifications which can be tracked with reminders, escalations and lift notifications to ensure that legal holds are seen and enacted upon.

Collection & Processing

Automated collections and periodic recollections from many different locations and repositories into one location saving tremendous time and IT resources. Our advanced processing engine collects over 700 different file formats including complex formats such as audio and images. Data is culled, de-duplicated, enriched and prepared for legal analysis. With ZyLAB collection and processing, you can reduce the need for expensive forensic images, thus saving tremendously on the cost of specialist service providers.

Early Case Assessment

With ZyLAB, Early Case Assessment (ECA) can be performed on a data sample or in-place data sources. You can quickly assess the potential liabilities and estimate the scope of an impending legal hold and collection. It will allow you to make a full cost-benefit analysis, shape your strategy, steer settlement conferences and identify weaknesses in internal systems that need attention. ECA also allows immediate searching and data analysis for in-house efforts to settle a case on the most favourable terms.

Legal Review

The intuitive and easy-to-use Legal Review interface allows reviewers and investigators to quickly search, browse, tag, annotate and redact documents. With ZyLAB Legal Review, you can optimize the usage of in-house and outside counsel, control your external expenditures, and measure productivity. The Legal Review Dashboard highlights critical information and provides quick access and filtering of the documents.

Legal Production

Accelerates and simplifies the production of documents for opposing counsel, external counsel and regulators. Quickly produce documents by key words, bates document or metadata in different formats, including native and TIFF. Documents can be import into external case management systems for further analysis. All documents are kept in an open XML format ensuring that they can easily accessed in the future, saving you time and costs.

ZyLAB's modules

AUDIO SEARCH

ZyLAB's intuitive and cost effective Audio Search add-on utilizes high accuracy, high performance speech technology that is capable of complex searches to significantly reduce the resources required to analyse audio and video files.

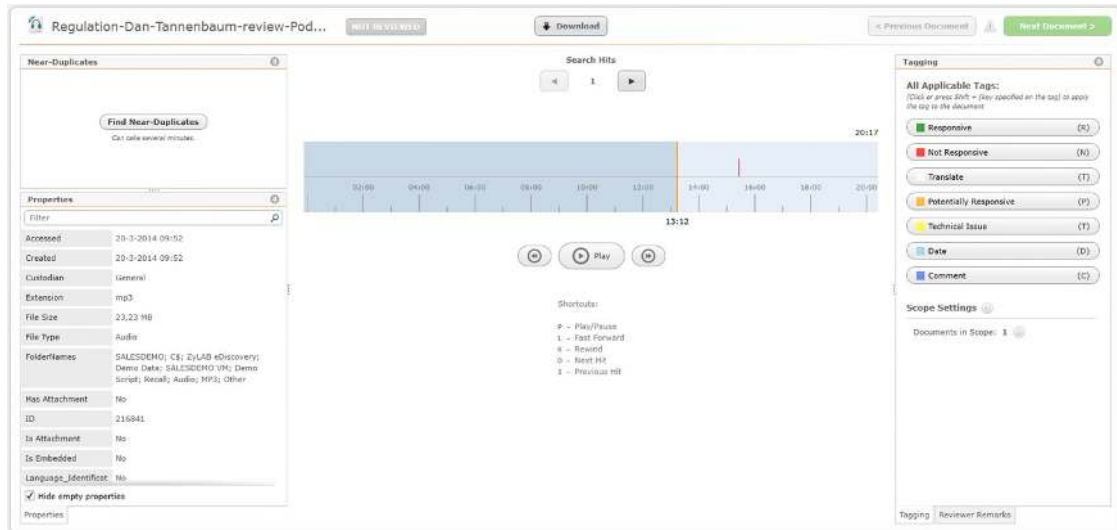

ZyLAB's Audio Search is the first eDiscovery application to incorporate audio speech search technology as part of a standard review platform to enable users to search, review and analyse audio data so that they can quickly pinpoint the relevant subset.

ZyLAB's Audio Search provides insight for legal disputes and forensic data searches with true phonetic speech technology to release valuable intelligence.

VISUAL CLASSIFICATION

The Visual Classification add-on automatically recognizes the content of pictures and videos and identifies amongst others: people, babies, elderly people, flowers, cars, planes, indoor and outdoor scenes, and many other concepts. ZyLAB's Visual Classification is aligned with the Electronic Discovery Reference Model (EDRM) and dramatically accelerates the process of searching and identifying non-textual information.

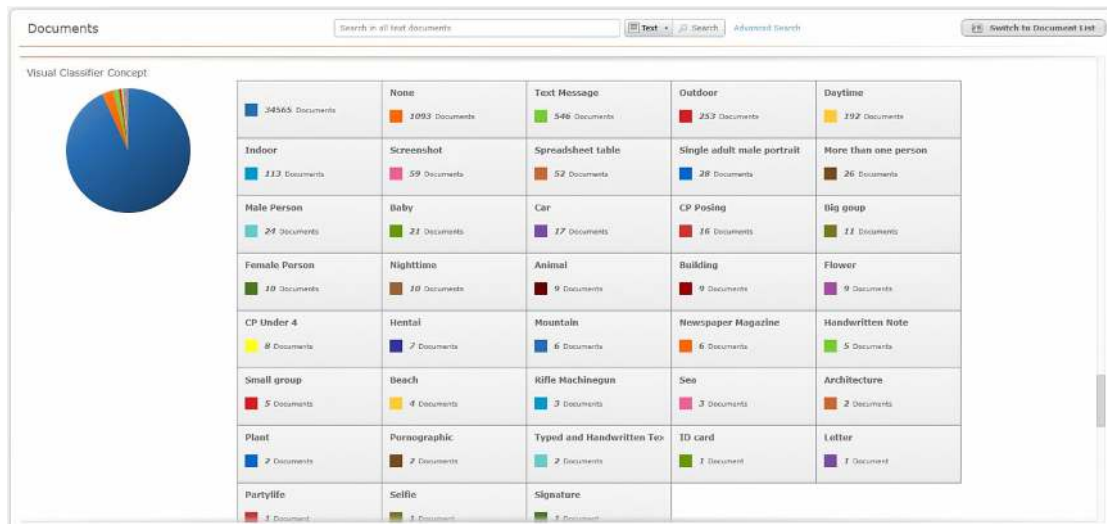

Visual classification can be used for the identification of images that contain personal identifiable information (PII), potential intellectual property (PI), handwritten notes, checks, ID's, and other information that otherwise cannot be recognized automatically and would require a full manual review. The identified objects can be tagged directly and if needed, investigated in more detail.

Chapter 8 – Supplier & Software Details

SCAN AND OPTICAL CHARACTER RECOGNITION (OCR)

ZyLAB's advanced scanning and OCR functionalities make even original signed contracts, construction blueprints, complex workflow schematics, photo's, images, bitmaps and PDF files available for search and ready for digitally archiving.

ZyLAB's scanning solution drives scanners from different brands such as Fujitsu, Canon and Kodak. The advanced OCR engines support content scanned in multiple directions (i.e., fax headers at 0, 90, 180, and 270 degrees), recognizes more than 400 foreign languages and supports voting algorithms, auto-orientation, full-color OCR and much more.

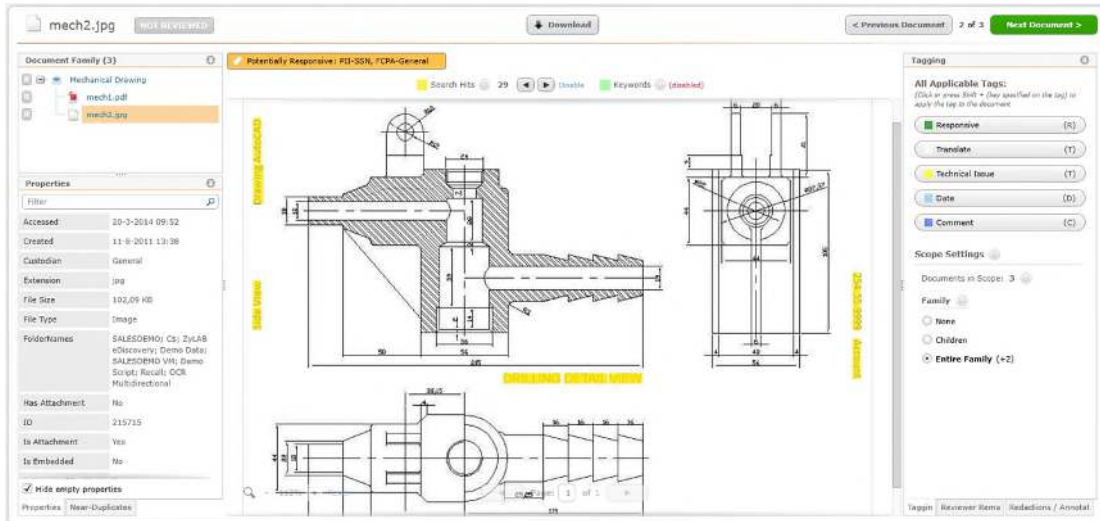

ZyLAB's Scan and OCR combines powerful functionality and 30 years of experience to increase recall and provide superb recognition results.

MACHINE TRANSLATION

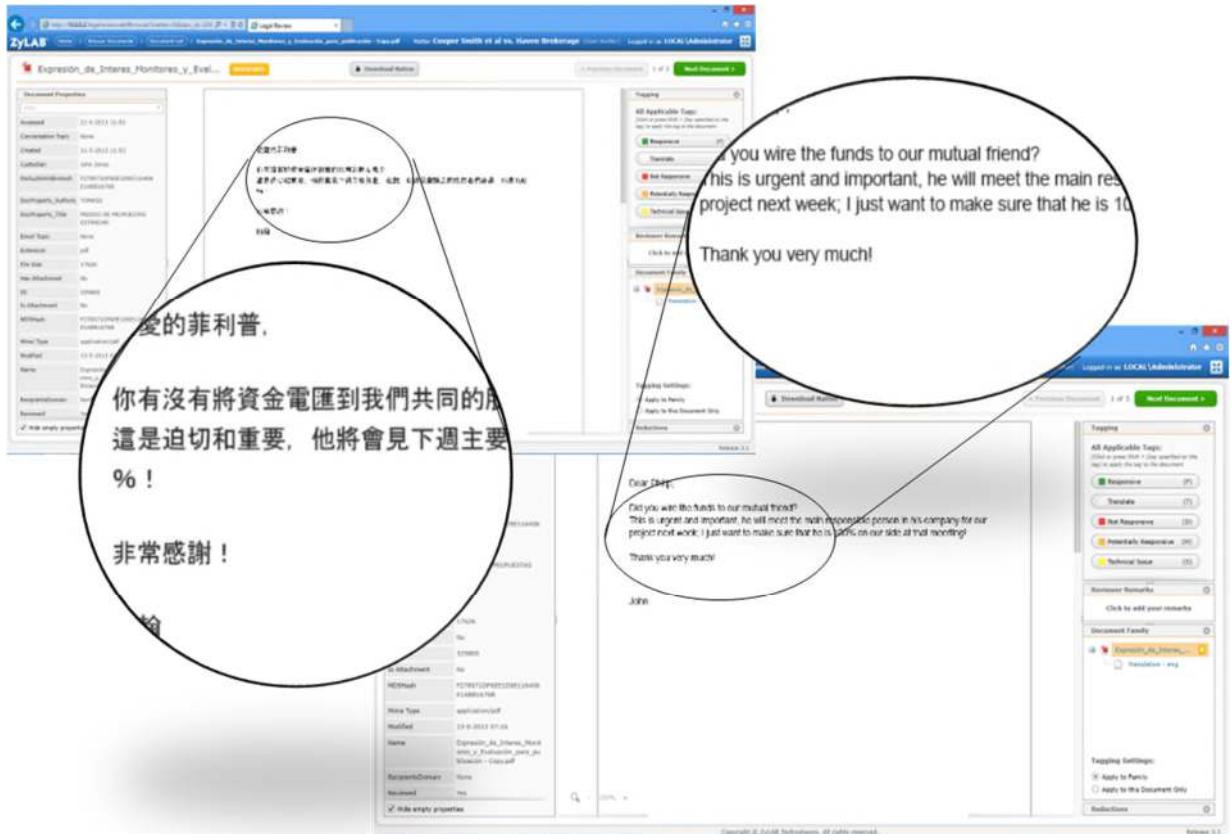

ZyLAB's Machine Translation add-on offers the unique ability to handle high volumes of translations quickly. Instead of passing on documents you can't read for review to a native speaker or translator, ZyLAB's Machine Translation option creates a fully automated translation. Translation support is offered for over 50 language pairs and can be performed during the review of the document or in batch during processing. Translations are stored as a child document to the original making sure that you can always return to the original when needed.

ZyLAB's systems leverage translation software that is based on statistics instead of complex linguistic rules. This software learns to accurately translate new information by examining previous human translations. While the translations may not be admissible in court, they do provide great insights into the content of large document and e-mail collections.

Machine translation is most relevant to intelligence, security, law enforcement, compliance, eDiscovery, and auditing work, and prevents costly and timely manual translations.

PROFESSIONAL TEXT MINING

ZyLAB's Professional Text Mining add-on leverages various mathematical, statistical, linguistic and pattern-recognition techniques to extract unknown or obscured information and knowledge from unstructured text.

By focusing on patterns and characteristics and the use of advanced techniques such as natural language processing and machine learning, text mining can produce better search results and deeper data analysis, to quickly retrieve information that otherwise would remain hidden.

ZyLAB's Professional Text Mining adds value to any circumstance in which all potentially relevant hits—as opposed to just the obvious hits—are required, such as criminal investigations, legal discovery, and due diligence investigations.

Owned/Supplied by :	ZyLAB
Used by :	ZyLAB UK Ltd.

8.2.68 Zylpha Solutions

Software Information

Electronic Document (Court) Bundling

Lawyers are great problem solvers. They are great thinkers. They do highly stressful work that is nuanced and is based in ‘the grey’ rather than the black and white world that most of us live in. Their reputation is gained and lost through the direct result of their successes and failures. All whilst dealing with ever increasing pressures from clients, the profession and even society as a whole.

Thing is, if you ask any lawyer what their main headaches are, preparing bundles will be on the list, and we find that it’s the number one administrative problem affecting lawyers today.

It’s easy to understand why, as bundles are expensive to produce. They typically contain sensitive information that you don’t want to lose, take a vast amount of time to prepare and are often produced at the last minute - making them very stressful. Bundles take hours to assemble; that’s time tied up in something that is very administrative and means you can’t work on any other case.

Put simply, it’s inefficient, expensive, time consuming and stressful.

Imagine spending half of your day photocopying, sorting documents into ring binders and handwriting page numbers. Knowing that your inbox is going unattended. That the phone won’t stop ringing. That your clients who you have worked tirelessly for aren’t getting the updates they so deservedly need because you must photocopy some documents which didn’t print properly the first time around.

On top of that you’ve been hogging the photocopier so no one else can use it. Your colleagues are having to cover the phones whilst you prepare the bundle, and you’re probably working through your lunch and staying late for those last-minute additions that never take just five minutes as everyone promises.

Simply put, it’s a time-consuming administrative task that everyone really hates doing.

We know all of this because we’ve done it ourselves. We’ve spent hours in front of the photocopier, we’ve hand typed spine labels, we’ve got the scratches and scrapes from having to use ‘that’ ring binder that doesn’t close properly.

That’s why over 12 years ago we wrote the first version of our software. To make it easy for all lawyers and legal professionals regardless of the type of work they did, or the size of the firm they worked for, to be able to produce bundles in minutes.

Owned/Supplied by :	Zylpha
Used by :	Zylpha

ANNEX A - TECHNICAL GLOSSARY

ACTIVE OR LIVE DATA: Information residing on a computer's hard drive or servers which is readily visible to users (e.g. a document, spreadsheet or an e-mail).

ALGORITHM: A detailed formula or set of steps for solving a particular problem (e.g. searching for relevant electronic documents, such as, MDS# or SHA-1#).

APPLICATION: A collection of one or more related software programmes that allow a user to enter, store, view, change or extract information from files or databases (e.g. Word, Excel and Microsoft Office). Also referred to as "programmes" or "software".

ARCHITECTURE: Hardware and/or software comprising a computer system or network.

ARCHIVAL DATA: Information that is not directly accessible to the user of a computer system but is data that the organisation maintains for long term storage and record keeping purposes (e.g. backup data).

ATTACHMENT: A record or file associated with another record for the purposes of retention or transfer. The attachment is commonly referred to as the "child" with the record it is attached to as the "parent". If the attachment itself has an attachment this would be a "grandchild" and so on. A synonym is an **ATTACHED DOCUMENT**, which means a Document attached to, or embedded in, a **HOST DOCUMENT**.

AUDIT TRAIL: Information about where data has been, in whose possession and why, held in sufficient detail so as to allow the reconstruction of that activity.

AUTHOR: The person, office or designated person responsible for a document's creation or issuance. Also referred to as "originator".

BACKUP DATA: A copy of data created as a precaution against the loss or damage of the original data. Backup data is information that is not presently in use by an organisation and is routinely stored separately upon portable media, to free up space and permit data recovery in the event of disaster. Backup data can be incremental (where only new data is saved) or complete (where all data is saved).

BACKUP TAPE RECYCLING: The process whereby an organisation's backup tapes are overwritten with new backup data, usually on a fixed schedule (e.g. the use of nightly backup tapes for each day of the week with a daily backup tape for a particular day being overwritten on the same day the following week; weekly and monthly backups being stored offsite for a specified period of time before being placed back in rotation).

BATES NUMBERING: is used in the legal, medical, and business fields to place identifying numbers and/or date/time-marks on images and documents as they are scanned or processed, for example, during the discovery stage of preparations for trial or identifying business receipts. Bates stamping can be used to mark and identify images with copyrights by putting a company name, logo and/or legal copyright on them. This process provides identification, protection, and automatic consecutive numbering of the images. The process is named after the late 19th century inventor Edwin G. Bates of New York City.

BYTE: The basic measurement of most computer data.

CD-ROM (CD READ ONLY MEMORY): Data storage medium that uses compact discs to store about 1,500 floppy discs worth of data, that is, approximately 55,000 pages. Variations include CD-Rs (CD Recordable) and CD-RWs (CD Re-Writable).

CLUSTERING: Functionality whereby ESI containing similar content is grouped together by the software without human intervention. Results might be shown in a pictorial manner with items of ESI "clustered" together, or by folders of similar documents.

COMPRESSION: The reduction of the size of a file to save storage space. "Compression ratio" is the ratio of the size of an uncompressed file to a compressed file.

COMPUTER ASSISTED REVIEW (CAR): Also known as **Technology Assisted Review (TAR)**. A process of having computer software electronically classify documents based on input from expert reviewers, in an effort to expedite the organization and prioritization of the document collection. The computer classification may include broad topics pertaining to discovery responsiveness, privilege, and other designated issues. Also see: **Predictive Coding**.

COMPUTER ASSISTED REVIEW REFERENCE MODEL (CARRM): Model used to show stages of process of Computer Assisted review (CAR).

COMPUTER FORENSICS: The use of specialised techniques for recovery, authentication, and analysis of electronic data.

CSV FILE: A computer file containing a list of values separated by a comma or other delimiter.

CUSTODIAN: Person having control of a network, computer or specific electronic folder.

DAT (DIGITAL AUDIO TAPE): A high capacity storage medium. Used in some backup systems.

DATA MAP: A written description (possibly with a diagram or two) of where the client's data sources are.

Data sampling: See Sampling.

DE-DUPLICATION: The process of identifying and removing duplicate Documents from a collection of Documents so that only one unique copy of each document remains. A cryptographic hash function such as the Message Digest algorithm 5 may be used to generate a digital fingerprint for an Electronic Document. The digital fingerprint of a Document can then be electronically compared against the digital fingerprint of any other Document to determine whether the Documents are exact duplicates. De-duplication may also be implemented by using a cryptographic hash function applied to a group of Documents.

DELETED DATA: Data that, in the past, existed on the computer as live data and which has been deleted by the computer system or end-user. Deleted data remains on storage media in whole or part until it is overwritten by on-going usage or "wiped" with a software program specifically designed to remove deleted data. Even after the data itself has been wiped, directory entries, pointers, or other metadata relating to the deleted data may remain on the computer.

DELETION: The process whereby data is removed from active files and other data storage structures on computers and rendered inaccessible except by using special data recovery tools designed to recover deleted data.

DISC (DISK): It may be a floppy disk, or it may be a hard disk. Either way, it is a magnetic storage medium on which data is digitally stored.

DISCLOSURE DATA: Data relating to disclosed Documents, including for example the type of document, the date of the document, the names of the author/sender and the recipient, and the party disclosing the document. See **OBJECTIVE** and **SUBJECTIVE CODING**. Normally only **OBJECTIVE CODING** is disclosed with documents.

DISTRIBUTED DATA: Information belonging to an organisation which resides on portable media and non-local devices such as remote offices, home computers, laptop computers, personal digital assistants (PDA's), wireless communication

devices (e.g. Blackberry) and internet repositories (such as email hosted by internet service provider or portals and web sites).

DOCUMENT: Anything in which information of any description is recorded (see CPR Rule 31.4). It includes all ESI.

DOCUMENT CODING: The process of identifying and recording case-relevant information (e.g. author, date authored, date sent, recipient, date opened, etc.) from a document. Can be automated or manual. Also referred to as **INDEXING**. See also **OBJECTIVE CODING** and **SUBJECTIVE CODING**.

DOCUMENT MANAGEMENT: The manual and automated processes for the management of documents during the course of proceedings, including the identification, preservation, collection, processing, analysis, review, production and exchange of documents.

DVD (DIGITAL VIDEO DISC OR DIGITAL VERSATILE DISC): Data storage medium, like a compact disc, upon which data can be written and read. DVDs are faster, can hold more information, and can support more data formats than **CDs**.

EARLY CASE ASSESSMENT (ECA): Also known as "**EARLY DATA ASSESSMENT**". Initial process in the EDRM approach whereby a large volume of data (normally emails and attachments) goes through various processes such as clustering, semantic analysis, and email threading to enable early decisions to be taken on the relevance of ESI.

ELECTRONIC DATA DISCLOSURE (EDD): Also known as **EDISCLOSURE**. Process of disclosing ESI. Not to be confused with using electronic means to carry out the disclosure of images of paper documents or printed out emails, Word documents etc.

ELECTRONIC DISCOVERY REFERENCE MODEL (EDRM): Model used to show stages of process of electronic discovery.

Electronic Document: see Electronically Stored Information (ESI).

ELECTRONIC IMAGE: an electronic representation of a paper document or Electronically Stored Information. An Electronic Image may be a **SEARCHABLE IMAGE** or an **UNSEARCHABLE IMAGE**. Examples are image PDF files and TIF (/TIFF) files.

ELECTRONIC STORAGE SYSTEM: A system or medium for retaining Electronically Stored Information.

ELECTRONICALLY STORED INFORMATION (ESI): Electronic files on a computer such as emails, Word, Excel, PowerPoint, Adobe PDF documents. It includes (for example) e-mail and other electronic communications such as SMS and voicemail, word-processed documents and databases, and documents stored on portable devices such as memory sticks and mobile phones. In addition to documents that are readily accessible from computer systems and other electronic devices and media, it includes documents that are stored on servers and back-up systems and electronic documents that have been 'deleted'. It also includes **METADATA** and **EMBEDDED DATA**.

EMAIL THREADING: Software functionality that pulls together the various emails that make up a "thread of conversation" and display them in an easy to understand manner. The normal aim is have the final email in a chain readily identifiable so that all the secondary emails in the conversation can be read in one pass.

EMBEDDED DATA: Text or other information which is not typically visible to the user viewing the output display on screen or as a print-out. Examples of Embedded Data include spreadsheet formulae (which display as the result of the formula operation), hidden columns, externally or internally linked files (e.g., sound files in PowerPoint presentations), references to external files and content (e.g., hyperlinks to HTML files or URLs), references and fields (e.g., the field codes for an auto-numbered document),

and certain database information if the data is part of a database (e.g. a date field in a database will display as a formatted date, but its actual value is typically a long integer).

ENCRYPTION: Procedure whereby the contents of a message or file are scrambled or made unintelligible to anyone not authorised to use it.

FIELD: A section of data in a database, for example a field containing the date of a document.

FILE SLACK SPACE: A form of residual data, slack space is the amount of on-disk file space from the end of their logical record information to the end of the physical disk record. Slack space can contain information soft-deleted from the record, information from prior records stored at the same physical location as current records, metadata fragments and other information useful for forensic analysis of computer systems.

FORENSIC COPY: An extract copy of an entire physical storage medium (hard drive, CD-ROM, DVD, tape etc.). Also referred to as "mirror imaged copies", "imaging" and "disc mirroring".

FORMAT: The way in which Electronic Images and other documents are stored and made accessible.

GIF (GRAPHIC INTERCHANGE FORMAT): A computer compression format for pictures.

GIGABYTE (GB): A measure of computer data storage capacity and equivalent to a billion (1,000,000,000) bytes. Also referred to as a "gig".

HARD DRIVE: The primary storage unit on PCs, consisting of one or more magnetic media platters on which digital data can be written and erased magnetically.

HOST DOCUMENT: A Document with one or more ATTACHED DOCUMENTS. For example, an e-mail is a Host Document and any Documents attached to the e-mail are its Attached Documents.

Indexing: See Document Coding.

INTERNET SERVICE PROVIDER (ISP): A business that provides access to the Internet.

JPEG (JOINT PHOTOGRAPHIC EXPERTS GROUP): An image compression standard for photographs.

KEYWORD SEARCH: A search for documents containing one or more words that are specified by a user. Normally conducted on **ELECTRONICALLY STORED INFORMATION**, but can also be carried out on **OCR TEXT**.

KILOBYTE (KB): A measure of computer data storage capacity and equivalent to a thousand (1,000) bytes.

LEGACY DATA: Information that has been created or stored by the use of software and/or hardware that has become obsolete or has been replaced ("Legacy Systems").

LEGACY SYSTEMS: Systems containing legacy data.

LITIGATION HOLD: An instruction issued as a result of current or anticipated litigation, audit investigation or other such matter that suspends the normal processing or disposal of records.

LITIGATION SUPPORT SOFTWARE/SYSTEM: Application that supports the process of litigation. In terms of the EDRM approach this stage occurs after the Early Case Assessment stage.

LOOSE DOCUMENT: An Electronic Document that is stored in its Native Form in a file system or directory system but not an email box. An email or document attached to an email, even if extracted from the email box in which it was originally stored, is not a

Loose Document.

MEDIA FREE SPACE: Unused space on storage media that is available for storage.

MEGABYTE (MB): A measure of computer data storage capacity and equivalent to a million (1,000,000) bytes. Also referred to as a "meg".

METADATA: Commonly described as "data about data". It is information that may describe, for example, how, when and by whom it was received, created, accessed, modified and how it is formatted. Some metadata, such as file date and sizes, can easily be seen by users. Other metadata can be hidden or embedded and is unavailable to computer users who are not technically adept. Metadata is generally not reproduced in full form when a document is printed.

MIGRATED DATA: Information that has been moved from one database or format to another.

MIRROR IMAGE: Used in computer forensic investigations and some electronic disclosure investigations, a mirror image is an exact bit-by-bit copy of a computer hard drive that ensures the operating system is not altered during the forensic examination. May also be referred to as "disc mirroring", or as a "forensic copy" or "imaged copy".

MPEG (MOVING PICTURES EXPERT GROUP): An image compression standard for full motion video.

NATIVE FORMAT: An associated file structure for an electronic document defined by the original creating application. Viewing or searching documents in the native format may require the original application (for example, viewing a Microsoft Word document may require the Microsoft Word application).

NETWORK: A group of one or more computers and other devices connected together for the exchange and sharing of data and resources.

OBJECTIVE CODING: Coded information that can be derived from a document without any specific legal training. Normally comprises; Date, Estimated Date, Document Title, Document Type, From, To, Copyee. Objective coding is normally conducted by a vendor (often overseas to provide a cheaper service).

OFF-LINE DATA: The storage of electronic data outside the network in daily use that is only accessible through the off-line storage system.

Optical Character Recognition ('OCR'): means the computer-facilitated recognition of printed or written text characters in an Unsearchable Image

OFF-LINE DATA: The storage of electronic data outside the network in daily use that is only accessible through the off-line storage system.

ON LINE DATA: Electronic data stored on the network in daily use.

PDF (PORTABLE DOCUMENT FORMAT): A common format for images of documents which enables documents to be displayed or printed a manner which preserves the formatting originally used by the author. A PDF file may be either a Searchable Image file or an Unsearchable Image file.

PETABYTE (PB): A petabyte is a measure of computer data storage capacity and equivalent to one quadrillion (1,000,000,000,000,000) bytes.

PERSONAL DATA: Information of a personal nature that must not be disclosed, such as medical records, salary, home addresses, relationship discussions, social security numbers, etc. Personal data is normally **REDACTED**.

PREDICTIVE CODING: Functionality that automatically codes records by conducting analysis on the ESI. The coding can encompass **OBJECTIVE** and **SUBJECTIVE CODING**.

Objective coding is usually a simpler process than the Subjective work which requires the software to be "seeded" with examples of relevant and/or Privilege documents. The application then "learns" what criteria it uses to arrive at the Subjective decisions and (once trained) will identify those documents and pass them to a user for confirmation on the coding calls. See also: **COMPUTER ASSISTED REVIEW REFERENCE MODEL (CARRM)**.

PST (PERSONAL STORE): The place where Microsoft Outlook stores its data (when Outlook is used without Microsoft Exchange Server). A PST file is created when a mail account is set up. Additional PST files can be created for backing up and archiving Outlook folders, messages, forms and files. The file extension given to PST files is .pst. Can be broken down into individual emails called .msg.

RETENTION PERIOD: The length of time a given records series must be kept, expressed as either a time period (e.g. four years), an event or action (e.g. audit), or a combination (e.g. six months after audit).

REDACTION: The process whereby sensitive information is hidden by rendering part of a document unreadable. It is sometimes referred to as 'Masking'. Redaction is typically used to render unreadable; confidential, privileged or personal data portions of an otherwise disclosable document.

RESIDUAL DATA: Data that is not active on a computer system (sometimes referred to as "Ambient Data"). Residual data includes (1) data found on media free space; (2) data found in file slack space; and (3) data within files that has functionally been deleted, in that it is not visible using the application with which the file was created, without use of undelete or special data recovery techniques.

RESTORE: To transfer data from a backup medium (such as tapes) to an on-line system, often for the purposes of recovery from a problem, failure, or disaster. Restoration of archival media is the transfer of data from an archival store to an on-line system for the purposes of processing (such as query, analysis, extraction or disposition of that data). Archival restoration of systems may require not only data restoration but also replication of the original hardware and software operating environment. Restoration of systems is often called "recovery".

SAMPLING: Usually (but not always) refers to the process of statistically testing a data set for the likelihood of relevant information. It can be a useful technique in addressing a number of issues relating to litigation, including decisions as to which repositories of data should be preserved and reviewed, and determinations of the validity and effectiveness of searches or other data extraction procedures. Sampling can be useful in providing information to the court about the relative cost burden versus benefit of requiring a party to review certain electronic records.

SEARCHABLE IMAGE: An ELECTRONIC IMAGE in which the text-based contents can be searched electronically.

SEMANTIC ANALYSIS : Method by which a number of products conduct clustering. Refers to the "automatic" identification of key words and concepts within a document so that there is a "spine" of a central concept, off which related groups of documents are clustered.

SCANNING: The process of converting a hard copy paper document into a digital image for use in a computer system. Often associated with the **OCR** process, as in "documents will be scanned and subject to an OCR process".

SUBJECTIVE CODING: Information held in a litigation support system about records (either paper or electronic). Subjective coding requires legal input and covers initial calls on Relevance, Privilege and Trade Secret as well as case specific issue and matter coding.

TECHNOLOGY ASSISTED REVIEW (TAR): See: **Computer Assisted Review (CAR)** and **Predictive Coding**.

TERABYTE (TB): A measure of computer data storage capacity and equivalent to one trillion (1,000,000,000,000) bytes.

TIF OR TIFF (TAGGED IMAGE FILE FORMAT): One of the most widely supported file formats for storing bit-mapped images. Files in TIFF format often end with a .tiff extension. Other file formats include JPG and BMP.

Unattached Document: An Electronic Document without a Host Document.

UNSEARCHABLE IMAGE: An Electronic Image in which the text-based contents cannot be searched electronically.

ANNEX B – BLANK VENDOR FORM

The following form was distributed to all the vendors shown in the Guide. Should any organisation wish to be entered into future versions, please complete the document and submit it. There is no charge for inclusion in the Guide.

Vendor Information

Vendor Name	Logo here
Contact (name), phone number, email.	
Address as a single line.	
Company Website.	
<u>Company Description</u>	
<p>Synoptic paragraph (or two) on the history of the company and its background, You might want to provide details on:</p> <ul style="list-style-type: none"> • When the company was founded, and its history. • Size (both in personnel and financials) in the UK and overall. • Focus of the organisation. • Any particular individuals / specialisations you are known for. <p>But basically it's up to you. We will be trying to keep the Vendor pages to a relatively uniform size so reserve the right to trim your 14 page opus down to a few paragraphs.</p>	
<u>Vendor Offerings</u>	
<p>What services and software you provide. Mention software by name only, there is a separate section to describe it in detail. Don't want price lists or short term offers, this information will be in the document for at least a year. Don't just mention the software, explain (briefly) what you do with it in terms the layman can understand.</p>	
<u>Sign off from organisation</u>	
<p>Who in the organisation is providing the information and should be contacted over any issues. Will also be the person responsible for all text and factual content.</p>	

Software Information

Some software is owned and only provided by certain vendors, but other applications are used by a number of people, so we are splitting out the software into a separate section.

Again, please only about a page of information on each bit of software and what it does, less is good, but make sure you give enough detail so that users of the Guide can compare like with like. We reserve the right to take competing descriptions of the same application and use the one that seems to suits our needs best, but will show in the Guide all the vendors that supply that software.